

Preliminary version for reviews dated December 1, 2010

NEW SCIENCES FOR A NEW ERA



Professor R. M. Santilli in 2008 (photo of Club Med in Martinique)

Mathematical, Physical and Chemical Discoveries of Ruggero Maria Santilli

Ivan Gandzha and Jerdsey Kadisvily

The Institute for Basic Research

Palrn Harbor, Florida, USA

Sankata Printing Press, Nepal.

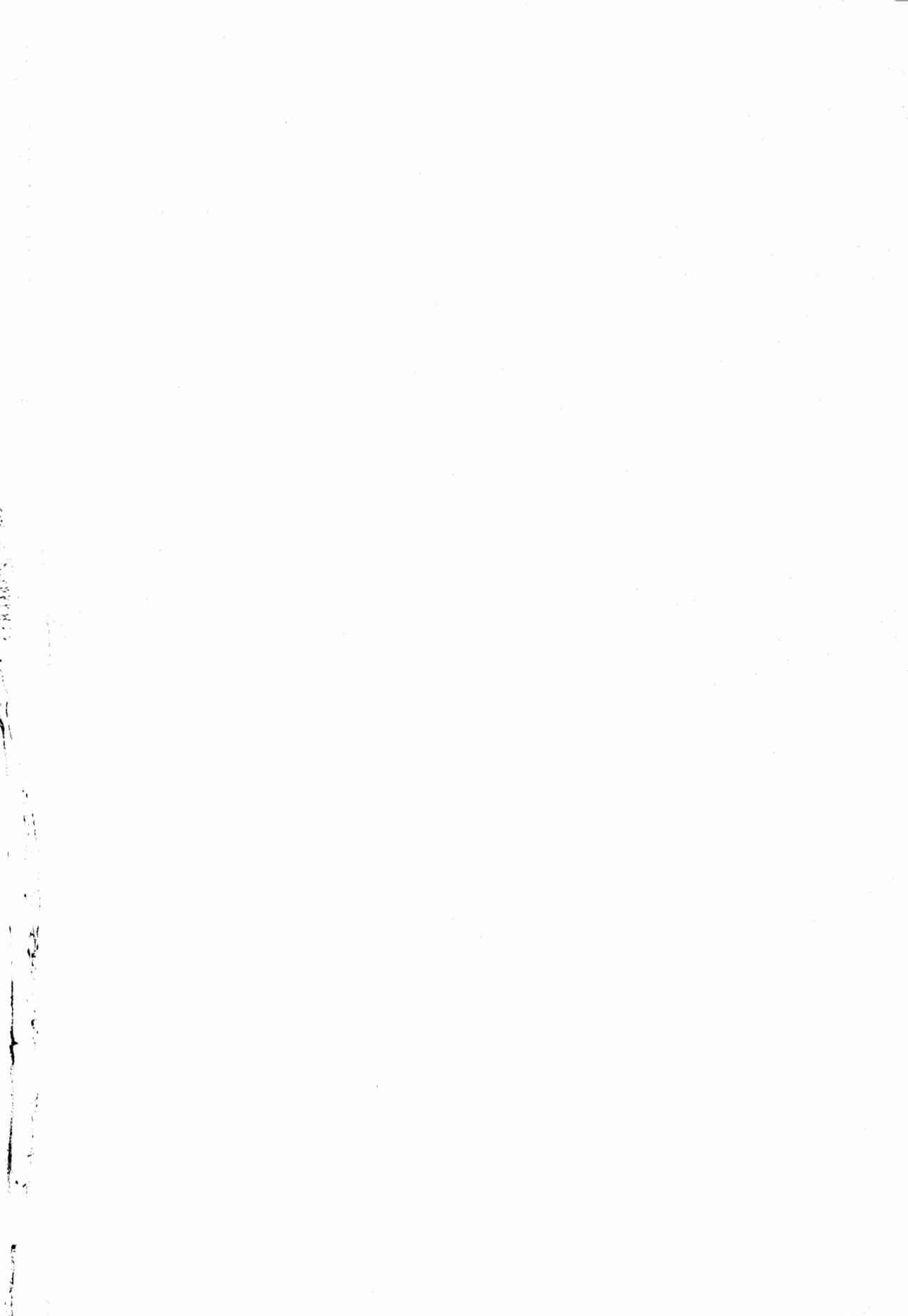

Preliminary version for reviews dated December 1, 2010

NEW SCIENCES FOR A NEW ERA
Mathematical, Physical and Chemical Discoveries of
Ruggero Maria Santilli

Ivan Gandzha and Jerdsey Kadeisvily
The Institute for Basic Research
Palm Harbor, Florida, U.S.A.

© 2010 by *The R. M. Santilli Foundation*
150 Rainville Rd, Tarpon Springs, FL 34689, U.S.A.
board@santilli-foundation.org, www.santilli-foundation.org

Copyright Notice

To the best knowledge of the Board of Directors of the R. M. Santilli Foundation (the “Foundation” hereon), the free download of all pdf files available in this book is in compliance with current Copyright Laws, the Millennium Electronic Act, and other international agreements due to prior copyright filing.

Santilli recorded over the years at the U. S. Library of Congress the Copyright of all its most important works for protection against widespread plagiarisms and paternity frauds. The Foundation has secured a notarized agreement with Santilli for the free download of all such Copyrighted works. Additional agreements have been secured by Santilli and/or the Foundation with Hadronic Press, Inc., International Academic Press, Kluwer Academic Publisher, Naukova Dumka, and other publishers whose books have been made available in free download in the References of this volume. Similar written authorizations have been secured for the work of other authors. Inactive links indicate that the Copyright authorization is currently missing, under way or under negotiation.

In the event of possible errors due to the number of publications herein made available to the scientific community at no charge, the Foundation requests a prompt notification for immediate corrections at the email “board(at)santilli-foundation(dot)org”.

Scientists are hereby authorized to print, copy and use any copyrighted publications listed in this volume under the sole condition of properly quoting them in the proper chronological order. Paternity frauds will be prosecuted. All direct or indirect responsibilities on copyright matters solely belong to the R. M. Santilli Foundation.

Richard Anderson

Trustee

The R. M. Santilli Foundation

<http://www.santilli-foundation.org/>

Printed at:

Sankata Printing Press

Kathmandu, Nepal. Tel: 4231115

Contents

Contents	iii
Preface	xiii
1. INSUFFICIENCIES OF THE 20-TH CENTURY THEORIES	1
1.1 The Legacy of Lagrange and Hamilton	1
1.2 Insufficiencies of Galilei and Special Relativity	5
1.3 Insufficiencies of General Relativity	8
1.4 Insufficiencies of Einstein's Theories for Antimatter	9
1.5 Insufficiencies of Quantum Mechanics	9
1.6 Insufficiencies of Nuclear Physics	12
1.7 Insufficiencies of Particle Physics	14
1.8 Insufficiencies of Quarks and Neutrinos Conjectures	16
1.9 Insufficiencies of Quantum Chemistry	19
1.10 Insufficiencies of Biology	21
1.11 Insufficiencies of Astrophysics and Cosmology	22
1.12 Introductory Readings	23
2. SANTILLI'S DISCOVERIES IN MATHEMATICS	25
2.1 Foreword	25
2.2 Discovery of New Numbers	28
2.2.A Discovery of isonumbers (1983)	28
2.2.B Discovery of genonumbers (1993)	30
2.2.C Discovery of hypernumbers (1994)	31
2.2.D Discovery of isodual numbers (1993)	32
2.3 Discovery of Iso-, Geno-, Hyper-Differential Calculi, Functional Analysis and Their Isoduals (1996)	34
2.4 Discovery of Iso-, Geno-, Hyper-, Spaces and Their Isoduals (1983)	36
2.4.A Santilli's generalized spaces	36
2.4.B Preliminary implications	37
2.4.C Iso-, geno-, hyper-topologies and their isoduals	39
2.5 Discovery of Iso-, Geno-, Hyper-Symplectic Geometries and Their Isoduals (1996)	41

2.6	Isotopic Unification of Minkowskian, Riemannian, and other Geometries (1998)	42
2.7	Lie-Isotopic Covering of Lie's Theory and Its Isodual (1978)	43
2.8	Lie-Admissible Covering of the Lie-Isotopic Theory And Its Isodual (1967)	47
	2.8.A The birth of Lie-admissibility	47
	2.8.B Santilli Lie-admissible theory	49
	2.8.C Santilli-Vougiouklis multi-valued hyper-Lie theory	53
2.9	Integrability Conditions for the Existence of a Lagrangian	54
	2.9.A Integrability conditions in Newtonian mechanics (1978)	54
	2.9.B Integrability conditions in field theory (1975)	55
3.	SANTILLI'S DISCOVERIES IN THEORETICAL PHYSICS	57
3.1	Foreword	57
3.2	Ether As a Universal Substratum (1952–1955)	57
3.3	Origin of the Electric and Magnetic Fields (1955–1957)	61
3.4	Origin of the Gravitational Field (1974)	64
3.5	Symmetry of the Ether (1970)	67
3.6	QFT (And QCD) Violations from Discrete Symmetry Violations (1974)	69
3.7	Resolution of the Historical Imbalance on Antimatter (1994)	72
	3.7.A Apparent lack of visibility of antimatter asteroids with Sun light	72
	3.7.B Newton-Santilli isodual equation for antimatter	73
	3.7.C Isodual Representation of the Coulomb Force	75
	3.7.D Hamilton-Santilli isodual mechanics	76
	3.7.E Isodual special and general relativities	76
	3.7.F Prediction of antigravity	76
	3.7.G Test of antigravity	77
	3.7.H Isodual quantum mechanics	77
	3.7.I Experimental detection of antimatter galaxies	79
	3.7.J The new isoselfdual invariance of Dirac's equation	79
	3.7.K Dunning-Davies thermodynamics for antimatter	81
	3.7.L Isoselfdual spacetime machine	81
	3.7.M Original literature	81
3.8	Initiation of q -Deformations of Lie Theory	81
3.9	Theorems of Catastrophic Inconsistencies of Noncanonical and Nonunitary Theories	83

3.9.A	The majestic consistency of Hamiltonian theories	83
3.9.B	Theorems of catastrophic inconsistencies of noncanonical and nonunitary theories	85
3.9.C	Examples of catastrophically inconsistent theories	86
3.9.D	Original literature	87
3.10	Santilli Relativities (1978)	87
3.10.A	Approximate character of Galilei and special relativity within physical media	87
3.10.B	Santilli's opening statement	90
3.10.C	Conceptual foundations	91
3.10.D	Mathematical foundations	93
3.10.E	Invariance and universality of Santilli's isotopies	94
3.10.F	Lorentz-Poincaré-Santilli isosymmetry and its isodual	96
3.10.G	Santilli isorelativity and its isodual	98
3.10.H	Santilli's isogravitation and its isodual	100
3.10.I	Santilli's geno- and hyper-relativities and their isoduals	103
3.10.J	Isotopic reconstruction of exact spacetime symmetries when conventionally broken	103
3.10.K	Experimental verifications	104
3.10.L	Original literature	107
3.11	Hadronic Mechanics (1967)	108
3.11.A	Foreword	108
3.11.B	Historical notes	110
3.11.C	Interior and exterior dynamical systems	119
3.11.D	Closed and open dynamical systems	121
3.11.E	Newton-Santilli isoequations	123
3.11.F	Hamilton-Santilli isomechanics	125
3.11.G	Animalu-Santilli isoquantization	127
3.11.H	Hilbert-Santilli isospaces	128
3.11.I	Schrödinger-Santilli isoequations	129
3.11.J	Heisenberg-Santilli isoequations	130
3.11.K	Dirac-Myung-Santilli isodelta function and elimination of quantum divergencies	130
3.11.L	Genotopic and hyperstructural branches of hadronic mechanics	132
3.11.M	Isodual branches of hadronic mechanics	133
3.11.N	Two-body hadronic system	134
3.11.O	Simple construction of hadronic mechanics	135
3.11.P	Invariance of hadronic mechanics	137

7.3.K	Engineering conception of hadronic reactors	444
7.3.L	Experimental verification of nitrogen synthesis without harmful radiations or waste	449
7.3.L.A	Experimental set up	449
7.3.L.B	Conduction of the tests	451
7.3.L.C	Experimental results	451
7.3.L.D	Tests with deuterium and tungsten electrodes	454
7.3.L.E	Tests with air and tungsten electrodes	455
7.3.L.F	Tests with hydrogen and carbon electrodes	455
7.3.L.G	Tests with magnegas and carbon electrodes	457
7.3.L.H	Experimental confirmation of Santilli magnecules	458
7.3.L.I	Dismissal of hydrogen as hadronic fuel	462
7.3.M	Independent verification of Santilli's nitrogen synthesis without harmful radiation or waste	464
7.3.M.A	Foreword	464
7.3.M.B	Deuterium-carbon fusion	464
7.3.M.C	Gas spectra analysis	465
7.3.M.D	Elemental microanalysis	465
7.3.M.E	Thermal analysis	467
7.3.M.F	Radiation Analysis	470
7.3.M.G	Conclusions	470
7.4	New Hadronic Energies of Particle Type	472
7.4.A	Introduction	472
7.4.B	The stimulated decay of the neutron	473
7.4.C	Neutron stimulated decay via photons with resonating frequency	474
7.4.D	Hadronic energy of particle type	476
7.4.E	Hadronic energies via double beta decays	476
7.4.F	Tsagas experiment on the Stimulated Neutron Decay	479
7.4.G	Recycling of radioactive nuclear waste via their stimulated decay	480
7.5	Epilogue	483
	Bibliography	484
	Index	505

4.5.C	Representation of biological structures via Santilli's deformable, irreversible and multi-valued hypermathematics	210
4.5.D	Hypermolecules, hypermagnecules and hyperliquids	215
4.5.E	Deciphering the DNA code?	216
4.5.F	Understanding the DNA structure?	217
4.5.G	A future new cure for cancer?	218
4.5.H	Cloonan's advances in Santilli Magnecules	219
5.	EXPERIMENTAL VERIFICATIONS IN CLASSICAL PHYSICS, PARTICLE PHYSICS, NUCLEAR PHYSICS, CHEMISTRY, SUPERCONDUCTIVITY, ASTROPHYSICS, ANTIMATTER AND COSMOLOGY	223
5.1	Introduction	223
5.1.A	The unreassuring conditions of 20th century particle physics	223
5.1.B	Mutation of particles in interior conditions	225
5.1.C	Mutation of spacetime caused by physical media	227
5.2	Experimental Verifications in Classical and Particle Physics	228
5.2.A	Experimental verification of the mutation of magnetic moments	228
5.2.B	Experimental verification with the meanlives of unstable hadrons	236
5.2.C	Experimental verifications with arbitrary local causal speeds	244
5.2.D	Experimental verification via the Bose-Einstein correlation	246
5.2.E	Characterization of hadronic media	252
5.3	Experimental Verifications in Nuclear Physics	254
5.3.A	The unreassuring condition of 20th century nuclear physics	254
5.3.B	Experimental verification with nuclear magnetic moments	259
5.3.C	Experimental verifications with the nuclear force	262
5.4	Experimental Verifications in Chemistry and Superconductivity	262
5.4.A	Experimental verifications in chemistry	262
5.4.B	The unreassuring condition of 20th century superconductivity	263
5.4.C	Animalu's isosuperconductivity	264
5.4.D	Experimental verification of Animalu's isosuperconductivity	267

5.4.E	Initial basic laws of hadronic mechanics	269
5.5	Experimental Verification with the Behavior of Light	272
5.5.A	The inevitability of the ether as a universal medium	272
5.5.B	Experimental verification with light propagating in water	274
5.5.C	Santilli isoredshift	276
5.5.D	Experimental confirmation of Santilli's isoredshift	278
5.5.E	Experimental verification with the colors our atmosphere	280
5.6	Experimental Verifications in Astrophysics	284
5.6.A	The unreassuring condition of 20th century astrophysics	284
5.6.B	Absence of universe expansion	286
5.6.C	Absence of "dark matter"	288
5.6.D	Absence of "dark energy"	290
5.6.E	Experimental verification with quasar redshifts	292
5.7	Experimental Verification with Antimatter and Cosmology	295
5.7.A	The unreassuring condition of 20th century antimatter and cosmology	295
5.7.B	Experimental verification of Santilli's isodual theory of antimatter	297
5.7.C	Santilli's isoselfdual cosmologies	297
	Appendices	302
5.A	Newton-Santilli Universal Gravitation	302
5.B	Lie-isotopic and Lie-admissible scattering theories	305
6.	REDUCTION OF MATTER TO PROTONS AND ELECTRONS	307
6.1	Introduction	307
6.1.A	Foreword	307
6.1.B	Santilli's recollections on the birth of hadronic mechanics	310
6.1.C	New structure model of unstable hadrons and leptons	313
6.1.D	Inapplicability of quantum mechanics to the structure of hadrons	316
6.1.E	The dichotomy: classification vs structure of hadrons and leptons	318
6.2	Reduction of Mesons and Leptons to Electrons and Positrons	320
6.2.A	Conception of the π^0 structure	320
6.2.B	Structure equation of the π^0	322
6.2.C	Solution of the π^0 structure equation	327
6.2.D	Structure model of unstable leptons and of the remaining mesons	332
6.2.E	Revisions due to the isodual theory of antimatter	339

6.2.F	Compatibility of the new structure model of hadrons with unitary classifications	340
6.2.G	Experimental verifications	341
6.3	Reduction of Baryons to Protons and Electrons	342
6.3.A	Conception of the neutron structure	342
6.3.B	Nonrelativistic exact and invariant representation of the neutron rest energy, meanlife and charge radius	343
6.3.C	Nonrelativistic, exact and invariant representation of the neutron spin	347
6.3.D	Nonrelativistic, exact and invariant representation of the neutron magnetic moment	350
6.3.E	Foundations of the relativistic treatment	351
6.3.F	Relativistic, exact and invariant representation of the neutron rest energy, meanlife and charge radius	353
6.3.G	Relativistic, exact and invariant representation of the neutron spin	355
6.3.H	Relativistic, exact and invariant representation of the anomalous magnetic moment of the neutron	355
6.3.I	Santilli's etherino vs Fermi's neutrino	356
6.3.J	Structure model of the remaining baryons with physical constituents	366
6.3.K	Compatibility of baryon syntheses with the SU(3) classification	367
6.4	Laboratory Synthesis of Neutrons from a Hydrogen Gas	367
6.4.A	Introduction	367
6.4.B	Don Borghi experiment on the synthesis of neutrons from a hydrogen gas	370
6.4.C	Santilli experiment on the synthesis of neutrons from a hydrogen gas	371
6.4.D	The Don Borghi-Santilli neutroids	377
6.4.E	Interpretation of Don Borghi and Santilli experiments	380
6.4.F	Santilli's prediction of a new class of nuclides	381
6.4.G	Requirements for the re-run of Santilli's experiments	383
6.5	Reduction of Nuclei to Protons and Electrons	384
6.5.A	Introduction	384
6.5.B	Santilli's contributions in nuclear physics	386
6.5.C	Review of basic nuclear contributions	386
6.5.D	Review of Lie-isotopic nuclear contributions	391
6.5.E	Review of Lie-admissible nuclear contributions	394
6.5.F	Reduction of the deuteron to two protons and one electron	396

6.5.F.A	Foreword	396
6.5.F.B	Insufficiencies of quantum mechanics for the deuteron structure	396
6.5.F.C	Conception of the deuteron structure	400
6.5.F.D	Representation of the stability of the deuteron	401
6.5.F.E	Representation of the deuteron size	401
6.5.F.F	Representation of the deuteron charge	403
6.5.F.G	Representation of the deuteron spin	403
6.5.F.H	Representation of the deuteron magnetic moment	405
6.5.F.I	Representation of the deuteron force	406
6.5.F.J	Representation of the deuteron total energy	407
6.5.F.K	Representation of the deuteron electric dipole moment and parity	409
6.5.G	Reduction of matter to proton and electrons	410
6.5.H	Reduction of neutron stars to protons and electrons	410
7.	NEW CLEAN ENERGIES FOR A NEW ERA	411
7.1	Introduction	411
7.2	New hadronic energies of atomic type	413
7.2.A	Limitations of 20th century doctrines for energy releasing processes	413
7.2.B	Conventional molecular combustion	415
7.2.C	Santilli's magnecular combustion	416
7.3	New hadronic energies of nuclear type	420
7.3.A	Foreword	420
7.3.B	Insufficiencies of "cold" and "hot" fusions	420
7.3.C	Santilli's main idea for new controlled fusions	422
7.3.D	Insufficiencies of quantum mechanics, quantum chemistry and special relativity for controlled fusions	423
7.3.E	Insufficiencies of quark and neutrino conjectures for controlled nuclear fusions	424
7.3.F	Basic assumptions of intermediate controlled nuclear fusions	425
7.3.G	Physical laws of controlled nuclear fusions	428
7.3.H	The role of Santilli magnecules for controlled nuclear fusions	431
7.3.I	Engineering conception and realization of hadronic refineries	432
7.3.J	The physics of intermediate controlled nuclear fusions	438

7.3.K	Engineering conception of hadronic reactors	444
7.3.L	Experimental verification of nitrogen synthesis without harmful radiations or waste	449
7.3.L.A	Experimental set up	449
7.3.L.B	Conduction of the tests	451
7.3.L.C	Experimental results	451
7.3.L.D	Tests with deuterium and tungsten electrodes	454
7.3.L.E	Tests with air and tungsten electrodes	455
7.3.L.F	Tests with hydrogen and carbon electrodes	455
7.3.L.G	Tests with magnegas and carbon electrodes	457
7.3.L.H	Experimental confirmation of Santilli magnecules	458
7.3.L.I	Dismissal of hydrogen as hadronic fuel	462
7.3.M	Independent verification of Santilli's nitrogen synthesis without harmful radiation or waste	464
7.3.M.A	Foreword	464
7.3.M.B	Deuterium-carbon fusion	464
7.3.M.C	Gas spectra analysis	465
7.3.M.D	Elemental microanalysis	465
7.3.M.E	Thermal analysis	467
7.3.M.F	Radiation Analysis	470
7.3.M.G	Conclusions	470
7.4	New Hadronic Energies of Particle Type	472
7.4.A	Introduction	472
7.4.B	The stimulated decay of the neutron	473
7.4.C	Neutron stimulated decay via photons with resonating frequency	474
7.4.D	Hadronic energy of particle type	476
7.4.E	Hadronic energies via double beta decays	476
7.4.F	Tsagas experiment on the Stimulated Neutron Decay	479
7.4.G	Recycling of radioactive nuclear waste via their stimulated decay	480
7.5	Epilogue	483
	Bibliography	484
	Index	505

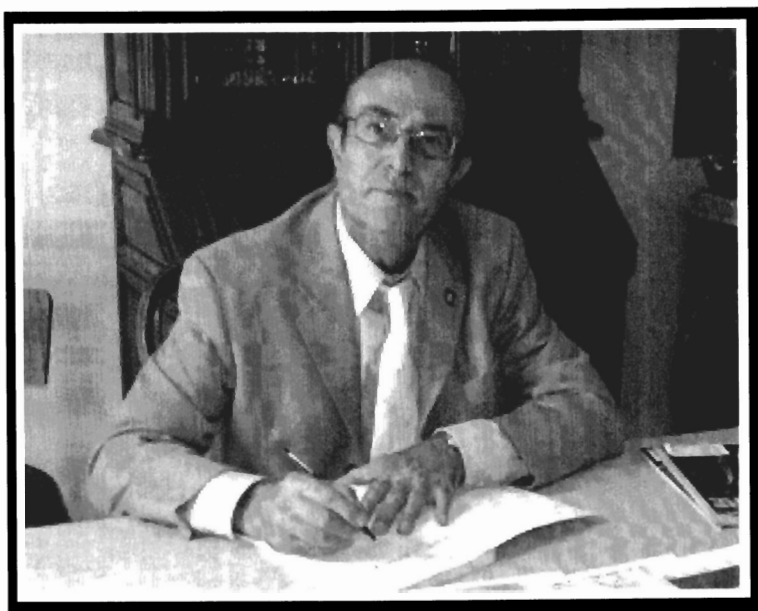

A view of Prof. Ruggero Maria Santilli at age 73 taken in June 2008 by the Italian magazine *QuattroRuote* (reproduced under copyright authorization).

PREFACE

By using a language accessible to the general scientific audience, this volume presents an outline of the discoveries by the Italian-American scientist Ruggero Maria Santilli (“Santilli” hereon, see Ref. [207] for the CV) in mathematics, physics and chemistry with particular reference to their primary intended scope:

The conception, quantitative treatment, test and industrial realization of new, clean energies and fuels so much needed by mankind that are inconceivable with the mathematics, physics and chemistry of the 20-th century.

In the references, we make available all quoted literature in free pdf downloads since the original papers and books are at times of difficult location, having been published in refereed journals the world over.

Santilli’s discoveries have been the subject of a large number of contributions by scientists from numerous countries which we regret not to be able to review in this volume to prevent a prohibitive length. For contributions by other authors, interested scholars may consult the 50 pages long *General Bibliography* available at the end of Ref. [20]).

Interested researchers or historians are suggested to exercise caution in using preprints of various works that are still circulating in the scientific community, because Santilli has the habit of quickly writing papers, sending them to colleagues for comments and criticisms, and finalizing them only at the time of publication. In some cases, due to the vast nature of the scientific production and Santilli’s multiple duties, papers in unedited versions ended up being published in lieu of their final version, thus requiring errata-corrige.

For instance, all preprints Santilli uploaded in various electronic archives were drafts used to solicit critical comments and are, at times, far from the final published versions. Hence, serious scholars should be aware of this occurrence, and verify the final character of the papers prior to expressing their views. In the event verifications of the final character of a given work is needed, scholars are suggested to contact “board(at)santilli-foundation(dot)org”.

I. Gandzha (gandzha@iop.kiev.ua)

and

J. Kadeisvily (ibr@gte.net)

The Institute for Basic Research

35246 US 19 North, No. 215, Palm Harbor, FL 45689, U.S.A.

<http://www.i-b-r.org> , <http://www.santilli-foundation.org/>

December 1, 2010

Chapter 1

INSUFFICIENCIES OF THE 20-TH CENTURY THEORIES

1.1 The Legacy of Lagrange and Hamilton

Santilli conducted his graduate studies in theoretical physics in the late 1960s at the University of Torino, Italy, where J.L. Lagrange lived and did some of his research. In this way, Santilli had the opportunity of studying the original papers by Lagrange (some of which had been written in Italian), thus learning Lagrange's original conception of his celebrated analytic representation of nature (dating to 1788) as requiring *two* quantities:

1) A function $L(r, v) = K(v) - V(r)$, to. day known as the Lagrangian, where $r = (r^k)$, $k = 1, 2, 3$, are the coordinates, $v = dr/dt$ represents the velocity, $K(v) = mv^2/2$ is the kinetic energy, and $V(r)$ represents all action-at-a-distance forces derivable from a potential, plus

2) The *external terms*, $F(t, r, v)$, that is, terms external to his analytic equations representing all forces not derivable from a potential or a Lagrangian.

Santilli then studied in British libraries the original works by W. R. Hamilton and discovered that in 1834 he had essentially the same conception as that by Lagrange for the analytic representation of nature as characterized by a function, today known as the hamiltonian representing the total energy in a space (today called cotangent bundle) with local coordinates r and $p = mv$,

$$H(r, p) = K(p) + V(r) = \frac{p^2}{2m} + V(r), \quad (1.1)$$

plus his celebrated analytic equations, those with external terms representing forces non-derivable from a potential (hereon called “non-Hamiltonian forces”),

$$\begin{aligned}\frac{dr}{dt} &= \frac{\partial H(r, p)}{\partial p}, \\ \frac{dp}{dt} &= -\frac{\partial H(r, p)}{\partial r} + F(t, r, p, \dots).\end{aligned}\tag{1.2}$$

The above analytic representation of nature remained in full force and effect until the early 1900. As an example, C. G. Jacobi formulated his celebrated theorem in 1837, not in the form presented in mechanics books of the 20th century where the external terms are generally removed, but for the *true Lagrange and Hamilton equations*, those with external terms.

The advent in the early 1900 of special relativity and quantum mechanics caused a major alteration of the original analytic conception of nature by Lagrange and Hamilton. In essence, both special relativity and quantum mechanics are strictly Hamiltonian theories, that is, they only admit *one* quantity, a Lagrangian or, equivalently, a Hamiltonian for the entire representation of a system, and show no possibility of accommodating the external terms short of a major structural revision.

Consequently, the widespread posture of the 20th century physics was to eliminate Lagrange and Hamilton external terms and solely work with equations today called the *truncated Lagrange and Hamilton equations*. A general argument was that the forces represented by the external terms are “fictitious” (sic) because, the argument says, when a system in our environment is reduced to its elementary constituents, all non-Lagrangian or non-Hamiltonian forces “disappear” (sic) and nature assumes the analytic structure of the truncated equations.

The first historical scientific contribution by Santilli was to formulate and prove the following theorem showing that the above posture is a mere manifestation of academic politics without scientific credibility. Santilli initiated his research on the following theorem in the late 1960s (see Refs. [30,31,32]); he continued them in 1978 in memoirs [41,42] at the foundations of hadronic mechanics; and he finalized them in various papers (see, e.g., memoir [92] published by the *Italian Physical Society* herein adopted) and in various books (see Refs. [11,12,13]).

THEOREM 1.1: A macroscopic system with forces that are nonconservative and/or irreversible over time cannot be consistently decomposed into a finite number of elementary particles all with solely conservative forces derivable from a potential and, vice versa, a finite number of elementary particles all in conservative conditions cannot consistently yield, under the correspondence principle or other means, a macroscopic system with nonconservative and/or irreversible forces.

The importance of this theorem is set by the fact that the non-Lagrangian or non-Hamiltonian forces of our macroscopic environment, rather than “disappearing” at the particle level to please academia, originate at the most elementary level of nature, thus confirming the depth of the analytic conception of nature by Lagrange and Hamilton.

As an illustration, Santilli’s Theorem 1.1 establishes that the resistance experienced by a spaceship during re-entry in our atmosphere is due to the superposition of a large number of contact, nonlinear, nonlocal and nonpotential interactions between the peripheral atomic electrons of the spaceship and corresponding atomic electrons in the atmosphere.

Another significance of Santilli’s Theorem 1.1 is to establish *ab initio* that special relativity and quantum mechanics are not universal theories valid for all possible conditions in nature until the rest of time, as essentially implied by a widespread posture of the 20th century science, but have instead clear limitations.

Numerous additional historical implications of Theorem 1.1 will be indicated throughout this presentation. At this moment, we merely mention the huge technical difficulties caused by the inclusion of external terms in the analytic equations. In essence, the physics of the 20th century was based on Lie algebras with antisymmetric brackets $[A, B] = -[B, A]$ that appear in the time evolution of a physical quantity $Q(r, p)$ of the truncated Hamilton’s equations, $dQ/dt = [Q, H]$, where the brackets are the celebrated Poisson brackets. The appearance of Lie algebras at the foundation of dynamics, the time evolution, then allowed a rigorous construction of the various aspects of special relativity and quantum mechanics.

Santilli identified since his graduate studies (see the above quoted references) that, when the external terms are added to the analytic equations, the time evolution of a quantity $Q(r, p)$ is given by

$$\frac{dQ}{dt} = \frac{\partial Q}{\partial r} \frac{dr}{dt} + \frac{\partial Q}{\partial p} \frac{dp}{dt} = [Q, H] + \frac{\partial Q}{\partial p} F = (Q, H), \quad (1.3)$$

where $[Q, H]$ are the Poisson-Lie brackets. The huge technical difficulties are then set by the fact that, when the brackets $[Q, H]$ of the truncated equations are extended to the brackets (Q, H) of the true analytic equations, there is the loss of all possible algebras, let alone all Lie algebras, in the brackets of the time evolution because the new brackets (Q, H) violate the conditions for the characterization of an algebra (the distributive and scalar laws).

The loss of all algebras in the time evolution then causes the irreconcilable inapplicability of all Hamiltonian methods and theories developed in the 20th century, including special relativity and quantum mechanics.

Rather than being discouraged by this occurrence, in the 1960s Santilli set as his main research goal the development of covering mathematical and physical

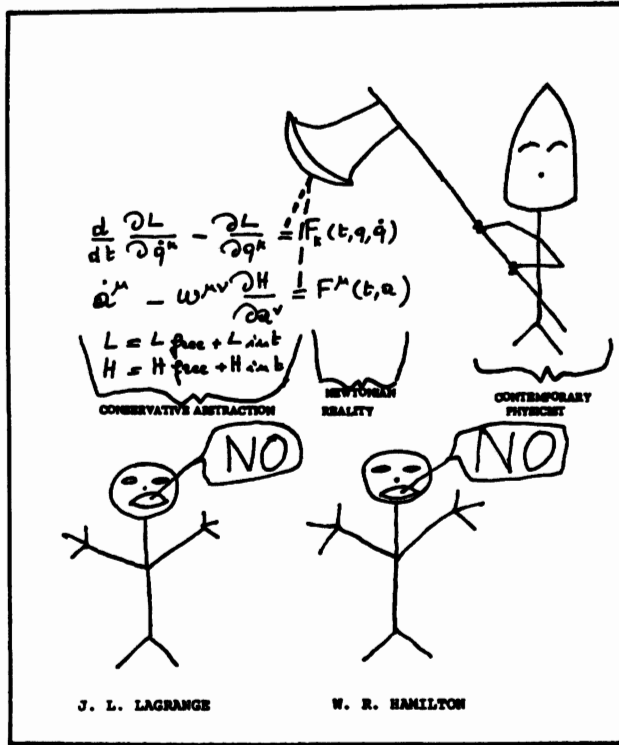

Figure 1.1. The “vignette” presented by Santilli to his colleagues at the Lyman Laboratory of Physics of Harvard University at the initiation of his stay there in September 1977, as part of his research program under DOE support, illustrating the need to study Lagrange’s and Hamilton’s legacy. This study encountered extreme oppositions at Harvard University due to known irreconcilable incompatibilities of Lagrange’s and Hamilton’s external terms with Einsteinian doctrines, quantum mechanics, quantum chromodynamics and all that.

theories suitable for the implementation of Lagrange and Hamilton analytic conception of nature while restoring an algebra in the brackets of the time evolution.

This presentation is essentially a review of Santilli’s studies conducted since that time to achieve the above goal and identify its main implications in various quantitative sciences, as well as its industrial applications for much needed new clean energies and fuels that motivated Santilli’s entire body of research. As he puts it in his works: *Quantitative sciences will never admit final theories. No matter how beautiful any given theory may appear, its structural generalization is only a question of time.*

In the rest of this chapter we review essentially ad litteram the insufficiencies of all quantitative sciences of the 20th century identified by Santilli as the neces-

sary pre-requisite for their resolution via his covering theories, as presented, for instance, in monograph [19].

1.2 Insufficiencies of Galilei and Special Relativity

Santilli has repeatedly stated in his writings that *Galilei and special relativity have majestic axiomatic structures*, for which reason he assumed their axioms for his covering relativities.

However, Galilei's relativity solely admits Galilei invariant forces that are solely derivable from a potential, thus being manifestly inapplicable to interior dynamical systems requiring contact nonpotential forces, as illustrated in Figure 1.2. Therefore, one of the basic discoveries achieved by Santilli has been the broadening of Galilei relativity in such a form to admit all possible (nonsingular) potential and nonpotential forces, while preserving the conventional ten Galilean conservation laws for closed-isolated interior dynamical systems.

Additionally, a widespread belief in the physics of the 20th century has been that special relativity is valid under whatever conditions exist in the universe, to such an extent that the universe has been often adapted to verify special relativity, rather than adapting the theory to physical reality. By contrast, Santilli states:

In vacuum I can easily verify the existence of inertial reference frames, the equivalence of all laws for inertial frames, the absence of a privileged reference frame, the maximal causal value of the speed of light, and the other basic aspects of special relativity.

On the contrary, within physical media such as air or water I cannot even define inertial reference systems due to the evident existence of drag forces, I only have the privileged reference frame locally at rest with the medium, and most physical media are opaque to light, thus preventing any possibility consistent formulation, let alone verification of the basic axioms of special relativity.

Assuming that, somehow, via a currently unknown manipulation, it is possible to bypass No Reduction Theorem 1.1, it is manifestly impossible to introduce inertial reference frames and measuring apparatus, say, to test the physical laws of an electron in the core of a star. The existence of limitations in the exact validity of special relativity are, therefore, beyond any scientific or otherwise credible argument.

An important contribution made by Santilli in physics has been the identification of:

1) The *conditions of clear validity of special relativity*, given by the conditions originally conceived by the founding fathers, namely, for point-particles and electromagnetic waves propagating in vacuum (empty space) or, equivalently, by all conditions in which particles can be well abstracted as being point-like, such as the electron in the hydrogen structure, particles in accelerators, and many

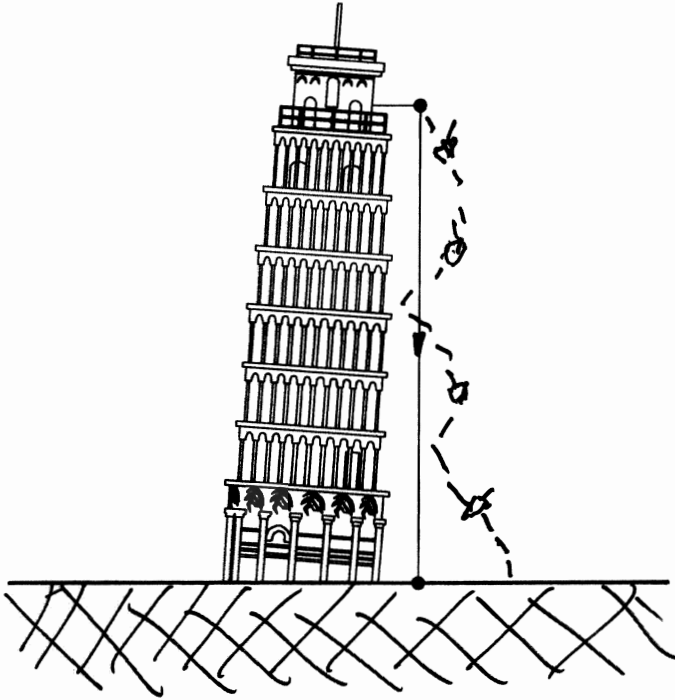

Figure 1.2. A schematic illustration of the tacit assumption in Galilei relativity of ignoring resisting forces in the free fall of massive bodies (here represented with the straight vertical line), as historically was the case in the celebrated experiments by Galileo Galilei in Pisa, while the actual trajectories within our atmosphere depart from such a behavior (here illustrated via the wiggly trajectory of a leaf in free fall in air).

other systems (all conditions historically known as those of *exterior dynamical problems*);

2) The *condition of mere approximate character of special relativity*, given by all conditions of particles at mutual distances equal or smaller than their wavepacket or charge distributions or, equivalently, for the motion of particles and electromagnetic waves within physical media, such as liquids, atmospheres, chromospheres, or the hyperdense media inside hadrons, nuclei and stars (conditions historically known as those of *interior dynamical problems*). These conditions cause mutual penetrations of wavepackets and charge distributions under which particles cannot be effectively approximated as being dimensionless points due to contact, nonlinear, nonlocal and non-Hamiltonian effects expected from Theorem 1.1 and other reasons reviewed in Chaptres 3-9. In particular, special relativity can only be approximately valid for the structure of hadrons, nuclei and stars (see Figure 1.3);

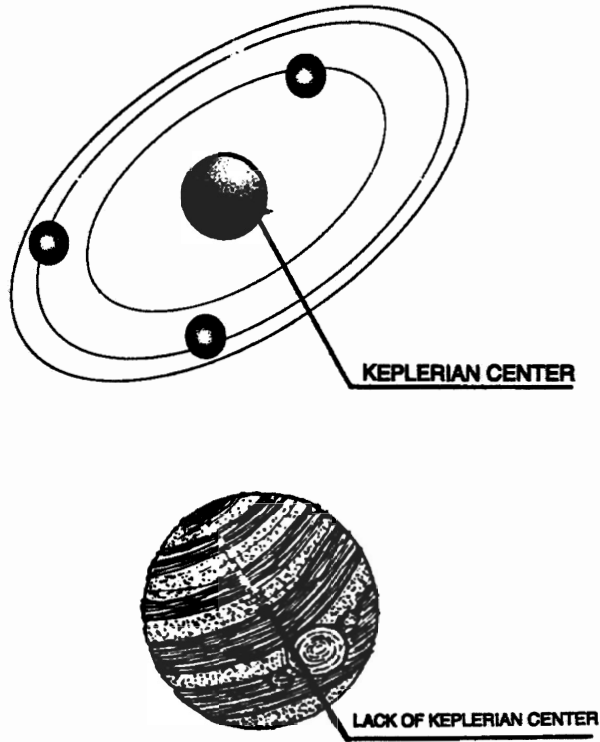

Figure 1.3. A schematic illustration presented by Santilli various times on: the distinction between exterior and interior dynamical problems (see Section 3.12 for definitions); Santilli's acceptance of special relativity for the characterization of Keplerian systems, such as atomic or planetary structures; and Santilli's impossibility to accept special relativity for interior problems, such as those for hadrons, nuclei and stars, due to lack of a Keplerian nucleus with consequential necessary loss of the Lorentz-Poincaré symmetry.

3) The *conditions of inapplicability of special relativity* (and *not* violation because the theory was not conceived for that), such as the classical representation of antimatter (see Section 1.4), irreversible systems such as energy releasing processes, (due to the strictly reversible character of special relativity compared to the strict irreversibility over time of the processes considered), and other conditions presented in Chapter 3.

It should be indicated that Albert Einstein identified quite clearly in his writings the above indicated Conditions 1 for the applicability of his studies. The extension of special relativity to conditions dramatically beyond those identified by Einstein without a serious scrutiny has been perpetrated by *Einstein's follow-*

ers, who are indeed responsible for the scientific obscurantism indicated earlier and documented in more details in the rest of this presentation.

1.3 Insufficiencies of General Relativity

Unlike his view on special relativity, Santilli believes that *Einstein's conception of gravitation via a curved space, despite its unquestionable mathematical beauty, is one of the most controversial theories in history, with fundamental, yet unresolved physical inconsistencies.*

This severe view is motivated by various quantitative studies indicated in more details in Chapter 3. At this introductory stage, we recall Santilli's confirmation that the Riemannian geometry provides a good *mathematical* description of gravity, but Santilli is unable to accept space as being truly curved by gravitation in the actual physical sense because of:

- 1) The impossibility of representing with curvature the weight of bodies when in *stationary* conditions;
- 2) The impossibility of representing with curvature the free fall of bodies along a *straight* radial line;
- 3) The absence of curvature in the bending of light when passing near a celestial body, since that curvature is due to Newtonian attraction, rather than curvature of space as we shall see in Chapter 5, and other reasons.

At a deeper level, it should be recalled that special relativity is physically consistent because it verifies the crucial condition of *invariance over time*, namely, the prediction of the same numerical values under the same conditions but at different times, which invariance is ultimately due to the canonical-Hamiltonian structure of the theory and to its invariance under the Poincaré symmetry.

By contrast, Santilli has proved that the Riemannian geometry does not yield numerical values invariant over time because of the well known fact that the conception of gravitation on a curved space requires a "covariance," rather than a strict invariance, with consequential alteration of numerical values under the same conditions at different times (Section 3.9).

Additionally, the predictions of special relativity under given conditions are unique. By contrast, Santilli has shown that the numerical predictions of general relativity for given conditions are not unique in view of the well known fact that general relativity is a nonlinear theory whose solution requires one or another approximation. It then follows that the numerical predictions depend on the selected expansion as well as the selected parameter for a given expansion.

Santilli has also shown that: general relativity violates the fifth identity of the Riemannian geometry, the Freud identity, for the case of *neutral* bodies (due to the lack of a source tensor in the exterior problem in vacuum); general relativity is incompatible with quantum electrodynamics (also because of the lack of a source tensor in vacuum for neutral bodies); general relativity verifies the *Theorems*

of *Catastrophic Mathematical and Physical Inconsistencies for Noncanonical or Nonunitary Theories* (Section 3.9); and the theory has other basic unresolved problems generally ignored by researchers in the field, thus fueling the indicated scientific obscurantism.

1.4 Insufficiencies of Einstein's Theories for Antimatter

Another reason for the scientific obscurantism of the 20th century is that special and general relativities were widely believed to apply for all possible conditions existing in the universe, while in reality they are unable to provide a valid *classical* representation of antimatter.

In fact, said theories can solely represent antimatter via the change of the sign of the charge. Consequently, said theories provide no distinction whatsoever between *neutral* bodies made up of matter and antimatter. Even when considering charged particles, quantization leads to inconsistencies, due to a resulting "particle" with the wrong sign of the charge, rather than the charge conjugated antiparticle.

In Santilli's words: *One of the biggest scientific imbalances of the 20th century has been the treatment of matter at all possible levels of study, from Newton to second quantization, while antimatter was solely treated at the level of second quantization.* Hence, he decided to resolve this historical imbalance by discovering a new theory of antimatter that, as it is the case for matter, is applicable at all levels of study from Newtonian mechanics to second quantization, and he did indeed achieve such a goal, as we shall see in Section 3.7.

1.5 Insufficiencies of Quantum Mechanics

Santilli has repeatedly stated that quantum mechanics has made historical contributions to mankind, by possessing a majestic axiomatic structure he assumed for the construction of hadronic mechanics, besides having an impressive body of experimental verifications under the conditions of its original conception and construction.

Despite these achievements, physics is a discipline that will never admit final theories valid to the end of time. In fact, Santilli became a physicist because of authoritative doubts on the final character of quantum mechanics expressed during his high school years even in the Italian press for the general public, such as:

A) The view by Albert Einstein on the "lack of completion" of quantum mechanics (in fact, Santilli constructed hadronic mechanics precisely as a "completion" of quantum mechanics in honor of Albert Einstein);

B) The doubts expressed by Enrico Fermi as to whether quantum mechanics holds in the interior of mesons (Santilli quoted repeatedly Fermi's doubt as being at the foundation for his studies on the structure of hadrons);

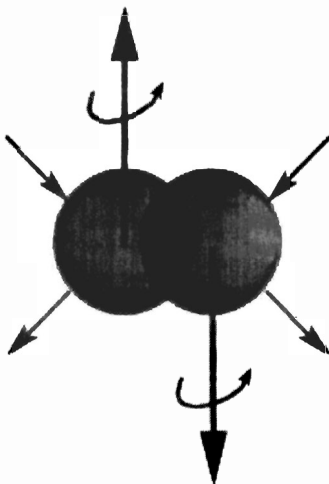

Figure 1.4. The new interactions at the foundations of hadronic mechanics originating from mutual contact and penetration of the wavepackets of particles at short distances that are non-Hamiltonian because nonlinear, nonlocal and nonpotential, thus requiring a nonunitary lifting of quantum mechanics, including its mathematics, physical laws and experimental verifications.

C) The limitations of quantum mechanics voiced by Werner Heisenberg, one of the very founders of the mechanics, from the linear character of the theory compared to the evident nonlinearity of the physical world (Santilli corresponded with Heisenberg on this topic prior to Heisenberg's death in 1976);

D) The authoritative doubt voiced by Paul M. Dirac, another major founder of quantum mechanics, on the need for a revision of the theory permitting convergent perturbative expansions (Santilli met Dirac in Florida in 1982 to discuss the capability of hadronic mechanics to turn divergent quantum series into convergent forms, as reported by Santilli in his books);

E) The arguments by various philosophers of science on the need to surpass quantum mechanics with broader theories, such as Karl Popper, who was a strong supporter of Santilli's proposal to build the hadronic covering of quantum mechanics, as stated in the Preface of his last book of 1978; and other doubts.

With the passing of time, these authoritative doubts were first ignored; then the authors were discredited via the abuse of academic authority, including the discreditation of Heisenberg, Dirac, Popper and other famous scientists for the lack of alignment of their views with the predominant political lines of the academic time; and any additional qualified doubt was prohibited to appear in print in the journals of leading physical societies, while its appearance in the press was opposed or discredited.

This evident organized manipulation of scientific knowledge and suppression of scientific democracy of qualified inquiries for personal interests led to the widespread assumption in the last part of the 20-th century that quantum mechanics (and its Galilean and special relativity backgrounds) are the final theories for all possible conditions existing in the universe to the end of time, resulting in a manifest scientific obscurantism of historical proportions.

It is a duty of future historians to identify the reasons for the suppression of these authoritative doubts, as well as the responsibilities by leading academic institutions and governmental agencies funding the research, by identifying the origination of the rather universal trend of adapting all possible conditions in the universe to verify quantum mechanics and its underlying relativities.

A notorious exception is that by Santilli who honored the indicated authoritative doubts, conducted comprehensive mathematical, theoretical and experimental research on the limitations as well as the surpassing of quantum mechanics in a way completely oblivious to organized ascientific interests, and did indeed change the history of physics, as we shall see.

To begin our review in the field, another major scientific contribution by Santilli has been the restoration of a serious scientific process on quantum mechanics and its underlying relativities as follows:

1) A theory is said to be *exactly valid* for given conditions when it represents the *totality* of the physical data from primitive axioms without adulterations (such as throwing into the equations unknown parameters, arbitrary functions, and the like). This is the case for the structure of the hydrogen atoms, particles in accelerators, crystals, and numerous other systems. By analyzing the local-differential topology and mathematics underlying the theory, Santilli has confirmed that the conditions for the exact validity of quantum mechanics are the same as those for special relativity (as expected from the deep synergy of these theories), namely, quantum mechanics can be safely assumed to be exactly valid for particles and electromagnetic waves propagating in empty space or, more generally, for particles at mutual distances sufficiently bigger than their size and/or charge distribution to allow their effective point-like abstraction.

2) A theory is said to be *approximately valid* when the representation of experimental data requires ad hoc parameters and/or arbitrary functions that are then fitted from the data themselves (this is the case for numerous events in particle physics, nuclear physics, astrophysics and other disciplines). In particular, Santilli has proved that said arbitrary parameters and/or functions are, in reality, a direct measure of the *deviations* of the basic axioms of the theory from the system at hand. Numerous illustrative examples in both quantum mechanics and quantum chemistry were then worked out (see the Chapters 3, 4, 5).

3) A theory is said to be *inapplicable* (rather than “violated”) when the parameters thrown into the equations are incompatible with the basic axioms, or

the theory does not admit any quantitative representation at all of experimental data. Illustration cases of inapplicability of quantum mechanics are the following:

3A) The use of the four parameters (called “chaoticity parameters”) necessary for the quantum mechanical representation of the experimental data via the Bose-Einstein correlation is prohibited by quantum axioms, because the two point correlation function for a two-dimensional Hermitean (thus diagonal) operator could at best admit two parameters. Hence, the additional two parameters needed for the representation must be off-diagonal, thus being in direct violation of the axiom of vacuum expectation values for a Hermitean operator;

3B) Quantum mechanics is inapplicable for the synthesis of the neutron from a proton and an electron as occurring in stars because, in this case (kept quite secret by academia, the Schrödinger equation becomes inconsistent, an occurrence that is the historical motivation for the very birth of the covering hadronic mechanics, as we shall see;

3C) Quantum mechanics is inapplicable for all processes that are irreversible over time, such as nuclear fusions, because quantum mechanics is reversible over time, thus admitting the time reversal event (such as the synthesized nucleus spontaneously decomposing itself into the original two nuclei) with embarrassing violations of energy conservation, causality and other basic laws.

By looking in retrospect at a lifetime of research, we can quote Santilli’s statement that: *The selection of the appropriate generalization of quantum mechanics for physical conditions more complex than those of its conception and experimental verification, should indeed be the subject of scientific debates, but the aprioristic assumption of quantum mechanics as being exact for all conditions existing in the universe is ascientific, amoral and asocial, particularly when ventured by physicists at leading academic institutions.*

1.6 Insufficiencies of Nuclear Physics

The contributions of quantum mechanics to nuclear physics are well known, the most notorious being the atomic bomb and nuclear power plants. Santilli points out that these events deal with *fission processes* whose debris admit a good approximation as being point-like, thus allowing quantum mechanics to be effective.

As a result of said historical achievements, quantum mechanics was assumed throughout the 20-th century as being exactly valid for all possible nuclear structures and processes. Yet, Santilli pointed out that quantum mechanics cannot possibly be exactly valid for *fusion processes*, since the theory is reversible over time. Thus, jointly with the probability of nuclear syntheses of two nuclei into a third, $N_1 + N_2 \rightarrow N_3$ plus energy, quantum mechanics admits a finite probability for the *spontaneous* time reversal reaction

$$N_3 \rightarrow N_1 + N_2 \tag{1.4}$$

in fragrant disagreement with the conservation of energy and other laws, trivially, because the probability amplitude does not depend explicitly on time.

With the understanding that the *approximate* validity of quantum mechanics in nuclear physics is out of question, Santilli believes that one of the most pernicious manifestations of the scientific obscurantism of the 20th century existed in nuclear physics, due to the religious assumption of the exact validity of quantum mechanics in the field when quantum mechanics has failed to achieve an exact representation of all experimental data of the simplest possible nucleus, the deuterium, because:

1) Quantum mechanics has been unable to represent the spin 1 of the deuterium since quantum axioms require that the sole stable bound state of two particles with spin 1/2, the proton and the neutron, must be the singlet state with spin zero;

2) Quantum mechanics has been unable to represent the magnetic moment of the deuterium despite 100 years of research and the use of all possible relativistic corrections;

3) Quantum mechanics has been unable to explain the stability of the neutron when coupled to the proton in the deuterium, since the neutron is a naturally unstable particle (when isolated) with about 14 minutes lifetime; and other insufficiencies.

The assumption of quantum mechanics as being exactly valid in nuclear physics reaches historical proportions when proffered by experts in the field from authoritative academic institutions, or by editors of leading physics societies, when one considers that the huge deviations of quantum mechanics from the experimental data of large nuclei, such as the zirconium.

Santilli qualifies as distressing the inability by quantum mechanics to reach a serious understanding of the nuclear force, because quantum mechanics is strictly Hamiltonian, as indicated above. Hence, all research over the past century has been studiously restricted to represent the nuclear force with a potential. The impossibility of representing experimental data then forced the addition of more and more potentials, to the extreme that nuclear forces have recently reached up to 35 different potentials without achieving the needed exact representation,

$$H = \frac{p^2}{2m} + V_1 + V_2 + V_3 + V_4 + V_5 + V_6 + V_7 + V_8 + V_9 + V_{10} + V_{11} + V_{12} \quad (1.5)$$

$$+ V_{13} + V_{14} + V_{15} + V_{16} + V_{17} + V_{18} + V_{19} + V_{20} + V_{21} + V_{22} + V_{23} + V_{24} +$$

$$+ V_{25} + V_{26} + V_{27} + V_{28} + V_{29} + V_{30} + V_{31} + V_{32} + V_{33} + V_{134} + V_{35} + \dots$$

To express his distress, Santilli states: *There is a limit in the political manipulation of scientific knowledge and its adaptation to preferred theories, rather than adapting the theories to physical reality no matter how beloved the theories are, beyond which limit all credibility is lost to such an extent of raising issues*

of scientific ethics and accountability, particularly when the manipulation is perpetrated under public financial support. In fact, the insufficiency of potentials to represent nuclear forces squarely brings into focus Santilli's Theorem 1.1 on the origin of nonconservative/nonpotential forces at the very structure of matter, thus including nuclear structures. Above all, Santilli has never accepted quantum mechanics to be exactly valid for nuclear physics because its basic symmetries, the Galilei and the Poincaré symmetries, solely apply for *Keplerian systems*, thus requiring a nucleus, and states: *Quantum mechanics cannot possibly be exactly valid for nuclear structures because nuclei do not have nuclei, as a consequence of which the basic Galilean and Poincaré symmetries must be broken, thus causing incontrovertible deviations from quantum axioms.*

As we shall see in Chapter 3, the “completion” of quantum mechanics into a covering mechanics achieving an exact representation of nuclear data permits the prediction and quantitative treatment of new clean energies so much needed by our society. Hence, the resolution of the approximate character of quantum mechanics in nuclear physics has major societal, let alone physical relevance.

By following Santilli, we can again state that the selection of a mechanics more adequate than quantum mechanics for nuclear structures should indeed be the subject of scientific debates, but the aprioristic assumption of quantum mechanics as being exactly valid in nuclear physics creates serious problems of scientific ethics and accountability (with inevitable legal overtones).

1.7 Insufficiencies of Particle Physics

In Santilli's view, the biggest scientific obscurantism exists in particle physics with particular reference to claimed “experimental results” for high and very high energy particle collisions, and/or deep inelastic scattering, that he calls “*experimental beliefs.*”

The argument is that all these data are based on the use of the conventional *potential scattering theory*, namely, a theory based on the religious assumption that particles remain point-like also under very high energy collisions (a condition necessary to apply quantum mechanics) and, as such, the particles solely experience action-at-a-distance interactions derivable from a potential.

In his own words, Santilli states: *According to the axioms of quantum mechanics and their consequential point-like abstraction of particles, neutral particles can have no scattering at all since dimensionless points cannot affect the trajectory of other dimensionless points, while charged particles can only have Coulomb scattering at all energies. Therefore, the very existence of deviation from these basic lines in scattering experiments establishes beyond credible doubt the presence of non-Hamiltonian effects in deep mutual penetrations of the wavepackets and/or charge distributions of particles.*

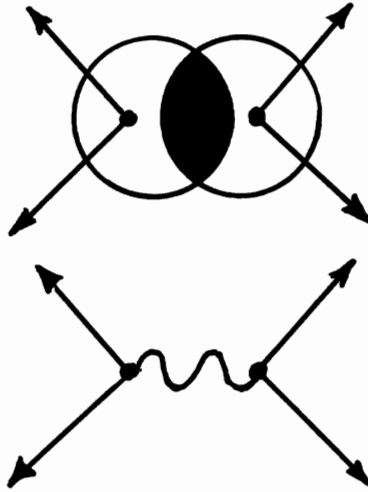

Figure 1.5. An illustration of the reason Santilli cannot accept the experimental data, let alone the basic theories, of the 20th century particle physics, illustrating the point-like abstraction of particles and their wavepackets (below), compared to the necessary deep overlapping of said wave-packets and/or charge distributions in high energy scattering experiments (above). Incontrovertible experimental evidence for deviations in scattering experiments from a point-like behavior establish the merely approximate character of the potential scattering theory and related lack of final character of the claimed “experimental results.” Additionally, Santilli cannot accept 20th century particle physics due to its irreconcilable incompatibility with other branches of physics, such as: incompatibility with Newtonian mechanics due to Theorem 1.1; incompatibility with thermodynamics due to the strict reversibility over time of particle physics compared with the irreversibility of thermodynamics; etc.

The electron has an extended wavepacket irrespective of its point-like charge. But at sufficiently low mutual distances, electrons have scattering trajectories departing from the Coulomb behavior, thus establishing on serious scientific grounds beyond academic politics that the conventional, potential scattering theory can only be *approximately valid* for high energy scattering experiments, since it is notoriously unable to incorporate nonpotential/non-Hamiltonian effects due to mutual wave overlappings.

When passing from the electron point-like charge to scattering experiments of particles with extended charge distributions such as hadrons, the insufficiencies of the conventional potential scattering theory raise clearly historical problems of scientific ethics and accountability due to very large public sums current spent by high energy physics laboratories around the world that release “experimental beliefs” without any serious appraisal of the theoretical theologies used for the claimed results.

We hope the reader begins to see in this way additional historical implications of Santilli's Theorem 1.1, since it requires the emergence of nonpotential forces precisely at the level of deep inelastic scattering or collisions, as it is the case of the spaceship during re-entry in our atmosphere. But these forces are non-Hamiltonian, thus requiring a necessary *nonunitary covering of the scattering theory*, which is one of the primary objective of hadronic mechanics in view of its nonunitary structure.

Whatever *nonunitary scattering theory* emerges to be correct for high energy particle scattering experiments, it is clear that it will mandate a re-inspection of all "experimental beliefs" in particle physics to ascertain whether the results claimed under sole potential forces are exact or merely approximate, thus in need of basic revisions of the numerical results.

1.8 Insufficiencies of Quarks and Neutrinos Conjectures

Santilli has always accepted SU(3)-color theories as providing the final Mendeleev-type classification of hadrons into families; has accepted quarks as being necessary for the elaboration of said Mendeleev classification; but he has never accepted quarks as being physical particles actually existing in our spacetime for numerous reasons, such as:

a) Quark can only be technically defined as purely mathematical representations of a purely mathematical internal symmetry, defined on a purely mathematical internal, complex-valued unitary space, without any possibility of being consistently definable in our spacetime (because prohibited by the Poincaré symmetry and other reasons);

b) Quarks cannot have any gravity because, as stated by Albert Einstein, gravity can be solely defined for masses in our spacetime, while quarks cannot be seriously defined in our spacetime.

c) Nuclei, atoms and molecules have required one model for their classification into family and a *different*, yet compatible model for the structure of each individual element of a given family, and the same occurrence is expected for the classification and structure of hadrons.

To illustrate the basic dichotomy classification versus structure, Santilli has stated that: *If one of my graduate students would ask me to supervise a thesis whereby the Mendeleev table for atoms is also used for the structure of each individual atoms of a given family, I would immediately request his/her expulsion from the department, because classification and structure are dramatically different problems, requiring dramatically different methods and theories.*

In fact, the Mendeleev table was formulated via classical chemical and other methods, while the structure of the atoms required the advent of quantum mechanics. As we shall see, we have a very similar situation for hadrons because the linear, local and Hamiltonian character of quantum mechanics is effective

for the classification of hadrons under their point-like approximation, but the same mechanics has been shown to be inadequate for structure problems due to inevitable nonlinear, nonlocal and non-Hamiltonian effects occurring within hyperdense media inside hadrons.

Santilli has additionally stated: *According to the standard model, at the time of the neutron synthesis from protons and electrons inside a star, the permanently stable protons and electrons simply “disappear” (sic) from the universe to be replaced by conjectural quarks, and then the proton and the electron simply “reappear” (sic) at the time of the neutron decay. These beliefs are simply repugnant to me because excessively irrational, thus showing the conduction of particle physics via academic authority, rather than scientific veritas.*

Similarly, Santilli never believed that the neutrinos are physical particles in our spacetime for numerous reasons, the first being the fact that the neutrino is assumed to be *emitted* during the synthesis of neutrons from protons and electrons inside stars,



while a more correct assumption should have been its *absorption*, because the neutron is 0.782 MeV *heavier* than the sum of the rest energies of the proton and the electron,

$$E_p = 938.272 \text{ MeV}, \quad E_e = 0.511 \text{ MeV}, \quad E_n = 939.565 \text{ MeV}, \quad E_\nu = ?. \quad (1.7)$$

As a result, quantum mechanics is basically inapplicable for any quantitative treatment of synthesis (1.6) for various reasons, such as:

A) All bound states characterized by quantum mechanics (such as nuclei, atoms and molecules) must have a “mass defect,” namely, the rest energy of the resulting state must be smaller than the sum of the rest energies of the constituents, resulting in the familiar “negative binding energy.” By contrast, reaction (1.6) requires a kind of “mass excess,” thus requiring a “positive binding energy,” under which the Schrödinger and other equations of quantum mechanics become inconsistent.

B) The assumption of the “missing energy” of 0.782 MeV as being provided by the relative kinetic energy of the proton and the electron is inconsistent and untenable, because at that energy the cross section of protons and electrons is virtually null, thus prohibiting any bound state;

C) The belief that the conjugate expression



where $\bar{\nu}$ denotes antineutrino, is political and equally inconsistent, because the antineutrino has an identically null cross section with the proton and the electron, thus being unable to provide them the missing energy. In any case, recent studies have established that antineutrinos should have a *negative mass referred to a*

negative unit as a necessary condition to achieve a classical theory of antimatter (see Chapters 2, 3), thus requiring, rather than providing energy for the neutron synthesis.

The advent of the standard model has caused additional, rather serious, unresolved problems because Fermi's original conception of *one* massless and chargeless neutrino and its antiparticle had to be first extended to three different neutrinos and their antiparticles without any serious identification of their differences; then this enlargement had to be further enlarged to admit that neutrinos have masses; then the latter enlargement had to be further broadened with the additional belief that neutrinos have different masses; then the latter assumption had to be further modified with the conjecture that neutrinos "oscillate" (that is, change from one form into the other); with the expectation of additional unverifiable conjectures introduced to bypass the problems unsolved by the preceding conjectures, yet under very large public funds dispersed at major international laboratories on these pure theoretical theologies without any serious scrutiny by society, thus confirming the ongoing scientific obscurantism.

Any denials of the need for a basic re-inspection of physical laws for the most fundamental synthesis in nature, that of the neutron, can only raise serious problems of scientific ethics and accountability (also with inevitable legal overtones).

Santilli states: *Until I live, I will refuse to accept that very large fluxes of massive particles, such as neutrinos originating from stars, are believed to traverse entire planets and stars, thus passing through an enormous number of nuclei, without any collision at all. Instead of accepting such a theology, I will look for alternative theories more plausible than that of the neutrinos.* So, in fact, he did, by introducing his theory of "longitudinal" impulses propagating through the ether as a universal substratum, thus explaining the lack of collision (see Chapters 3, 5).

Unreassuringly, Santilli has also stated that: *Quarks and neutrinos have been claimed to exist as physical particles in our spacetime by organized high ranking academic interests because their assumption is essential to preserve the validity of special relativity and quantum mechanics. In any case, the various claims of leading particle laboratories to have "discovered" or "detected" this or that quark is extremely anti-scientific for me because the correct scientific statement should have been that of having detected physical particles in our spacetime "predicted" by quark conjectures, with the understanding that the same particles could be predicted by other conjectures. In the final analysis, the conjecture that quarks are physical particles in our spacetime prohibits the study of possible new clean energies because quarks must be assumed as being permanently confined in the interior of hadrons, while all energies obtained from nuclear, atomic and molecular structures are based on the capability of extracting the constituents free.*

1.9 Insufficiencies of Quantum Chemistry

As it is well known, quantum chemistry has also made historical contributions to society, but this is no reason to expect that quantum chemistry is the final theory for all chemical processes until the end of time. In fact, beginning with the time of his graduate studies in the 1960s, Santilli never accepted quantum chemistry as a final discipline for numerous reasons he has identified in his works. For instance, he states that:

The fundamental quantum chemical notion of valence bond, as presented in the 20th century literature, is a pure nomenclature without quantitative content because, to be quantitative, the notion should:

- 1) *Identify clearly the force between two identical valence electrons;*
- 2) *Prove that such a force is attractive, as an evident necessary pre-requisite to claim the bond needed for a molecule; and*
- 3) *Prove that such a clearly identified clearly attractive force verifies indeed experimental data on molecular structures.*

These conditions are impossible for quantum chemistry, because two identical electrons must "repel" each other according to quantum mechanics, and they cannot possibly "attract" each other.

Therefore, Santilli set his goal to achieve the missing quantitative notion of valence, and he did achieve it, as we shall see in Chapter 4, giving birth to the new discipline of hadronic chemistry.

Santilli has also identified additional structural problems of quantum chemistry, among which most visible is the prediction (verified by one of his graduate students) that all substances are paramagnetic, in great disagreement with evidence establishing that only certain substances are paramagnetic.

This insufficiency can be verified with the hydrogen molecule that is indeed diamagnetic. The origin of the problem rests in the absence of a clearly identified, sufficiently "strong" valence bond among the pair of valence electrons of the H_2 molecule, as a result of which the orbitals of individual hydrogen atoms remain essentially independent, thus available for a joint polarization via an external magnetic field, contrary to evidence.

Santilli had another graduate student prove that, under the current notion of valence, there is no reason to have the sole molecule H_2 , since it is possible to bond together three, four or more hydrogen atoms, contrary to evidence. The origin of this additional insufficiency is, again, the lack of a "strongly" attractive valence bond restricting the correlation to valence electron "pairs" only, thus allowing the bonding of additional electrons, contrary to evidence (as we shall see in Chapter 4, the species H_3 , H_4 at times detected in gas chromatography have been proved by Santilli to have a bond other than that of valence).

Additionally, Santilli proved that *quantum chemistry cannot be exactly valid for the study of chemical reactions*, by showing that, jointly with the prediction

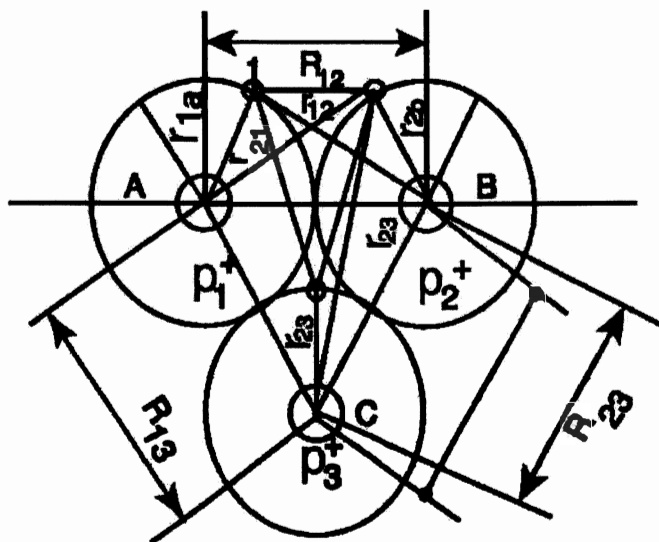

Figure 1.6. An illustration of the fact, actually proved by one of Santilli's graduate students, according to which the 20th century notion of valence in quantum chemistry predicts the capability of bonding hydrogen atoms into clusters H_n with an arbitrary number n of constituents, contrary to the evidence that the sole stable hydrogen molecule is H_2 . The occurrence is a direct consequence of the absence in the 20th century notion of valence of the restriction of the bond to individual pairs of valence electrons. Independently from all the above, identical electrons are predicted by quantum mechanics to repel and certainly not to attract each other, thus establishing truly fundamental insufficiencies in the most fundamental notion of 20th century quantum chemistry.

of the synthesis of the water molecule $H_2 + O \rightarrow H_2O$, quantum chemistry admits a finite probability for the time reversal event, the *spontaneous* disintegration of the water molecule into its original constituents,



in dramatic violation of the principle of conservation of the energy. The reason is well known, but kept a great secret in advanced chemistry departments and laboratories, namely, the fact that quantum chemistry is a theory reversible over time, while chemical reactions, such as the synthesis of the water molecule, are strictly irreversible processes.

It is then evident to all serious scholars outside academic politics that quantum chemistry cannot possibly be the final theory for chemistry, the most serious limitations occurring for chemical reactions. Of course, the applicable new chemistry is open to scientific debates, but the denial of its need can only raise issues of scientific ethics and accountability (again, with inevitable legal overtones).

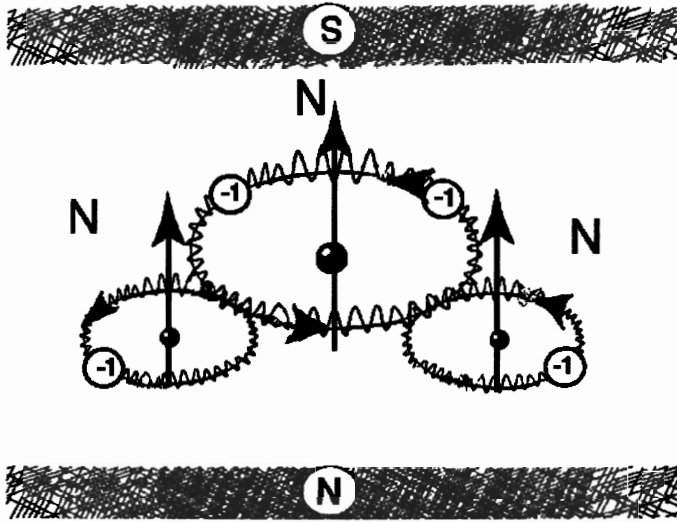

Figure 1.7. A view used by Santilli to illustrate the prediction by quantum chemistry that all substances, such as water, are paramagnetic, in dramatic disagreement with evidence. The prediction is a consequence of the lack of a “strongly” attractive force between valence electron “pairs,” as occurring in nature, in which absence valence electrons remain essentially independent, thus capable of acquiring a magnetic polarization, of course, under a sufficiently strong external magnetic field.

1.10 Insufficiencies of Biology

Among all sciences of the 20th century, that considered most distressful by Santilli is biology treated via quantum mechanics. In fact, he writes: *Had quantum mechanics been applicable to biological processes, my body should be perfectly rigid and perfectly eternal.*

This insufficiency is due to the well known incompatibility of quantum mechanics with the deformation theory (since deformations would cause the breaking of its central pillar, the rotational symmetry), as a result of which quantum mechanics is ideally suited to represent rigid structures such as crystals. Additionally, the insufficiency originates from the reversibility of quantum mechanics over time, compared to the finite life of all biological processes.

Particularly distressing for Santilli is the study of the DNA structure via the elementary mathematics of the 20th century, such as conventional numbers dating back to pre-biblical times, while the complexity of biological processes is simply beyond our imagination at this time.

1.11 Insufficiencies of Astrophysics and Cosmology

According to Santilli, the climax of the scientific obscurantism of the 20th century can be seen in astrophysics and cosmology, because these disciplines have seen true extremes in the adaptation of the universe to verify Einsteinian doctrines without a serious scrutiny.

To begin, the study of the antimatter component of the universe, the consequential expected existence of antigravity between matter and antimatter and related topics, have been systematically ignored because notoriously not compatible with Einsteinian doctrines (Sections 2.4 and 3.7).

Additionally, Santilli has shown that the ongoing views on the expansion of the universe, the acceleration of the expansion with the distance, and the so-called "big bang" theory, are a consequence of the studious intent of preserving the constancy of the speed of light throughout the universe. On serious scientific grounds, we can say that *the speed of light is indeed a constant under the conditions established by experiments until now, when propagating in vacuum conceived as a totally empty space.*

However, Santilli insists that the claim of "the universal constancy of the speed of light" without the crucial words "in vacuum" has a political, rather than a scientific character because disproved by evidence when dealing with propagation of light within physical media. It is today well established that the speed of electromagnetic waves $C = c/n$ has the constant value c only in vacuum, while having otherwise a locally varying character depending on the characteristics of the medium in which it propagates represented by the index of refraction n . Santilli argues that at intergalactic distances, space cannot be considered empty, thus voiding the foundations of current cosmological theologies.

Additionally, Santilli has shown (see Chapter 6) that: the ongoing theology on "dark matter" is a direct consequence of the studious intent of maintaining the constancy of the speed of light also within the physical medium inside a galaxy; the additional theology of "dark energy" is due to the additional studious assumption of maintaining the conventional speed of light in vacuum as equally valid in the interior of gravitational collapse and black holes; and that the assumption within physical media, particularly within the hyperdense media as in the interior of a black holes, of a maximal causal speed different than that in vacuum completely eliminates any need for the hyperbolic "dark matter" and "dark energy."

Above all, one of Santilli's major contribution in astrophysics and cosmology has been the focusing of the attention on ether as a fundamental universal medium (substratum) with very high energy density. A star at its initiation synthesizes from hydrogen a very large number of neutrons estimated to be of the order of 10^{50} neutrons per second or more. But the synthesis of a neutron requires 0.782 MeV, as noted above. According to orthodox views the missing energy

is provided by the star environment. However, in this case a star could never initiate to produce light, since at its initiation the star would *lose* (rather than produce) energy at the rate of 10^{50} MeV per second or more.

The sole possibility for a scientific solution of this fundamental problem is the ether conceived as a universal substratum with very large energy density whose study is seen by Santilli as the ultimate frontier of knowledge, with possible advances simply beyond our most vivid imagination at this time, such as possible longitudinal communications through space at speeds millions of times bigger than that of the transversal electromagnetic waves, or travel to the stars at unrestricted speeds without fuel tanks (Santilli isogeometric propulsion, see Chapter 2) because the needed propulsion and energy may be available everywhere in the ether, provided, of course, we have basically new theories suitable for a serious study of these advances.

As we shall see, one of the ultimate motivations for the construction of hadronic mechanics has been to provide means for quantitative studies of possible interchanges between the ether as a universal substratum and the visible world, a study definitely not possible with quantum mechanics.

1.12 Introductory Readings

Scholars with a serious interest in acquiring an in-depth knowledge of Santilli's discoveries, are suggested to initiate their study with introductory readings, rather than with technical treatments, since the latter may appear as being disconnected from the actual scientific edifice.

A comprehensive technical presentation of said insufficiencies can be found in monograph [20] available for free download in pdf format.

Santilli has been one of the first scientist to present in 1981 various arguments according to which quarks cannot be physical particles in our spacetime (see paper [48]).

A detailed technical treatment of the insufficiencies of 20th century theories and a denunciation of their lack of their addressing dated 1984 was presented by Santilli in book [5] also available in free pdf download.

The related 1,315 pages long documentation dated 1985 is also available in free pdf download [6–8]. The Foundation is attempting to secure copies of Santilli's personal documentation following 1985 that has been donated to a European Institution.

As an example of numerous available qualified doubts on the status of the 20th century science, it is recommendable to read book [190] by J. Dunning-Davies of the University of Hull, England, and references quoted therein.

In this presentation, we follow Santilli in using the terms "Einstein's special relativity" for political parlance, since special relativity was initiated by Lorentz, received major contributions by Poincaré and was completed by Einstein without

quotation of Poincaré's contributions (despite existing correspondence prior to 1905), with additional contributions by Minkowski, Weyl and others. Therefore, an appropriate scientific name should be the *Lorentz-Poincaré-Einstein special relativity*.

For historical accounts outside manipulations of scientific history by organized academic interests, the Foundation suggests the reading of book [189] by A. A. Logunov, Director of the High Energy Physics Laboratory of Protvino, Russia, and references quoted therein.

Chapter 2

SANTILLI'S DISCOVERIES IN MATHEMATICS

2.1 Foreword

Santilli has repeatedly stated that: *The origin of protracted controversies or unsolved problems in physics, chemistry, biology, and other sciences, is generally due to the use of mathematics basically insufficient for the quantitative treatment of the problem at hand, with consequential need to develop new appropriate mathematics.*

Most of the insufficiencies of the 20th century theories identified in the preceding chapter see their origin precisely in the lack of adequate mathematics, such as: the reconstruction of an algebra in the brackets of the time evolution of the analytic equations with external terms, Eq. (1.3), clearly requires the development of a suitable new algebra other than Lie algebra; the classical and operator treatment of nonlinear, nonlocal and non-Hamiltonian interactions for extended particles at short mutual distances (Figure 1.3) clearly requires a mathematics broader than that effective for conventional Hamiltonian and quantum theories; the insufficiencies of curvature to represent gravitation, combined with the inability by general relativity to reach a grand unification and a quantum version of gravity dating back to Einstein's times without solution, are a clear manifestation of the need for a more appropriate geometry for gravitational events; and the same occurs for other problems whose solution is impossible with the mathematics of the 20th century.

Santilli has also stated repeatedly in his writings that: *There cannot be a really new theory without a really new mathematics, and there cannot be a really new mathematics without new numbers.* Hence, as a theoretical physicist, he devoted the majority of his time to the search of new numbers, and then to the construction of new mathematics based on them. Discoveries in physics, chemistry, biology, astrophysics and engineering required the minority of his time.

To understand the mathematical discoveries outlined below, one should keep in mind the main problem investigated by Santilli. Recall from Section 1.1 the legacy of Lagrange and Hamilton according to which the representation of nature requires the knowledge of *two* quantities, a Lagrangian or a Hamiltonian and the external force $F(t, r, p, \dots)$. Recall also from Eq. (1.3) that the presence of the external forces causes the loss of all algebras in the brackets of the time evolution of physical quantities, thus preventing the construction of physically meaningful covering theories.

Hence, Santilli set his research goal to identify an *identical* reformulation of Hamilton's equation (1.2) depending on a second quantity, besides the Hamiltonian, capable of restoring an algebra in the brackets of the time evolution and that algebra had to be a covering of the Lie algebra.

After extensive research and the systematic investigations of all possible alternatives, Santilli finally assumed *the representation of Lagrange's and Hamilton's external forces via a generalization of the basic unit into a form explicitly dependent on local variables generally used in physics, hereon denoted $\hat{I}(t, r, p, E, \dots)$* . All other alternatives failed because of their *lack of invariance over time*, that is, the inability to predict the same numerical values under the same conditions at different times, thus being physically inconsistent.

By comparison, the unit is the most fundamental invariant of all theories, thus being the best solution for the preservation of the same time invariance as that of the truncated analytic equations. However, *the generalization of the basic unit requires a corresponding, progressive, and systematic generalization of the totality of the mathematics of the 20th century, and this explains the dimension as well as novelty of Santilli's mathematical discoveries*.

In this chapter we outline the rudiments of *Santilli mathematics*, at times also called *hadronic mathematics* to indicate the mathematics underlying hadronic mechanics, namely, we shall outline the formulation of numerical fields, vector and metric spaces, geometries, algebras and groups, etc., when characterized by a basic unit $\hat{I}(t, r, p, E, \dots)$ that, besides being nowhere singular, has otherwise an unrestricted functional dependence on all needed local variables. The application of Santilli mathematics for the resolution of Lagrange's and Hamilton's legacy is outlined in Chapter 3.

Mathematicians should be aware that all *mathematical* discoveries outlined in this chapter originated from specific *physical* needs following clear insufficiencies of the pre-existing mathematical and physical methods. Mathematicians should also keep in mind that Santilli has been a member of the Department of Mathematics of Harvard University from 1978 to 1983 under DOE financial support, thus having all qualifications for mathematical discoveries even while being a theoretical physicist. Nevertheless, mathematicians should keep in mind that, except a number of papers written in pure mathematics language for mathematicians,

numerous mathematical discoveries were presented by Santilli in papers intended for physicists and published in physics journals, the understanding being that their re-elaboration in the language of pure mathematics is elementary.

In this mathematical chapter, the conventional associative multiplication “ ab ” of two generic quantities a , b (such as numbers, matrices, operators, etc.) will be denoted with the symbol “ $a \times b$ ” in order to differentiate it from various new multiplications discovered by Santilli that are still associative, yet more general than the trivial multiplications ab .

A main criticism ventured in academia interested in preserving old mathematics (but not in the industry) is that *Santilli's new mathematics is trivial because it boils down to “putting a hat on symbols” without major changes of pre-exciting axioms*. As we shall see, the statement is technically correct for the isotopies (but not for the genotopies or hyperstructures) because Santilli's various different mathematics can indeed be presented by putting “hats” or other indices in pre-existing mathematical symbols.

However, on mathematical grounds the statement is inappropriated and manifestly biased when proffered by expert mathematicians because the implications are far from being trivial. For example:

A) The placement of Santilli's “hat” (meaning isotopy) on the symbols of Lie's theory allows the extension of the applications from linear systems to all possible (well behaved) nonlinear systems, a discovery far from being trivial;

B) The placement of Santilli's “hat” in the symbols of the symplectic geometry renders the same universal for the characterization of all possible (well behaved) non-Hamiltonian system directly in the frame of the experimenter and without any use of the transformation theory, a result with historical mathematical significance (since the symplectic geometry is rendered directly universal) and industrial implications (since for the first time the optimal control theory is applicable to the real non-Hamiltonian systems of our real environment);

C) The placement of Santilli's “hat” in the symbols of special relativity extend its applicability from dynamics in vacuum to dynamics within physical media with implications such as the elimination of “dark matter” and “dark energy”, the development of basically new, environmentally clean and cost competitive new fuels and energies (Chapter 7), a discovery of clear historical proportion and implication rather than of trivial character.

In reality, the greatness of Santilli's mathematical discoveries, nowadays internationally known and acclaimed, has been precisely that of achieving a formulation of his various new mathematics that coincides at the abstract realization-free level with conventional mathematics, thus essentially discovering *new realizations* of pre-existing abstract mathematical axioms, with consequential far reaching mathematical and physical implications.

2.2 Discovery of New Numbers

2.2.A Discovery of isonumbers (1983)

Numbers are at the foundation of all quantitative sciences since, by definition, the latter require mathematical elaborations predicting numbers that can be verified with experiments. For various topological and other technical reasons, experimental measurements requires the adopted “ordinary numbers” (hereon referred to those with characteristic zero and denoted with the letter n) to verify the axioms of a numerical field $F(n, \times, I)$ with associative multiplication $n \times m$, (left and right) multiplicative unit I , $I \times n = n \times I = n$, addition $n + m = p \in F$ and additive unit 0 , $0 + n = n + 0 = n$, $\forall n, m \in F$.

The achievement of the modern number theory required contributions from the best scientific minds in history, including Gauss, Legendre, Jacobi, Cauchy, Lebesgue, Diriclet, Hamilton, Cayley, and many others.

A major historical effort was dedicated to the *classification of all possible numbers*, that is, all possible sets verifying the axioms of a numerical field. By the middle of the 20th century, it was universally believed in mathematics that the classification of all ordinary numbers (again, those with characteristic zero) had been achieved with the results that *all possible ordinary numbers are given by real numbers, complex numbers and quaternionic numbers*. Octonions do not qualify as numbers because they violate the associativity of the multiplication $(m \times n) \times p = m \times (n \times p)$.

As part of his Ph.D. in theoretical physics in the late 1960s at the University of Torino, Italy, Santilli set up his research goal of achieving a generalization-covering of quantum mechanics for which, to avoid the illusion of a real generalization, *he needed numbers more general than those used in quantum mechanics*, such as the real and complex numbers.

The difficulty of Santilli’s task was that, on one side, very authoritative mathematicians claimed emphatically that all ordinary numbers verifying the axioms of a numerical field had been classified while, on the other side, Santilli needed new numbers verifying indeed said axioms to avoid physical inconsistencies identified later on.

With great scientific audacity, and based on the conviction that mathematics will never admit final formulations, Santilli ignored all authoritative claims and set himself up to review the foundations of number theory. His position at the Department of Mathematics of Harvard University proved to be instrumental, not because of any help by departmental colleagues, but because their skepticisms reinforced his determination.

In this way, Santilli first discovered that the axioms of a numerical field do not require that the multiplicative unit be necessarily the number $I = +1$ dating back to pre-biblical times but used in pure mathematics up to the 20th century,

since the left and right multiplicative unit can be an arbitrary positive-definite quantity $\hat{I} = 1/T > 0$ generally outside the original set $F(n, \times, I)$, provided that the multiplication is suitably re-defined in the form $n \hat{\times} m = n \times T \times m$, under which \hat{I} remains indeed the correct left and right unit, $\hat{I} \hat{\times} n = n \hat{\times} \hat{I} = n$ for all elements of the set.

Santilli then proved that, under the above assumptions for the multiplication and its unit while keeping the conventional addition and its unit, all axioms of a field were verified even when the new unit \hat{I} is not an element of the original field F , in which case the new numbers are written $\hat{n} = n \times \hat{I}$. We reach in this way new numbers and fields for which Santilli suggested the name of *isonumbers and isofields* from the Greek meaning of preserving the original axioms. They are known today as **Santilli isoreal, isocomplex and isoquaternionic numbers, or generically isonumbers**, the new unit $\hat{I} = 1/T > 0$ is called **Santilli isounit**, its inverse T is called the **isotopic element**, and the new multiplication $a \hat{\times} b$ between two generic quantities a, b is called **isomultiplication**. The new sets \hat{F} are called **Santilli isofields** and are generally written in the form

$$\begin{aligned} \hat{F}(\hat{n}, \hat{\times}, \hat{I}) : \hat{I} = 1/T > 0, \hat{n} = n \times \hat{I}, \\ \hat{n} \hat{\times} \hat{m} = (n \times \hat{I}) \times T \times (m \times \hat{I}) = (n \times m) \times \hat{I}, \end{aligned} \tag{2.1}$$

$$\hat{F}(\hat{n}, \hat{\times}, \hat{I}) \approx F(n, \times, I). \tag{2.2}$$

In short, Santilli discovered a *new realization* of the conventional axioms of a field permitting new physical, chemical and other applications identified in subsequent chapters. When the new unit \hat{I} is outside the original set F , $\hat{F}(\hat{n}, \hat{\times}, \hat{I})$ is called an *isofield of the first kind*, and the numbers \hat{n} are called *isonumbers of the first kind*. When \hat{I} is an element of the original field F , that is, an ordinary number, $\hat{F}(\hat{n}, \hat{\times}, \hat{I})$ is called an *isofield of the second kind*, in which case the isonumbers of the second kind are often assumed to be the original numbers n without the multiplication by \hat{I} .

Santilli's isofields of the second kind are primarily used in mathematics, particularly to show the insufficiency of contemporary number theory, and its various notions such as that of prime (see the example below). Santilli's isofields of the first kind are of primary use for the new non-Hamiltonian classical and operator mechanics and their applications. Therefore, unless otherwise stated, in this book we shall always use Santilli's isofields of the first kind and simply refer them as "isofields."

Even though isofields are isomorphic to conventional fields, as indicated by their very name and Eq. (2.2), their differences are by far nontrivial, and their scientific implications beyond our imagination at this time. For instance, for the general isofields (of the first kind) we have expressions of the type

$$\hat{I} = 3 : 2 \hat{\times} 3 = 18; 4 = \text{prime number}. \tag{2.3}$$

These results signaled one of the biggest mathematical discoveries of the 20th century because it gave rise to momentous advances in physics, chemistry, biology and other quantitative sciences reviewed in the subsequent chapters.

Quite symptomatically, Santilli published for the first time his isonumbers in his two historical papers of 1985 [58, 59] on the isotopies of Lie's theory, particularly for the structural lifting of the fundamental symmetry of physics, the rotational symmetry that, in turn, is the basis for his lifting of Galilei's and Einstein's relativities. A mathematically rigorous presentation of isonumbers and isofields was then given in the 1993 paper [79]. A comprehensive study was then presented in monograph [12]. Numerous independent papers and books have been written on Santilli isonumbers and isofields (see the General Bibliography). We here merely quote monograph [187] written in 2001 by the Chinese mathematician Chun-Xuan Jiang that remains a significant general study in the field to this day. A readable presentation of Santilli's isonumbers in Italian is given by paper [202].

2.2.B *Discovery of genonumbers (1993)*

Despite the dimension and implications of the preceding discovery, Santilli remained dissatisfied because his main objective was to reach a structural generalization of quantum mechanics suitable for the representation of energy releasing processes, such as nuclear fusions, that are irreversible over time (that is, the time reversal images violate causality laws). Isonumbers could not allow such a generalization because they have no "time arrow."

Hence, Santilli went back to work and re-examined the foundations of his own isotopic number theory. He discovered in this way that, in addition not to require the value $I = +1$ for the multiplicative unit, the axioms of a field do not require that the unit for the multiplication to the right be equal to the unit for then multiplication to the left, provided that all multiplications are correspondently ordered to the right and to the left, respectively.

This discovery gave rise to a broader class of new numbers (again with characteristic zero, the sole known to have physical applications at this writing), also verifying the axioms of a field, called by Santilli *genonumbers* in the Greek meaning that they induce a new structure. The new numbers are known today as *Santilli's genoreal, genocomplex and genoquaternionic numbers to the right and to the left or, generically, as genonumbers.*

By using the symbols I^f and $n \times^f m$ for the genounit and genomultiplication to the right (physically interpreted as forward in time) and the symbols ${}^b I$ and $n {}^b \times m$ for the genounit and genomultiplication to the left, (physically interpreted

as backward in time) we can write the genofields in the form

$$\begin{aligned} F^f(n^f, \times^f, I^f) : I^f &= 1/S, \quad n^f = n \times I^f, \\ n^f \times^f m^f &= n^f \times S \times m^f = (n \times m) \times I^f, \end{aligned} \quad (2.4)$$

$$\begin{aligned} {}^bF({}^bn, {}^b\times, {}^bI) : {}^bI &= 1/R, \quad {}^bn = {}^bI \times n, \\ {}^bn \ {}^b\times \ {}^bm &= {}^bn \times R \times {}^bm = {}^bI \times (n \times m), \end{aligned} \quad (2.5)$$

$$I^f = ({}^bI)^c, \quad (2.6)$$

where c is a conjugation depending on the desired application (such as Hermitean conjugation, complex conjugation, inverse, transpose, etc.) needed for the interconnection between the right and left genofields.

Again, genofields are isomorphic to conventional fields by conception and construction. Nevertheless, the implications are by far nontrivial. For instance, by using the inverse for the conjugation c , a generic realization of $F^f(n^f, \times^f, I^f)$ and ${}^bF({}^bn, {}^b\times, {}^bI)$ is given by

$$I^f = 3, \quad {}^bI = 1/3, \quad 2 \times^f 3 = 18, \quad 2 \ {}^b\times \ 3 = 2, \quad (2.7)$$

namely, not only the product of 2 times 3 does not yield the usual number 6, but the product to the right is different than that to the left, all in a way fully compatible with the axioms of a numerical field.

This discovery carries scientific implications greater than those originating from isonumbers, because genonumbers have permitted the construction of mathematically rigorous methods for the invariant treatment of irreversibility, including the study of *new* energies, that are not treatable with the mathematics of the 20th century, because the latter has no “time arrow”. In fact, *Santilli genotheories represent irreversibility via the most basic mathematical quantity, the unit, with the physical interpretation that genounits and genomultiplication to the right (left) represent motion forward (backward) in time.*

Santilli presented the discovery of genonumbers in his historical mathematical paper of 1993 [79] and applied the new numbers in his monographs [12, 14]. A readable presentation of Santilli’s genonumbers in Italian is given by paper [203].

2.2.C Discovery of hypernumbers (1994)

Despite the above momentous discoveries, Santilli continued to remain dissatisfied because, as he stated in his works and correspondence, *I cannot accept the idea that the DNA code can be understood with genonumbers because, even though they do represent the irreversibility of biological processes, they cannot possibly represent how two atoms of a DNA can produce an entire organ with a very large number of constituents.*

In this way, the genonumbers were extended to yet new numbers today known as **Santilli's hyperreal, hypercomplex and hyperquaternionic numbers to the right and to the left, or generically as hypernumbers** that are *multivalued*, namely, not only the units and products to the right and to the left are different, but the hyperunit has an ordered set of values and, consequently, the multiplication yields an ordered set of results. For instance, the hyper-lifting of example (2.7) would yield expressions of the type

$$\begin{aligned} I^f &= \{3, 1/2, 1/3, \dots\}, 2 \times^f 3 = \{18, 32, \dots\}, 2 \\ {}^b I &= (I^f)^{-1} = \{1/3, 2, 3, \dots\}, {}^b \times 3 = \{2, 12, 18, \dots\}. \end{aligned} \quad (2.8)$$

It should be indicated that Santilli's hypernumbers are different than those belonging to hyperstructures because the former use conventional operations while the latter use abstract operations. Also, Santilli's hypernumbers verify all axioms of a field, while conventional hyperstructures do not generally admit any unit at all, thus not being generally formulated over a field, with consequential severe restrictions in applications.

Santilli published his hypernumbers for the first time in monograph [12] and then in mathematical memoir [93] with applications to biology presented in subsequent monograph [16]. A recent mathematical presentation of hypernumbers, including its formulation via hyperstructural methods, can be found in Chapter 5 of monograph [22].

2.2.D *Discovery of isodual numbers (1993)*

Despite all the above discoveries, each being quite significant, Santilli remained dissatisfied because, as he puts it in his works and correspondence: *When I look at the stars, I feel very frustrated as a physicist for my complete inability to study whether a far-away star or quasar is made up of matter or of antimatter.*

As indicated in Section 1.4, mathematical and physical methods of the 20th century were insufficient to allow any consistent classical description of antimatter. The new iso-, geno- and hyper-numbers were insufficient to reach the needed classical description of antimatter precisely because of their isomorphism to conventional numbers. In fact, charge conjugation is an anti-automorphism. Hence, a classical representation of antimatter admitting an operator image compatible with charge conjugation needs a mathematics that is anti-homomorphic or, better, anti-isomorphic to the conventional mathematics, as well as to its iso-, geno-, and hyper-liftings.

When at the Department of Mathematics of Harvard University, he conducted in the early 1980s a comprehensive search in the Cantabridgian mathematics libraries and concluded that the mathematics needed for a classical representation of antimatter did not exist in the form needed by physicists, such as to yield

under quantization an image equivalent to charge conjugation. Consequently, the needed new mathematics had to be built.

A day in February 1982 Santilli invited one of his mathematics colleagues to visit the mathematics library (located in the ground floor of Harvard's Science Center) and suggested him to select any desired volume by opening it at any desired page. He would prove that the mathematics in that arbitrary volume in that arbitrary page would *not* allow a physically consistent classical representation of antimatter. He was indeed right.

As a physicist, Santilli was forced, again, to study yet new mathematics and, for that scope, he was forced to study yet new numbers. In this way, he discovered that *the axioms of a numerical field admit negative units and the resulting fields are anti-isomorphic to conventional fields as desired*. More generally he introduced a new map he called *isoduality* (denoted with an upper index d) consisting of an anti-Hermitian operation given for an arbitrary quantity $Q(n, \dots)$ by

$$Q^d(n^d, \dots) = -Q^\dagger(-n^\dagger, \dots), \quad (2.9)$$

provided that the above map is applied to the totality of the elements of a given theory and all its operations. This gave rise to: **Santilli's isodual conventional, iso-, geno- and hyper-numbers**; negative definite units called **isodual conventional, iso-, geno-, and hyper-units**; and corresponding multiplications called **isodual conventional, iso-, geno-, and hyper-multiplications**.

As the simplest possible illustration, consider the conventional field $F(n, \times, I)$. Then, Santilli isodual field is given by

$$F^d(n^d, \times^d, I^d): I^d = -I, \quad n^d = -n^\dagger, \quad (n \times m)^\dagger = -(m^\dagger \times n^\dagger). \quad (2.10)$$

The isoduals of iso-, geno- and hyper-numbers can be similarly constructed via isoduality (2.9). Even though seemingly trivial, isodual numbers have their own rather deep implications requiring attention to prevent inconsistencies. For instance, the statement of having +1,000 dollars in the bank, in reality means for isodual numbers that the account is 1,000 dollars in the red because the number +1,000 is now referred to the basic unit -1 , the isodual norm of $-1,000$ is negative, etc.

To illustrate the mathematical novelty, we can report the following episode quoted by Santilli in footnotes of some of his books. In June 1996, Santilli and his wife Carla went to Palermo, Sicily, to pay their tribute to the *Circolo Matematico Palermo* for the publication of a special issue of its famous mathematics journal entirely dedicated to Santilli's isotopies. During that occasion, as a gesture of appreciation, the Editor in Chief of the journal, Prof. P. Vetro, found a 20 minutes opening at a mathematics conference going on in Palermo at that time and suggested Santilli to present there his new mathematics just appeared in the Rendiconti.

Santilli accepted the offer and elected to present his recently discovered isodual number theory and related mathematics by initiated his lecture with the projection in the big screen of a transparency with only the number “-1” in it and the indication that he assumed that quantity as the basic unit of his mathematics. At that view and statement, the audience went into great agitation with numerous questions from all sides, often repeated various times, to such a disarray that 20 minutes passed without Santilli being able to present any additional transparency.

Mathematicians are accustomed to write structures in an abstract, realization-free form. For this purpose Santilli suggests the use of the *conventional* symbol $F(n, \times, I)$ for the abstract unification of *all* his new numbers, provided one has a knowledge of all possible realizations, not only of the unit, but also of the related multiplications.

The above abstract unification would cause serious problems if used in physics because, e.g., it could cause the inadvertent mixing of particles and antiparticles. This is the reason that in physics it is much better to have different specific formulations for fields, isofields, genofields, hyperfields and their isoduals, since the identification of the assumed numbers and their unit identifies the level of treatment and related applications.

We cannot close this section without an indication of yet another mathematical discovery by Santilli given by iso-, geno-, hyper-fields and their isoduals when the related generalized unit *singular (or divergent)*, namely, are admitted to have a functional dependence with null (or infinite) value, an occurrence simply impossible for the 20th century mathematics, since fields are assumed to have the trivial unit +1. As we shall see in Chapter 3, this case is of particular physical relevance since $\lim \hat{I} \rightarrow 0$ represents *gravitational singularities*.

To the Foundation’s best knowledge, Santilli published for the first time his isodual numbers in historical mathematics paper [79] (see also monograph [19] for other references) and the monograph of 1993 [12]. A readable presentation of Santilli’s isodual numbers in Italian is given by article [204].

2.3 Discovery of Iso-, Geno-, Hyper-Differential Calculi, Functional Analysis and Their Isoduals (1996)

Santilli’s main scientific objective has been the study of Lagrange’s and Hamilton’s legacy (Section 1.1), namely, the study of contact non-Hamiltonian interactions at all possible levels, from Newtonian mechanics to second quantization. Besides the need for new numbers, Santilli faced another major technical obstacle, that of achieving the representation of all possible (well behaved) non-Hamiltonian forces via an action principle, because such a principle is necessary for quantization. As a matter of fact, the lack of achievement of any quantum formulation of non-Hamiltonian interactions during the 20th century was pre-

cisely due to the lack of any action principle for their classical representation, with consequential lack of any consistent method for their quantization.

Again, as a theoretical physicist, Santilli was forced to study pure mathematics as a condition to formulate consistent physical theories. After decades of trials and errors, Santilli recalled in the mid 1990s that Newton had to invent (with Leibnitz) the differential calculus before he was in a position to write his celebrated equations.

In this way, Santilli inspected the differential calculus and discovered that, contrary to a deeply rooted belief in pure mathematics for over about centuries, *the differential calculus is indeed dependent on the assumed basic unit*. Let r be the coordinate of a Newtonian particle and dr its differential. Assume the isotopic lifting of r into an isocoordinate $\hat{r} = r \times \hat{I}$, with isounit $\hat{I} = 1/T > 0$. In this case, Santilli proved that the *isodifferential* and *isoderivative* are given by

$$\hat{d}\hat{r} = T \times d(r \times \hat{I}), \quad \hat{d}/\hat{d}\hat{r} = \hat{I} \times d/dr. \quad (2.11)$$

If the isounit is independent from the local variable of the calculus, the differential is indeed independent from the local valuable because

$$\hat{I} = 1/T = \text{const}, \quad \hat{d}\hat{r} = T \times \hat{I} \times dr = dr, \quad \hat{d}/\hat{d}\hat{r} = d/dr, \quad (2.12)$$

thus recovering the indicated belief in pure mathematics. However, when the isounit depends on local variable, $\hat{I} = \hat{I}(r, \dots)$, the above simplification is no longer possible because we have for the differential

$$\hat{d}\hat{r} = T \times d[r \times \hat{I}(r, \dots)] = dr + T \times r \times d\hat{I}(r, \dots), \quad (2.13)$$

with a corresponding complex relation for the isoderivative. The geno- hyper- and isodual versions are evidently characterized by the use of the corresponding generalized units. Note that the geno-, and hyper-differential calculi for matter and their isoduals for antimatter are particularly important for the correct treatment of irreversible processes, as we shall see in Chapters 3, 4, 5.

The above studies marked the discovery of a structural generalization of the differential calculus that, as illustrated by the momentous implications outlined in this presentation, is indeed yet another mathematical discovery of clear historical proportions, today known as *Santilli's so-, geno-, hyper-differential calculi for matter and their isoduals for antimatter*.

It should be noted that the conventional differential calculus has only *one formulation*, the conventional one. By contrast, Santilli's generalized differential calculi have *two formulations* expressed in Eqs. (2.11)–(2.13) for the isotopic case, namely, a first formulation on isospaces over isofields, and a second one given by its *projection* on conventional spaces over conventional fields. Note that at the abstract representation-free level, isodifferential and conventional calculi coincide, and the same holds for the other calculi.

As we shall see in Section 3.12, Santilli's generalized differential calculi did permit the representation, for the first time, of all (well behaved) non-Hamiltonian Newtonian systems via a generalized action principle, thus permitting the identification, also for the first time, of their rigorous map into operator forms constituting the foundations of hadronic mechanics.

These various new calculi were first published in the 1995 *second edition* of monograph [12] and in subsequent works [93]. The *functional isoanalysis* was initiated by Santilli with the isotopies of basic functions such as exponential, logarithm, trigonometric and other functions, see Chapter 6 of monograph [12]. The construction of the new isoanalysis was continued by the physicist J.V. Kadeisvili, e.g. in papers [159, 160]. Additional work was done by the physicists A.K. Aringazin et al., see Appendix 4.B of monograph [14].

2.4 Discovery of Iso-, Geno-, Hyper-, Spaces and Their Isoduals (1983)

2.4.A Santilli's generalized spaces

As it is well known, all quantitative studies are defined on a representation space, such as the Euclidean Minkowski Riemannian, Finslerian or other (vector, metric or pseudo-metric) space that, in turn, is defined over a field of numbers. It is evident that the generalization of ordinary numbers produced a corresponding lifting of conventional spaces, today's known as *Santilli's iso-, geno, and hyper-Euclidean, Minkowskian, Riemannian, Finslerian and other spaces for matter and their isoduals for antimatter*.

The implications of these broader spaces are far reaching, as we shall see. Consider the conventional, $(3+1)$ -dimensional Minkowski space $M(r, m, I)$ with spacetime coordinates $r = (r^k)$, $k = 1, 2, 3, 4$, $r^4 = t$, metric $m = \text{Diag.}(1, 1, 1, -c^2)$ and invariant $r^2 = (r^i \times m_{ij} \times r^j) \times I$, where I is the unit of the Lorentz symmetry $SO(3,1)$, $I = \text{Diag.}(1, 1, 1, 1)$. Then, the isounit, isometric, and isoline element on **Minkowski-Santilli isospace** are given by

$$\begin{aligned} \widehat{M}(\widehat{r}, \widehat{m}, \widehat{I}) : \widehat{I} = 1/T &= \text{Diag.}(1/T_1^2, 1/T_2^2, 1/T_3^3, 1/T_4^4) \\ &= \text{Diag.}(n_1^2, n_2^2, n_3^2, n_4^2) > 0, \end{aligned} \quad (2.14)$$

$$\begin{aligned} \widehat{m} = T \times m &= (T_i^j \times m_{jk}) = \text{Diag.}(T_1^2, T_2^2, T_3^3, -c^2 \times T_4^4) \\ &= \text{Diag.}(1/n_1^2, 1/n_2^2, 1/n_3^2, -c^2/n_4^2), \end{aligned} \quad (2.15)$$

$$\begin{aligned} \widehat{r}^2 &= (\widehat{r}^i \widehat{\times} \widehat{m}_{ik} \widehat{\times} \widehat{r}^k) \times \widehat{I} \\ &= ((r^1)^2 \times T_1^2 + (r^2)^2 \times T_2^2 + (r^3)^2 \times T_3^3 - t^2 \times c^2 \times T_4^4) \times \widehat{I} \\ &= ((r^1)^2/n_1^2 + (r^2)^2/n_2^2 + (r^3)^2/n_3^2 - t^2 \times c^2/n_4^2) \times \widehat{I} \in \widehat{F}(\widehat{n}, \widehat{\times}, \widehat{I}), \end{aligned} \quad (2.16)$$

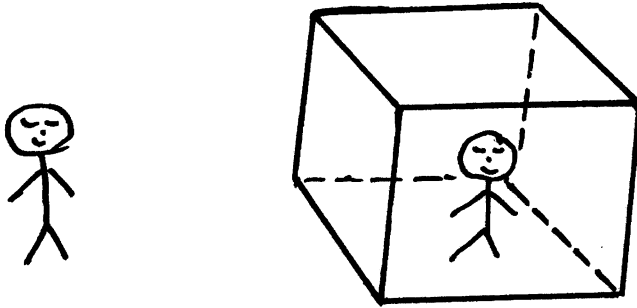

Figure 2.1. Santilli illustrates the far reaching implications of his isogeometries via the “isobox” consisting of a box inspected by two observers: an observer in the exterior verifying the conventional Minkowski spacetime, and an observer in the interior verifying the Minkowski-Santilli isospacetime. Santilli isonumbers and isospaces can be claimed to be understood if one understands that: the interior observer can be in the infinite future or past time with respect to the exterior observer; if the exterior observer sees a cube with 2-m side, the interior observer can see a room of dimension arbitrarily bigger or smaller compared to the exterior view; and if the exterior observer see a cube, the interior observer can see a cathedral. For explanations, interested readers should study the quoted literature.

where we have shown the most general possible, diagonal realization of Santilli’s isounit and its realization in physics via the so-called *characteristic quantities* n_k , $k = 1, 2, 3, 4$; $r^4 = t \times c$; and the notation $(r^k)^2$, $k = 1, 2, 3, 4$, denotes the square of r^k .

2.4.B Preliminary implications

The implications of the above discovery can only be qualified as historical, as shown in the rest of this presentation. We only mention the achievement, for the first time in scientific history via a metric, of:

1) The representation of *arbitrary speed of light* $C = c/n_4$, where n_4 is the familiar index of refraction, with values C smaller (bigger) than c for physical media of low (high) density;

2) The representation of the *actual dimension and shape* of particles via the space-component n_k^2 , $k = 1, 2, 3$ (normalized to the value 1 for the vacuum);

3) The representation of the *density* of the particles (or medium) considered via n_4^2 (also normalized to the value 1 for the vacuum);

4) The representation of the *inhomogeneity* of the physical medium considered via, e.g., a dependence of the characteristic quantities on the distance and other variables, $n_k = n_k(r, \dots)$;

5) The representation of the *anisotropy* of physical medium considered via a different value of the characteristic quantities.

A fundamental property of Santilli isospaces is that, by conception and construction, they are isomorphic to the original spaces for all positive-definite isounits. In fact, at the abstract, realization-free level, there is no difference between the conventional Minkowski space and the Minkowski-Santilli isospace, to such an extent that they can be expressed via the same symbols, only subjected to different interpretations. As we shall see in the subsequent chapters, this feature has very important implications for numerous aspects of scientific knowledge.

Another important property is that *Santilli's isospaces unify all possible spaces with the same dimension*. In fact, isoline element (2.16) clearly includes as particular cases the Minkowskian, Riemannian, Finslerian, non-Desarguesian and other line elements. Hence, $\widehat{M}(\widehat{r}, \widehat{m}, \widehat{I})$ unifies all possible spacetimes in (3.1)-dimensions. In the event the positive-definiteness of the isounit is relaxed, $\widehat{M}(\widehat{r}, \widehat{m}, \widehat{I})$ unifies all possible 4-dimensional spaces, including the Euclidean one, the differentiation between one space and the other being set by the unit.

As we shall see, the above unification alone has far reaching implications, such as the achievement of the first and only known, axiomatically consistent grand unification of electroweak and gravitational interactions that had escaped the best minds of the 20th century, including Albert Einstein.

Santilli's geno- and hyper spaces have implications perhaps more intriguing than those of the isospaces, because the former provide the first known geometric representation of irreversibility by embedding the direction of time in the geno- and hyper-metric itself, while the new spaces remain isomorphic to the original space even though, quite remarkably, the geno- and hyper-metrics are not necessarily symmetric.

Isospaces were first presented in two historical papers of 1983 on the structural generalization of the Minkowski space, the Lorentz symmetry and special relativity, with classical representation in paper [56] and operator counterpart [57]. A more detailed mathematical treatment via the isotopies of the Euclidean space was presented in two papers of 1985 [58, 59].

In reality Santilli wrote first the latter two papers on the iso-Euclidean space and then wrote the paper on the isotopies of Minkowski space. Unfortunately the former ended up being published two years following the publication of the latter due to incredible editorial obstructions Santilli felt obliged to report in the first 1985 paper.

Iso-, geno- and hyper-spaces for matter and their isoduals for antimatter were systematically presented in the historical memoir published by the Rendiconti in 1996 [93], with the initiation of their topology. Comprehensive studies were then published in Santilli's various books, including [12, 14]. Systematic mathematical studies on the new spaces and the the resulting new topology were conducted in monograph [186] among various others studies (see the general bibliography).

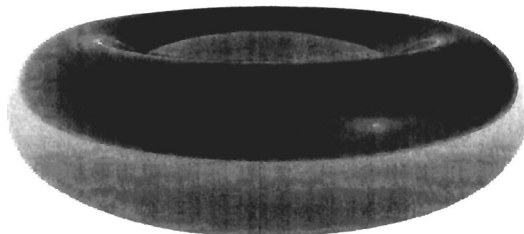

Figure 2.2. Santilli's illustration of his *geometrical locomotion* consisting of a purely mathematical model of a spaceship that A) can travel arbitrary distances, B) at arbitrary speeds and C) without any fuel tank, thus providing the first known mathematical model for a spaceship capable of reaching the stars. The absence of fuel tanks is achieved by mechanisms tapping the extreme energies densities in the ether as a universal substratum characterizing and propagating electromagnetic waves as well as particles (see Chapter 1 on Santilli's conception of the ether and Chapter 6 on the stars tapping energy from the ether to synthesize the neutron from the hydrogen atom). Arbitrarily speeds (that have to be immensely bigger than the speed of light in vacuum for practical travels to the stars) are achieved by the very tapping of energy from the ether that causes non-Newtonian forces without potential energies, thus being structurally beyond special relativity. Finally, arbitrary distances, including instantaneous accelerations and discontinuous trajectories, are achieved by the mechanism inherent in Santilli's isotopies, that of local changes of the units, therefore of distances, under which the spaceship is generally at rest and the environment is changing. But alterations of the space geometry cause inevitable alterations of time. Hence, for the spaceship to control its position in both space and time, there is the additional need of using negative energies (isolocomotion with both positive and negative energies). This suggests the ether as being characterized by a superposition of extremely large values of positive and negative energies coexisting with each other, thus resulting in the conventional vacuum, because defined in different spaces. In turn, the model provides a first concrete illustration of hyperstructures, one with two times, t and $t^d = -1$ and two space coordinates r and $r^d = -r$ which is precisely a two-valued hyper-isogeometry.

2.4.C Iso-, geno-, hyper-topologies and their isoduals

The central mathematical tools of 20th century quantitative sciences have been the conventional differential calculus and topology which tools, being strictly local-differential, are the ultimate reason for the abstraction of particles as dimensionless points moving in empty space (conditions characterizing the *exterior dynamical problem in vacuum*) and related dramatic limitations, such as those originating from Theorem 1.1.

Since the initiation of his research in the late 1960s, Santilli's primary objective has been the study of extended, nonspherical and deformable particles in condi-

tions of partial or complete mutual penetration (Figures 1.3, 1.4) or for extended particles moving within a physical medium (conditions characterizing the *interior dynamical problem within physical media*).

It is evident that such a study could not be conducted in a consistent way without the prior lifting of the local-differential character of the 20th century mathematics into a suitable nonlocal-integral form. This problem occupied Santilli's mind for decades due to the lack of the new mathematics in the form needed for physical applications, that is, as a covering of conventional local-differential methods. Said covering character was needed to recover 20th century physics when particles exit physical media and return to move in vacuum. Following extensive search in Italian and American mathematics libraries, Santilli was unable to locate the indicated new mathematics in the needed covering form. Therefore, the new mathematics had to be built prior to any quantitative physical, chemical or biological study.

After decades of attempts, Santilli finally succeeded to lift the local-differential calculus in the covering nonlocal-integrodifferential form (Section 2.3) as needed for physical applications, by embedding all nonlocal-integral terms in the isounit $\hat{I}(t, r, p, \dots) > 0$ as in Eq. (2.11), so as to recover the conventional differential calculus as a trivial particular cases when $\hat{I} = I$ [92].

Being primarily interested in physical applications, Santilli contacted various mathematicians and suggested them to study the isotopy of the conventional topology, such as the isotopy the conventional *Euclidean topology* at the foundation of both the Galilean and special relativities and quantum mechanics. The mathematicians Gr. T. Tsagas (then Chairman of the Department of Mathematics of Aristotle University, Thessaloniki, Greece) and D. S. Sourlas (also from Greece) answered Santilli's call and initiated the construction of the proposed *isotopology* in the early 1990s [172].

However, these initial versions were formulated on a conventional field, thus preventing consistent applications to physics (due to the Theorems of Catastrophic Inconsistencies of Section 3.7). Consequently, Santilli addressed the problem in 1996 [71] and achieved the first known formulation of the isotopology on an isospace over an isofield for the characterization of matter interior problem, as well as its isodual for antimatter interior problem. In memoir [92], Santilli also proved the intrinsic capability of the isotopology to characterize extended, non-spherical and deformable particles via realizations of the isounit of type (2.14), thus completing the construction of the new mathematics needed for basic physical, chemical and biological advances.

Subsequently, comprehensive studies on the isotopology were conducted in early 2000s by the mathematicians R. M. Falcon Ganfornina and J. Nunez Valdes [186] of the Department of Mathematics of the University of Seville, Spain, who achieved the final form of the nonlocal-integrodifferential topology used by

Santilli in all applications for matter, and today known as the *Tsagas-Sourlas-Santilli-Ganformina-Valdes isotopology* or *TSSGN isotopology* for short (see also paper [188]).

The best and most comprehensive mathematical reference on the TSSGN isotopology, including a review and quotation of all preceding literature, is the monograph of 2001 by R. M. Falcon Ganformina and J. Nunez Valdes [186] that essentially reports the Ph. D. Thesis of the first author under the guidance of the second author. Ironically, during the defense of the Ph. D. Thesis, both the student and his teacher were attacked for apparent triviality of the results, because the covering isotopology can be expressed by putting a "hat" on all symbols of the conventional topology.

However, as indicated in the Foreword of this chapter, besides momentous mathematical advances, the new isotopology allows the extension of Einstein's axioms, from their point-like abstraction of particles moving in vacuum, to extended particles in conditions of total or partial mutual penetration, as occurring in the structure of hadrons, nuclei and stars, with consequential prediction and quantitative treatment of much needed new clean energies that are inconceivable with the old topology (Chapter 7).

The best known presentation of the *isodual TSSGN isotopology* for antimatter is that in Santilli's monograph [18] of 2006. A recent readable presentation of these new topologies for physicists is that available in monographs [19,20,21] of 2008.

At this writing (Springs 2009), only the TSSGN isotopology for matter and its isodual for antimatter are known, while their geno- and hyperformulations and related isoduals are unknown, although expected to be a natural extension of the indicated isotopology and its isodual. Their study by interested mathematicians is solicited and financially supported by the Santilli Foundation due to their dramatic implications, such as setting mathematical foundations for the first known rigorous connection between irreversible geno-mechanics and thermodynamics.

2.5 Discovery of Iso-, Geno-, Hyper-Symplectic Geometries and Their Isoduals (1996)

As it is well known, the symplectic geometry allows one of the most rigorous studies of classical Hamiltonian systems, as well as their quantization. Hence, Santilli could not escape a re-inspection of the symplectic geometry because his main physical objective was to represent the most general possible (sufficiently smooth) *non-Hamiltonian* systems.

Consider the conventional canonical symplectic structure on a cotangent bundle with local charts r and p on the reals, $\omega = dp \wedge dr$. It was easy for Santilli to formulate its isotopic covering on an isocotangent bundle by first showing that local isochart is given by $\hat{r} = r \times \hat{I}$, $\hat{p} = p \times \hat{I}^{-1}$ on the isoreals, with consequential

isocanonical two isoform

$$\widehat{\omega} = \widehat{d}\widehat{p} \wedge \widehat{d}\widehat{r}, \quad (2.17)$$

that, as one can see, coincides with the conventional canonical two-form for all constant isounits, but possesses otherwise dramatic differences with the conventional version because it does allow the desired representation of all well-behaved equations of motion with all possible potential and nonpotential forces.

These studies lead to what are today known as **Santilli's iso-, geno-, and hyper-symplectic geometries for matter and their isoduals for anti-matter**. Their most salient feature is that of coinciding with the conventional symplectic geometry at the abstract level to such an extent that Santilli insists in writing the equations for his covering geometries via the symbols of the conventional geometry, and merely subjects them to a broader interpretation.

The above coverings of the symplectic geometry were first published in monograph [12] as well as in his mathematical memoir [93].

2.6 Isotopic Unification of Minkowskian, Riemannian, and other Geometries (1998)

A very special feature of Santilli's isotopies is that of unifying seemingly different structures into a covering form that enjoys the basic property of invariance. Following the achievement in 1983 of his iso-Minkowski spaces (Section 2.4), Santilli realized that there is no difference between his iso-Minkowski metric $\widehat{m}(r, \dots)$ and a conventional Riemannian metric $g(r)$ or a velocity-dependent metric $g(r, v, \dots)$ since the explicit form of the characteristic quantities n_i is unrestricted by the isotopies (only their positive-definite character is requested for isotopies).

But Santilli knew at that time (early 1990s) that the iso-Minkowski spaces are isomorphic to the *conventional* space. Hence, his isotopic methods offered a unique possibility of an isotopic unification of the Minkowskian, Riemannian and Finslerian geometries, with far reaching implications studied in the subsequent chapters, such as the first axiomatically consistent grand unification of electroweak and gravitational interactions reviewed in the physics chapters.

In this way, Santilli achieved a new geometry on isospaces over isofields, today called **Minkowski-Santilli isogeometry** equipped with all the machinery of the Riemannian geometry (such as covariant derivative, Christoffel's symbols, etc.), that does unify the Minkowskian and Riemannian geometries, while admitting both as particular cases depending on the selected isounit.

This additional historical achievement was published by Santilli in various works, with primary presentation in memoir [104].

Numerous papers then appeared showing the so called "direct universality" of the Minkowski-Santilli isogeometry, that is, the capability of admitting as particular cases all infinitely possible (non singular) geometries on a $(3 + 1)$ -

dimensional space (universality), directly in the selected coordinates without any need for the transformation theory (direct universality). Among numerous papers on this aspect, we quote paper [171].

2.7 Lie-Isotopic Covering of Lie's Theory and Its Isodual (1978)

As it is well known, Lie's theory has been the fundamental mathematical tool of the 20th century quantitative sciences, thus having been the subject of vast attention and having achieved a vast diversifications into various branches, such as:

1) The *universal enveloping associative algebra* U over a field $F(n, \times, I)$ as a vector space whose elements are: the unit matrix $I = \text{Diag.}(1, 1, \dots, 1)$ with the dimension of the selected representation; the N (Hermitean) generators G_k , $k = 1, 2, 3, \dots, N$, with conventional associative products $G_i \times G_j$; and the infinite-dimensional basis characterized by the Poincaré-Birkhoff-Witt theorem via the ordered monomials

$$U : I, G_k, G_i \times G_j, i \leq j, G_i \times G_j \times G_k, i \leq j \leq k, \dots, \quad (2.18)$$

which basis is necessary for the definition of exponentiation $W = \exp(G \times w \times i)$, where $w \in F$, and other operations on U ;

2) The N -dimensional *Lie algebra* L which is the antisymmetric algebra U^- attached to U with *Lie product* and closure relations

$$L : [G_i, G_j] = G_i \times G_j - G_j \times G_i = C_{ij}^k \times G_k, \quad (2.19)$$

where the C s are the *structure constants* of L ;

3) The *Lie group* g whose realization most important in physics is that of *Lie's transformation groups* of a quantity $Q(w)$ that can be written in the following finite and related infinitesimal forms

$$g : Q(w) = W(w) \times Q(0) \times W(w)^\dagger \\ = \exp(G \times w \times i) \times Q(0) \times \exp(-i \times w \times G), \quad (2.20)$$

$$i \times dQ/dw = [Q, G] = Q \times G - G \times Q; \quad (2.21)$$

plus the *representation theory* generally constructed either on a *right acting module* u or, equivalently for Lie's theory, the *left acting module* $-u$.

It should be recalled that Lie's theory characterizes the fundamental dynamical equations of quantum mechanics, those of the time evolution via Eqs. (2.21) with w representing time t . Lie's theory also characterizes all fundamental symmetries in physics, such as the Lorentz and Poincaré symmetries at the foundation of special relativity, the $SU(3)$ symmetry for the classification of particles, etc.

Immediately following the study of Lie's theory during his graduate studies in physics in Torino, Italy, in the late 1960s, Santilli realized the excessive limitations of the theory, since Lie's theory solely applies for systems that are linear, local-differential and Hamiltonian (canonical at the classical level and unitary at the operator level), while the systems of the real world are generally nonlinear, nonlocal-integral and admit both Hamiltonian and non-Hamiltonian interactions. Hence, Santilli set in the late 1960s his goal to reach a structural generalization of Lie's theory applicable to a broader class of systems.

As a main result of his Ph.D. thesis, Santilli published in 1967 the first formulation in physics records of the *Lie-admissible covering of Lie's theory* studied in the next section that is ideally suited for rigorous formulations of irreversibility as we shall see in Chapter 3.

However, Santilli knew of the existence in nature of systems that are non-Hamiltonian, yet verify all conventional conservation laws (see Section 3.12), whose characterization requires an algebra which is a covering of Lie algebras (to exit from the class of Hamiltonian equivalence), yet it is characterized by an antisymmetric product (to characterize the conservation of total quantities). Lie-admissible algebras do not verify this requirement because, as we shall see in the next section, their product is neither totally antisymmetric nor totally symmetric, thus being particularly suited to represent time rate of variations of physical quantities, but not their conservation.

Following decades of silent research, Santilli released in 1978 a particular case of the broader Lie-admissible theory consisting of an isotopic (axiom-preserving) generalization (he called *lifting*) of all branches of Lie's theory, today known as the **Lie-Santilli isothory**, that constitutes one of the biggest mathematical and physical discoveries of the 20th century, not only because of fundamental mathematical novelty, but also because of its predictable far reaching implications for all quantitative sciences, as shown in Chapters 3, 4, 5.

Santilli's Lie-isotopic theory is based on *all* preceding mathematical discoveries, that is, its correct formulation requires isofields, isospaces, isodifferential calculus, isofunctional analysis, etc., to such an extent that the lack of isotopic lifting of only *one* methodological aspect of Lie's theory causes catastrophic inconsistencies (lack of invariance of the theory under its own action, etc.). In fact, the mixing of Lie and Lie-Santilli's methods would be like formulating the conventional Lie's theory on Santilli's isofields, resulting in evident inconsistencies.

Under the above understanding, the presentation of Santilli's Lie-isotopic theory is now (following its discovery) rather elementary and its main branches can be summarily presented for applied mathematicians as follows:

1) The *universal enveloping isoassociative algebra* \widehat{U} over an isofield $\widehat{F}(\widehat{n}, \widehat{\times}, \widehat{I})$ as a vector space whose element are: the isounit $\widehat{I} = 1/T > 0$ (where the positive-definiteness is assumed to preserve Lie's axioms and the dimension is that of the

used isorepresentation); the same (Hermitean) generators $G_k, k = 1, 2, 3, \dots, N$, of Lie's theory with *isoassociative product* and related isounit

$$G_i \widehat{\times} G_j = G_i \times T \times G_j, \tag{2.22}$$

$$\widehat{I} \widehat{\times} \widehat{G} = \widehat{G} \widehat{\times} \widehat{I} = \widehat{G}, \forall G \in \widehat{U}, \tag{2.23}$$

and the infinite dimensional isobasis characterized by the *Poincaré-Birkhoff-Witt-Santilli isothorem* with ordered *isomonomials*

$$\widehat{U} : \widehat{I}, G_k, G_i \widehat{\times} G_j, i \leq j, G_i \widehat{\times} G_j \widehat{\times} G_k, i \leq j \leq k, \dots \tag{2.24}$$

permitting the definition of *isoexponentiation*

$$\begin{aligned} \widehat{W}(\widehat{w}) &= \widehat{I} + \widehat{i} \widehat{\times} \widehat{w} \widehat{\times} G / 1! + \dots = [\exp(G \times T \times w \times i)] \times \widehat{I} \\ &= \widehat{I} \times [\exp(i \times w \times T \times G)] \end{aligned} \tag{2.25}$$

and other operations on \widehat{U} ;

2) The N -dimensional *Lie-Santilli isoalgebra* \widehat{L} which is the antisymmetric isoalgebra \widehat{U}^- attached to \widehat{U} with Lie-Santilli isoproduct and closure relations

$$\widehat{L} : [G_i \widehat{\times} G_j] = G_i \widehat{\times} G_j - G_j \widehat{\times} G_i = G_i \times T \times G_j - G_j \times T \times G_i = \widehat{C}_{ij}^k \widehat{\times} G_k, \tag{2.26}$$

where \widehat{C}_{ij}^k characterizes the *isostructure isofunctions* of LC_{ij}^k with constant particularizations;

3) The *Lie-Santilli isogroups* \widehat{g} whose realization most important in physics is that of *Santilli's isotransformation isogroups* of a generic quantity $\widehat{Q}(\widehat{w})$ on \widehat{U} over \widehat{F} that can be written in the following finite and infinitesimal forms each in a dual way, the formulation on \widehat{U} over \widehat{F} and its projection on U over F

$$\begin{aligned} \widehat{g} : \widehat{Q}(\widehat{w}) &= \widehat{W}(\widehat{w}) \widehat{\times} \widehat{Q}(\widehat{0}) \widehat{\times} \widehat{W}(\widehat{w})^\dagger \\ &= \exp(G \times T \times w \times i) \times Q(0) \times \exp(-i \times w \times T \times G), \end{aligned} \tag{2.27}$$

$$\widehat{i} \widehat{\times} d\widehat{Q} / d\widehat{w} = [Q, G] = Q \times T \times G - G \times T \times Q; \tag{2.28}$$

plus the *isorepresentation isothory* generally constructed either on a *right acting isomodule* \widehat{u} or, equivalently, the *left acting isomodule* $-\widehat{u}$.

As one can see, Santilli's isothory causes the emergence of a generally nonlinear, nonlocal and non-Hamiltonian operator T in the *exponent* of the isotransformations, as well as in the broader isobrackets of the infinitesimal transforms, thus permitting indeed the originally desired extension of Lie's theory to nonlinear, nonlocal and non-Hamiltonian systems with far reaching implications indicated in the subsequent chapters.

Remarkably, Santilli proved the “direct universality” of his isothory for all well behaved nonlinear, nonlocal and non-Hamiltonian systems via the following:

THEOREM 2.7.1: All sufficiently smooth nonlinear, nonlocal-integral and non-Hamiltonian systems (whether classical noncanonical or operator nonunitary) on conventional spaces over a conventional field always admit an isounit for which they can be identically reformulated on isospaces over isofields where they are isolinear, isolocal and isocanonical or isounitary (verify the axioms of linearity, locality and Hamiltonian character on isospaces over isofields).

The reconstruction of linearity, locality and canonicity or unitarity is merely done by embedding all nonlinear, nonlocal and non-Hamiltonian terms in the isounit. This important property is the conceptual essence of Santilli’s isothory in both its mathematical meaning and physical applications. Recall that Lie’s theory is strictly linear, local-differential and Hamiltonian on conventional spaces over ordinary fields. In the event Santilli had not preserved at the covering level these fundamental properties, his theory could not be called an “isotopy” (axiom-preserving) lifting of Lie’s theory. In turn, the loss of the isotopic character would have caused serious physical problems.

Recall from the preceding sections that the isotopies have the important capabilities of unifying seemingly different mathematical structures. In the original proposal of 1978, Santilli proved that the Lie-isotopic algebra $O^*(3)$ unifies all simple (compact and non-compact) Lie-algebra of dimensions three, and then formulated the following:

CONJECTURE 2.7.1: All simple Lie-algebras of dimension N can be unified into one single simple Lie-isotopic algebra of the same dimension.

The mathematician Gr. Tsagas proved the above conjecture to be correct for all simple Lie algebras with the exclusion of the exceptional algebras (see the reference below). *The Foundation is interested in funding the completion of the proof of Conjecture 2.7.1 by qualified mathematicians.*

The axiomatic unity of the conventional Lie theory and its isotopic covering is such that Santilli insists in presenting the latter with the same symbols of the former, only subjected to a broader realization, as it is the case for isonumbers, isospaces, isogeometries, etc.

As we shall see, the above property also differentiates Santilli’s studies from a variety of other attempts to generalize Lie’s theory, all known today to verify the *Theorems of Catastrophic Mathematical and Physical Inconsistencies* recalled in Section 3.9, precisely because of the latter theories are based on the broadening of Lie’s theory, on one side, combined with the preservation of the conventional mathematics, on the other side.

The above isotopic lifting of Lie's theory was constructed by Santilli for the sole treatment of *matter*. For the classical treatment of *antimatter* in such a way to achieve compatibility with the operator formulations, Santilli needed an anti-isomorphic image of the above Lie-isotopic theory that he constructed via his isodual map (2.9) applied to the *totality* of quantities and their operations of the Lie-isotopic theory. This resulted in *two* new coverings of Lie's theory today known as **Santilli isodual Lie theory and isodual Lie-isotopic theory**, that are not reviewed here for brevity.

The discovery of the isotopic covering of each branch of Lie's theory was published for the first time in 1978 when Santilli was at Harvard University under DOE support via two hundred pages historical memoir [43]. The theory was then expanded in the series of volumes [1, 2] published by the most prestigious scientific house of the time, Springer Verlag, in its most prestigious series of *Text and Monograph in Theoretical Physics*.

These original presentations were based on isospaces, but defined on conventional fields. Subsequently, Santilli discovered the lack of completion of this formulation and, following the availability of the isonumbers, reached a mathematically consistent formulation in various works, such as in the monograph [12, 14] that included a treatment of isodual Lie theory and isodual Lie-isotopic theory.

The discovery of the isodifferential calculus permitted Santilli to achieve the final formulation of his Lie-isotopic theory that was published in the second edition of 1995 of the above two volumes. A comprehensive presentation of the isodual Lie theory and the isodual Lie-isotopic theory is available in monograph [19]. Santilli's most recent presentation is available in monograph [22] with a treatment of the Lie, Lie-isotopic theories and their isoduals.

Due to its historical importance, the Lie-Santilli isothory has been the subject of numerous independent studies, among which we can quote review papers [176, 177] and monographs [165, 179, 186]. The proof of Conjecture 2.7.1 for all simple Lie algebra with the exclusion of the exceptional algebras can be found in paper [175].

For a comprehensive list of all contributions on the Lie-Santilli isothory, the interested scholar is suggested to consult the General Bibliography on Santilli Discoveries.

2.8 Lie-Admissible Covering of the Lie-Isotopic Theory And Its Isodual (1967)

2.8.A The birth of Lie-admissibility

Remarkably, Santilli remained dissatisfied with his own Lie-isotopic theory for *physical* and not mathematical reasons. Due to its structure and underlying

topology, Lie's theory is ideally suited to represent a closed-isolated system of particles that, being necessarily abstracted as point-like, have no collisions, thus characterizing a Hamiltonian system (namely, a system entirely described by the Hamiltonian). This is typically the case for the atomic structure and other systems. In these cases, the antisymmetric character of Lie's brackets $[A, B] = A \times B - B \times A = -[B, A]$ permits the representation of the conservation of the total quantities (represented in physics by the generators), as it is the case for the Hamiltonian

$$i \times dH/dt = [H, H] = H \times H - H \times H = 0. \quad (2.29)$$

Santilli's Lie-isotopic theory does enlarge the class of represented systems into particles that are extended (see Section 3.12), thus experiencing collisions with both Hamiltonian and non-Hamiltonian interactions, yet the systems are isolated from the rest of the universe, thus also verifying total conservation laws. This is the case at a classical level of the structure of a planet such as Jupiter, or a nucleus at the operator level. Since Santilli's isotopic product is also antisymmetric, $[A \hat{,} B] = A \times T \times B - B \times T \times A = -[B \hat{,} A]$, it allows total conservation laws, such as

$$i \times dH/dt = [H \hat{,} H] = H \times T \times H - H \times T \times H = 0, \quad (2.30)$$

where H is the conventional Hamiltonian and T represent all contact non-Hamiltonian interactions and effects (see Chapter 3).

Hence, the Lie-isotopic theory cannot be a final theory because the systems of the physical reality are, in general, open, nonconservative and irreversible, as it is the case for a constituent of Jupiter or a proton in the core of a star when considering the rest of the system as external.

Santilli then searched for a covering of Lie's isotopic theory with a product (A, B) that is neither totally antisymmetry nor totally symmetric, $(A, B) \neq \pm (B, A)$ as a condition to characterize time-rate-of-variations $f(t)$ of physical quantities,

$$i \times dH/dt = (H, H) = f(t) \neq 0, \quad (2.31)$$

since conservation laws are a trivial particular case.

While doing his Ph.D. studies at the University of Torino, Italy, in the late 1960s, Santilli conducted for years a comprehensive search at European mathematical libraries to identify the desired covering of Lie's theory. He was finally rewarded with the identification of a paper of 1947 by the American mathematician A.A. Albert who introduced, without any specific realization or elaboration, the notion of *Lie-admissible algebras* as a (generally nonassociative) algebra U with abstract elements a, b, c, \dots and abstract (generally nonassociative) product ab such that the attached algebra U^- given by the same vector space as U but equipped with the product $[a, b] = ab - ba$, is Lie.

Albert also introduced the notion of *Jordan-admissible algebra* as the same algebras U when such that the attached algebra U^+ with product $\{a, b\} = ab + ba$ is Jordan. Following additional extensive library search, Santilli could only identify in European mathematics libraries a second note in the field by M. Tomber, although without realizations or elaborations.

Inspired by Albert's paper, Santilli published in 1967 the paper [32] on the embedding of Lie algebras in Lie-admissible algebras verifying central condition (2.31), where he presented for the first time a specific realization of Lie-admissible and Jordan-admissible algebras with product $(A, B) = p \times A \times B - q \times B \times A$ identified in more details in Section 3.8.

To understand the novelty of this paper (and others by Santilli written in 1967–1968 not quoted here for brevity), we recall that in 1967 Santilli moved from the University of Torino, Italy, to the University of Miami, Coral Gables, Florida, for a one year stay. During that time, he applied for a job to virtually all Departments of Physics in the U. S. A. by presenting with pride his discovery of Lie-admissible and Jordan-admissible algebras and their applications for the characterization of the time rate of variation of physical quantities. To his demise, no physicist in the U. S. A. knew the existence or meaning of these algebras at that time.

Numerous applications for a job at various U. S. Departments of Mathematics turned out also to be sterile because of the general lack of knowledge by mathematicians of the time of the algebras herein considered. In fact, the above 1967 paper was the very first on Lie-admissible and Jordan-admissible algebras in the physic literature and it was the mere *third* paper in the field in the mathematics literature, including the two preceding papers by Albert and Tomber duly quoted in the above listed reference.

In this way, Santilli understood that there was no possibility to secure an academic job in the USA with so advanced a research. He then turned his attention to orthodox lines of studies and soon got a position at Boston University. During the subsequent ten years, Santilli published excellent but fully aligned papers at Phys. Rev. MIT Annals of Physics and orthodox journals of that nature.

2.8.B *Santilli Lie-admissible theory*

It was only in 1978 that Santilli decided to return to his “first scientific love” and released his studies on Lie-admissible algebras in the historical 200 pages long memoir quoted in Section 2.7. He subsequently developed further these studies resulting in a covering of his Lie-isotopic theory today known as **Santilli's Lie-admissible theory (or genothory)**, that is based on the preceding discoveries of genofields, genospaces, genodifferential calculus, etc. and can be outlined via the following branches:

${}^b1^f$) An *enveloping genoassociative algebra to the right (forward)* U^f with ordered product to the right over the genofield to the right $F^f(n^f, \times^f, I^f)$ with elements given by: the genounit to the right $I^f = 1/S$; the generators G_k , $k = 1, 2, \dots, N$ (as for the original Lie algebra), ordered genoassociative products to the right and related genounit

$$I^f = 1/S, \quad G_i \times^f G_j = G_i \times S \times G_j, \quad (2.32)$$

$$I^f \times^f G_k = G_k \times^f I^f = G_k, \quad \forall G_k \in U^f; \quad (2.33)$$

the infinite-dimensional genobasis acting on a genomodule to the right u^r

$$U^f : I^f, G_k, G_i \times^f G_j, i \leq j, \quad G_i \times^f G_j \times^f G_k, i \leq j \leq k, \dots \quad (2.34)$$

and related *genoexponentiation to the right*

$$W^f(w^f) = I^f + i^f \times^f w^f G/1! + \dots = [\exp(G \times S \times w \times i)] \times I^f, \quad (2.35)$$

plus an *enveloping genoassociative algebra to the left (backward)* bU on the genofield to the left ${}^bF({}^bn, {}^b\times, {}^bI)$ with elements: the genounit to the left ${}^bI = 1/R$; the generators ${}_kG$ (ordered to the left), $k = 1, 2, \dots, N$, with genoproduct and genounit

$${}^bI = 1/R, \quad {}_iG \times^b {}_jG = {}_iG \times S \times {}_jG, \quad (2.36)$$

$${}^bI \times^b {}_kG = {}_kG \times^b {}^bI = {}_kG, \quad \forall {}_kG \in {}^bU \quad (2.37)$$

the infinite dimensional genobasis acting on a *genomodule to the left* bu (where now $u^b \neq \pm {}^lu$)

$${}^bU : {}^bI, {}_kG, {}_iG \times^b {}_jG, i \leq j, \quad {}_iG \times^b {}_jG \times^b {}_kG, i \leq j \leq k, \dots \quad (2.38)$$

genoexponentiation to the left

$${}^bW({}^bw) = {}^bI \times [\exp(i \times w \times R \times G)], \quad (2.39)$$

and subsidiary condition

$${}^bI = (I^f)^\dagger \quad (2.40)$$

that are important in physical applications, e.g., to connect consistently motions forward and backward in time. The combination of the two genoenvelopes ${}^bU \times U^f$ then acts on the *genobimodule* ${}^bu \times u^f$ which is the representation genospace of the theory;

${}^b2^f$) *Santilli's Lie-admissible algebras* ${}^bL^f$ as the bimodular algebra attached to ${}^bU \times U^f$ characterized by the new product and closure rules

$$\begin{aligned} {}^bL^f : ({}_iG, G_j) &= {}_iG \times^b {}_jG - G_j \times^f G_i \\ &= G_i \times R \times G_j - G_j \times S \times G_i = {}^bC_{ij}^{fk} \times G_k, \end{aligned} \quad (2.41)$$

where the last expression is the projection of the algebra in the space of the original Lie algebra. As one can see, the resulting new product, here generically written $(A, B) = A \times R \times B - B \times S \times A$, is indeed jointly Lie-admissible and Jordan admissible although in Santilli's isotopic sense because

$$[\widehat{A}, \widehat{B}] = (A, B) - (B, A) = A \times L \times B - B \times L \times A, \quad L = R + S, \quad (2.42)$$

$$\{\widehat{A}, \widehat{B}\} = (A, B) + (B, A) = A \times J \times B + B \times J \times A, \quad J = R - S; \quad (2.43)$$

${}^b3^f$) Santilli genotransformation groups ${}^b g^f$ characterized by the left and right genoexponentiations (here written for simplicity in the representation space of the original Lie algebra)

$${}^b g^f : W^f \times^f Q(0) \times^b W = \exp(G \times S \times t \times i) \times Q(0) \times \exp(-i \times t \times R \times G), \quad (2.44)$$

with infinitesimal version characterized precisely by Santilli Lie-admissible brackets in the following simplified form

$$i \times dQ/dw = (Q, G) = A \times R \times G - G \times S \times Q, \quad (2.45)$$

where G and w are the same generator and parameter as those of the attached Lie-isotopic algebra.

Unexpectedly, Santilli proved that his Lie-admissible covering of his Lie-isotopic theory is isomorphic to the Lie-isotopic and conventional Lie theory despite the lack of totally antisymmetric character of the product. This property was proved by noting that each of the two genoassociative algebras ${}^b U$ and U^f , when defined on the respective modules ${}^b u$ and u^f over the corresponding genofields ${}^b F$ and F^f are isomorphic to the conventional associative enveloping algebra U over F .

The understanding of this important mathematical property, rather crucial for quantitative representations of irreversibility, can be seen by noting that, when the two products $A \times R \times B$ and $B \times S \times A$ are considered with respect to the conventional unit I of Lie's theory, the two algebras with products $(A, B) = A \times R \times b - B \times S \times A$ and $[A, B] = A \times B - B \times A$ are manifestly non-isomorphic.

However, when the product $A \times R \times B$ is computed with respect to the genounit $I^f = 1/R$, the result is equivalent to that of the product $B \times S \times A$ represented with respect to the genounit ${}^b I = 1/S$, and both products are equivalent to the product $A \times B$ with respect to the unit I .

Santilli decomposed his Lie-admissible product into a totally antisymmetric and a totally symmetric forms,

$$(A, B) = [\widehat{A}, \widehat{B}] + \{\widehat{A}, \widehat{B}\} = (A \times Y \times B - B \times Y \times A) + (A \times Z \times B + B \times Z \times A), \quad R = Y + Z, \quad S = Y - Z, \quad (2.46)$$

and proved the following important

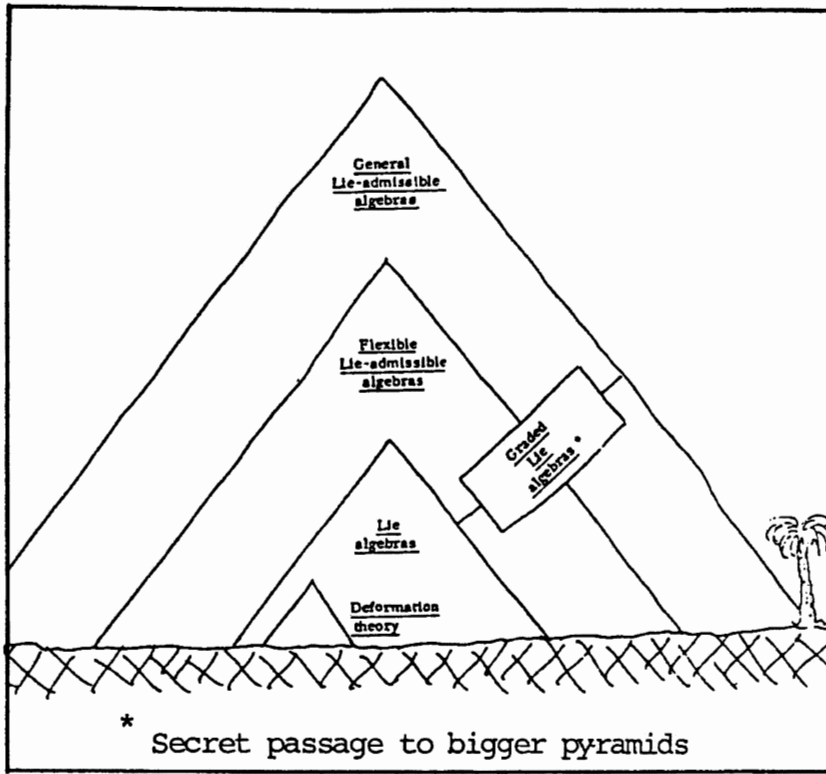

Figure 2.3. Another “vignette” presented by Santilli to his colleagues at the Lyman laboratory of physics of Harvard University at the initiation of his stay there in September 1978 under DOE support, illustrating the universality of Lie-admissible algebras because containing as particular cases all known or otherwise possible algebras. The study of Lie-admissible algebras encountered extreme opposition at Harvard University because of their consequential generalization of Einsteinian doctrines, quantum mechanics, quantum chromodynamics, and all that, as indeed achieved by hadronic mechanics thanks to Santilli’s resilience to academic vexations.

THEOREM 2.8.1: Lie-admissible algebras with product (A, B) are “directly universal,” in the sense of admitting as particular cases all possible algebras on a field of characteristic zero (universality) without use of the transformation theory (Direct universality).

In fact Santilli’s Lie-admissible algebras contain as particular cases all known or otherwise possible algebras with a bilinear composition law, such as: associative, flexible, alternative, Lie, Jordan, Lie-isotopic, Jordan-isotopic, supersymmetric and any other possible algebra.

The above presentation is solely intended for Lie-admissible treatment of *matter* in irreversible conditions. For the corresponding treatment of *antimatter* we have **Santilli's isodual Lie-admissible theory**, that can be constructed via the application of the isodual map (2.9) to the *totality* of the quantities and their operation of the Lie-admissible theory.

The Lie-admissible covering of the Lie-isotopic theory was presented in the historical 200 pages long memoir [43] quoted above, with physical applications presented in the joint memoir [44] submitting hadronic mechanics as a covering of quantum mechanics.

Santilli then developed further his Lie-admissible theory in two volumes [3, 4]. Additional presentations were made by Santilli in the two monographs [1, 2] published by Springer-Verlag in 1978 and 1982; a recent update is available in the 2008 monograph. Subsequently, Santilli wrote a comprehensive presentation of his Lie-admissible theory and its isodual in two monographs [12, 14].

A more recent presentation is available in the monograph [22], and the memoir [120] published by the Italian Physical Society where Santilli applies his Lie-admissible theory for the first and only known invariant representation of irreversibility for matter and, separately, for antimatter, originating at the most elementary level of nature, that of elementary particles and antiparticles.

The most active mathematician in the study of Santilli's Lie-admissible algebras has been H.C. Myung, e.g., with monographs [147, 153, 170].

Numerous mathematical works on Lie-admissibility can be located in General Bibliography on Santilli Discoveries.

2.8.C Santilli-Vougiouklis multi-valued hyper-Lie theory

Again remarkably for the depth of his self-criticisms, Santilli remained dissatisfied for his Lie-admissible covering of his Lie-isotopic theory because it was *single-valued*, namely, the forward or backward genounits had one single value, and the same was the case for products, spaces, and the remaining formalism.

in fact, by the early 1990s, Santilli has discovered spacetime has at least a *two-fold structure*, namely, one spacetime for the characterization of matter with conventional, isotopic or genotopic unit \hat{I} for the characterization of matter, and an anti-isomorphic spacetime for the characterization of antimatter with isodual isotopic, genotopic unit $\hat{I} = -\hat{I}^\dagger$.

According to experimental evidence, matter and antimatter coexist in our environment, as it is the case for the pair production in particle laboratories of an electron and a positron. However, their representation space, even though equally coexisting, are necessarily different from each other.

This lead Santilli in a rather natural way to the conception of *two-valued hyperstructures with a unit*, first proposed in monograph [12] in which *the basic unit is two-valued, i.e., it can assume the ordered set of values $\hat{I} = \{I, I^d\}$ with conse-*

quential two-valued multiplications and corresponding formulations, thus achieving a unified formulation of both matter and antimatter. The extension or an arbitrary ordered set of values was then rather natural. In this way, Santilli introduces the multivalued forward and backward hyperunits

$$\widehat{I}^>(t, x, v, \psi, \partial_x \dots) = \text{Diag.}(\widehat{I}_1^>, \widehat{I}_2^>, \widehat{I}_3^>) = \\ \text{Diag.} \left[(\widehat{I}_{11}^>, \widehat{I}_{12}^>, \dots, \widehat{I}_{1m}^>), (\widehat{I}_{21}^>, \widehat{I}_{22}^>, \dots, \widehat{I}_{2m}^>), (\widehat{I}_{31}^>, \widehat{I}_{32}^>, \dots, \widehat{I}_{3m}^>) \right], \quad (2.47a)$$

$$\widehat{I}^<(t, x, v, \psi, \dots) = \text{Diag.}(\widehat{I}_1^<, \widehat{I}_2^<, \widehat{I}_3^<) = \\ = \text{Diag.} \left[(\widehat{I}_{11}^<, \widehat{I}_{12}^<, \dots, \widehat{I}_{1m}^<), (\widehat{I}_{21}^<, \widehat{I}_{22}^<, \dots, \widehat{I}_{2m}^<), \right. \\ \left. (\widehat{I}_{31}^<, \widehat{I}_{32}^<, \dots, \widehat{I}_{3m}^<) \right], \quad (2.47b)$$

with corresponding ordered hyperproducts to the right and to the left

$$A > B = A \times \widehat{T}^> \times B, \quad A < B = A \times \widehat{T}^< \times B, \quad (2.48a)$$

$$\widehat{I}^> > A = A > \widehat{I}^> = A, \quad \widehat{I}^< < A = A < \widehat{I}^< = A, \quad (2.48b)$$

$$\widehat{I}^> = (\widehat{I}^<)^{\dagger} = 1/\widehat{T}^>. \quad (2.48c)$$

Following the hyperlifting of the preceding methods, one reaches the following basic equations of the multi-valued hyperstructural branch of hadronic mechanics, first proposed by Santilli in monographs [13] of 1995 in the finite and infinitesimal forms

$$idA/dt = A \triangleleft H - H \triangleright A, \quad (2.49a)$$

$$A(t) = \widehat{e}^{i \times H \times t} \triangleleft A(0) \triangleright \widehat{e}^{-i \times t \times H}, \quad (2.49b)$$

which constitute the moist general possible dynamical equations known to the authors due not only to their irreversible character, but also their multivalued structure.

A rigorous formulation was then achieved in memoir [95] with the mathematician Thomas Vougiouklis. By Santilli's specific desire, the theory is now called the Santilli-Vougiouklis multi-valued hypertheory, that include as its most salient branch the multi-valued hyper-Lie theory.

2.9 Integrability Conditions for the Existence of a Lagrangian

2.9.A Integrability conditions in Newtonian mechanics (1978)

Virtually the entire scientific production of the 20th century was based on the use of Lagrangian or Hamiltonian representations of Newtonian systems, then

extended to operator formulations. Beginning with his graduate studies, Santilli set himself up to broaden these representations so as to avoid excessive abstractions and simplifications of reality, since said representations apply for point-like approximation of particles with sole action-at-a-distance interactions.

Hence, as part of his program, Santilli conducted a comprehensive study of the broadest possible systems representable via a Lagrangian or a Hamiltonian, and conducted this study via a systematic analysis of the integrability conditions for the existence of a Lagrangian or a Hamiltonian for given dynamical systems, called conditions of variational selfadjointness.

By indicating with the symbol SA (NSA) forces or equations verifying (violating) the conditions of variational selfadjointness, Santilli writes Newton's equations in a form decomposing forces into a component derivable from a potential (SA) and a second term representing all forces not derivable from a potential (NSA)

$$m \times \frac{dv}{dt} - F^{SA}(r, v) - F^{NSA}(t, r, v, \dots) = 0 \quad (2.50)$$

and writes Hamilton's equations (1.2) in the corresponding form

$$\left(\frac{dr}{dt} - \frac{\partial H(r, p)}{\partial p} \right)^{SA} = 0, \quad (2.51)$$

$$\left[\left(\frac{dp}{dt} + \frac{\partial H(r, p)}{\partial r} \right)^{SA} - F(t, r, p, \dots) \right]^{NSA} = 0. \quad (2.52)$$

As we shall see in Chapter 3, Santilli's mathematics allows the reformulation of Newton's equation into an identical selfadjoint form merely formulated on generalized spaces over generalized fields. The regaining of selfadjointness permits the recovering an action function with consequential means for a rigorous map to contact non-Hamiltonian interactions into operator forms, with endless applications.

These studies resulted in the two monographs [1, 2] indicated earlier published by Springer-Verlag, written when he was at Harvard University, with the most comprehensive references in the field up to 1982 that required Santilli one full year of search in the Cantabridgean libraries (an impeccable ethical conduct that is per se a great rarity in the contemporary widespread plagiarisms in science).

2.9.B Integrability conditions in field theory (1975)

As indicated earlier, Santilli conceived first in 1967 his Lie-admissible theory and then studied its Lie-isotopic particularization. He did the same for the conditions of variational selfadjointness. In fact, when he was at the Center for Theoretical Physics of the Massachusetts Institute of Technology in the mid

1970s, Santilli first studied the integrability conditions for the existence of a Lagrangian or a Hamiltonian for the most general possible tensorial field equations, and published their simplification for Newtonian systems reviewed above, written subsequently when he was a Harvard University.

These studies produces three memoirs [40–42] that constitute the most serious scholar works in the field and remain grossly unsurpassed to this day in their essential results and mathematical rigor.

Chapter 3

SANTILLI'S DISCOVERIES IN THEORETICAL PHYSICS

3.1 Foreword

In this chapter, we outline Santilli's most important discoveries in physics and provide copies of the original papers in free pdf downloads, when copyrighted. As it was the case for Chapter 2, we regret not to be able to outline subsequent contributions by independent researchers to avoid a prohibitive length, but they can be located in the General Bibliography on Santilli Discoveries [206].

The serious scholar is suggested not to restrict the attention solely to individual topics, but provide primary attention to the overall mathematical and physical construction with particular reference to its consistency as well as beauty.

None of the discoveries presented in this chapter has been disproved in the scientific literature to our best knowledge. Scholars are requested to inform the Foundation of the existence of papers in the refereed journal disproving any of the discoveries listed in this chapter for their outline, quotation and listing in the related section.

During the first subsections, we shall use for clarity the conventional associative multiplication AB of numbers, vector fields, operators, etc., and use the symbol $A \times B$ for the same multiplication when initiating the presentation of classical or operator generalized theories.

3.2 Ether As a Universal Substratum (1952–1955)

Santilli was fascinated by the ether (also called aether, or space) since his high school studies in the 1950 that he conducted in the city of Agnone, province of Isernia, Italy. A controversy was raging at that time on space conceived as a universal medium (or substratum) because such as conception was believed to be

in conflict with special relativity due to its foundation on the lack of existence of a privileged reference frame.

An argument used to deny the existence of space as a universal medium was the lack of “aethereal wind,” namely, the absence of any resistance by Earth during its motion in space. Another argument was the use of Einstein’s photon for the reduction of light to particles, thus eliminating the need for a medium to propagate electromagnetic waves.

In his first writings dating back to his high school years, Santilli opposed these views. To begin, he saw no conflict between the existence of a universal medium and special relativity because, assuming that an absolute reference frame can be set at rest with said universal medium, that frame cannot be identified by man precisely in view of the relativity of motion.

In 1952, when 16 years old, Santilli delivered a seminar on Albert Einstein to the teachers and students of his high school whose transcript (in Italian) has been retrieved by our Foundation from the high school documents and made available in free pdf download [26].

Next, Santilli accepted the reduction of light to photons, but only for high frequencies, such as for UV or gamma rays, and rejected the reduction to photon for electromagnetic waves at large, such as those with large wavelength (e.g., radiowaves), thus considering the notion of photon as an approximation of reality motivated by the characteristics of electromagnetic waves to cause an impulse when hitting a surface, since they carry energy. As a general position, he writes (in Italian): My voice can be heard because there is air as a medium propagating sound waves and, in the absence of air, no voice can be propagated. By the same token, my face can be seen because there is a universal medium to propagate light and, again, in the absence of a universal medium, light could not exist or propagate.

By noting that sound waves are longitudinal because the medium (air) is compressible, and by noting that electromagnetic waves are transversal, Santilli assumed that space is a universal medium with very high rigidity and, consequently, very high energy density, (otherwise light would be characterized by longitudinal or other forms of waves).

Finally, Santilli dismissed the hypothesis of the “aethereal wind” because he conceived space as the universal substratum necessary for the characterization not only of electromagnetic waves, but also of the elementary particles constituting matter, the difference being that oscillations of space propagate in the former case in the form of waves, while they are stationary in the latter case (unless moved).

In particular, Santilli assumed the electron to be a pure oscillation of space, that is, the electron is characterized by an oscillation of a point of space without any oscillating “little mass” or any other material entity, and assumed the same for all other particles constituting matter, although with a much more complex

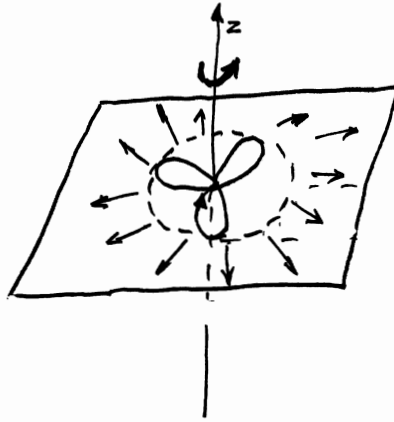

Figure 3.1. An original drawing by Santilli dating back to 1955 on his conception of the structure of the electron as a pure oscillation of a point of the ether, showing the distribution on a plane due to rotation, the longitudinal force propagated through space, thus being interpreted as the origin of the electric charge, Eq. (3.2).

oscillating structure. In this way, Santilli eliminates the “aethereal wind” by writing:

Contrary to our sensory perception, space is completely full of the universal medium, while matter is completely empty, in the sense that, following the reduction of matter to the structure of elementary particles, we have pure oscillatory energy of space without any matter component at all as perceived by us. Consequently, when we move an object, we move no material substance as perceived by us, and we merely transfer the oscillations constituting matter from one region of space to another, without any possibility for the “aethereal wind” to exist. Hence, inertia is a natural resistance by space against changes of steady propagation of the characteristic oscillations of a given body.

As we shall see, Santilli returned to his conception of space some 50 years later following his discovery of new mathematics permitting quantitative studies of the expected interconnection between space as a universal medium with high energy density and matter (achieved via the isotopies of Hilbert spaces and fields at the foundation of hadronic mechanics). In particular, his conception of space emerged rather forcefully in his studies on: the synthesis of the neutron and the expected continuous creation in our universe; alternatives to the neutrino conjecture via longitudinal impulses propagating through space; geometric propulsions with unlimited speeds without fuel tanks; and other far reaching conceptions.

Santilli’s conception of the ether. *The elements indicated above refer to studies in the 1950s. The understanding of Santilli’s conception of space requires*

the knowledge of all his studies, including experimental verifications and applications.

To begin, there is the need of a technical knowledge of Santilli's representation via hadronic mechanics of the synthesis of the neutron from a proton and an electron as occurring in Stars that requires 0.782 MeV (see Chapter 5). The only plausible origin of the missing energy is the ether because, in its absence, stars could never initiate to produce light. In fact, even a small star synthesizes at its initiation about 10^{30} neutrons per seconds, thus requiring about 10^{30} MeV that, unless supplied by the ether, would prevent any additional nuclear syntheses. This leads to the conception of the ether as a universal medium with extremely high density of positive energy, as indicated above.

But the universe is expected to be symmetric under charge conjugation. Therefore, the synthesis of the antineutron from antiprotons and antielectrons requires, this time, 0.782 MeV of negative energy (referred to a negative unit as per the isodual theory of antimatter) that, again, can solely be obtained from the ether. This leads to the additional conception that the ether is also constituted by a very large density of negative energy.

The understanding of the coexistence of the positive and negative energies in the ether requires a technical knowledge of Santilli's hypergeometries. In essence, positive and negative energies can coexist because defined in different spaces characterized by different units, the positive unit for positive energy and the negative unit for negative energy (two-valued hypergeometry). The conventional (classical) notion of vacuum originates precisely from the superposition of opposite energies defined in different spaces.

The above conception of the ether appears to be confirmed by serious studies of all existing physical knowledge from particle physics to astrophysics, such as pair creation in particle physics, neutron and antineutron stars in astrophysics, etc. The expectation is that the scholar is sufficiently serious to study Santilli's results before throwing judgments solely based on the old and surpassed knowledge of the 20th century.

Original literature. The R. M. Santilli Foundation has identified some (but not all) original writings by Santilli and we make them available here as free pdf downloads for interested scholars. We quote the first book [27] written by Santilli in 1955 (but not listed in his CV), two articles of 1955 and 1956 [28, 29] and the book [31] dated 1983. Note the title of the second article (*Elimination of the mass in atomic physics*) that anticipate the need to replace the mass with energy in Newton's and Einstein's gravitation discovered years later and outlined below.

The Foundation is interested in providing financial support to studies on the ether as a universal substratum, under the conditions that the assumed characteristics of the ether allow a quantitative representation of the transversal character

of light, as done by Santilli with his rigidity equivalence of the ether, thus excluding models of the ether as being a fluid and the like.

3.3 Origin of the Electric and Magnetic Fields (1955–1957)

As a natural continuation of the preceding conception of the ether, Santilli concentrated his attention in the structure of the electron as part of his 1957 thesis for the degree in physics at the University of Naples, Italy.

Starting from the compelling need for space to be a universal medium with high rigidity to characterize light via transversal waves propagating at very high speed, and the consequential need for the electron to be a pure oscillation of space in the sense indicated above, Santilli addressed the problem of the origin of the elementary charge and magnetic field or, equivalently, the structure of the electron.

In recollection of these studies, he states: *I believe that no study on the electron can be claimed to be of structural character unless it explains how it is possible for one electron to exercise an attractive force with a positron and a repulsive force with another electron. The conjecture I studied in the 1950s is the logical consequence that each electron (or positron) releases both attractive and repulsive forces through space, which forces are then separated by the coupling with another elementary charge.*

His main intuition is that the electron is widely represented with its well known characteristic frequency

$$\nu = \frac{\omega}{2\pi} = \frac{mc^2}{h} = 0.829 \times 10^{20} \text{ Hz.} \quad (3.1)$$

Hence, he argued that the elementary charge “e” cannot possibly be a constant as believed during the 20th century, but must also show some form of periodic time dependence. The understanding is that a collection of sufficient number of elementary charges $q = \sum_k e_k$ is indeed expected to be constant as per known experimental evidence.

The issue raised by the characteristic frequency (3.1) is the following: If space is a universal medium with high rigidity, the oscillation of one of its points will propagate an oscillating force in the medium that can be safely assumed to decay with the inverse square of the distance. However, when such a force encounters another electron (positron), it results in a repulsive (attractive) force.

The solution identified by Santilli is that the coupling of identical elementary charges activates only the repulsive part of the oscillating force, while the coupling of opposing charges activates only the attractive component of the oscillating force propagating through space.

Hence, Santilli assumed that such an oscillation transfers to space an oscillating force with the same frequency, resulting in the following structure model of

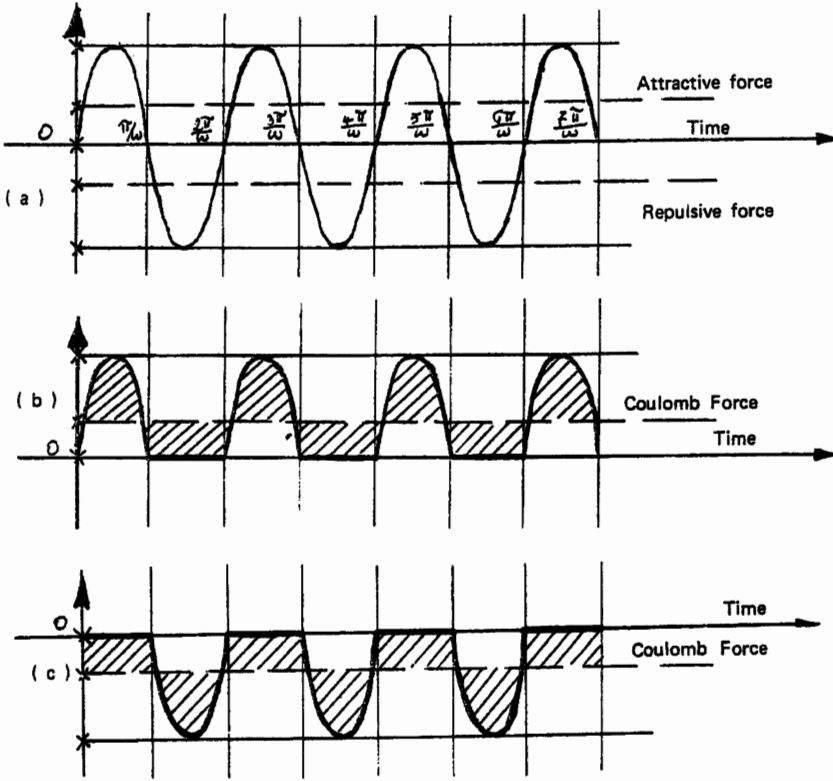

Figure 3.2. Another original drawing by Santilli dating back to 1955 on his conception of the elementary charge of the electron according to Eq. (3.2) as containing both attractive and repulsive actions (top view), which actions are separated into repulsive or attractive force when coupling elementary charges of the same or opposite sign, respectively (lower views).

the elementary electric charge

$$e = \pm(2h\nu R)^{1/2} \sin(\omega t + \alpha). \tag{3.2}$$

In this way Santilli reached in 1955 a structural generalization of the Coulomb law for two elementary charges into a time dependent, pulsating form that, for the simplest possible case of two one-dimensional oscillations along the same axis can be written

$$F = \pm \frac{e^2}{r^2} = \frac{2h\nu R}{r^2} \sin^2(\omega t + \alpha), \tag{3.3}$$

where the positive (negative) sign denotes repulsion (attraction) and R is the amplitude of the oscillation, with much more complex expressions for oscillations in two and three dimensions (see for details the literature quoted below). Needless

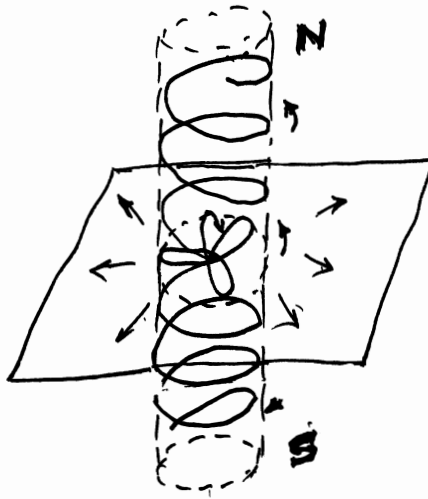

Figure 3.3. An original drawing by Santilli dating back to 1955 on his conception of the origin of the magnetic field of the electron conceived as a pure oscillation of space, showing the clear duality of the field along the rotational symmetry axis originating from deformations of space perpendicular to the characteristic structural oscillation.

to say, the actual model contains a complex phase terms in the argument of the sinus that is a function of the rotation or, equivalently, of spin $1/2$ of the electron, we cannot review here.

Santilli then concluded with the hypothesis that The repulsive force between two identical electrons is not constant, but has the shape of half a sinusoid with the characteristic frequency of the electron. It should be indicated again that the above hypothesis solely applies for two electrons because, when considering a large number of electrons, the above periodicity is evidently averaged out, resulting into a constant force.

The conception of the electron as a pure oscillation of space is far from being trivial and should be taken seriously by researchers in the field, if nothing else, because alternative hypotheses appears to lack plausibility. In fact, the addition of rotation to the pure oscillation of space creates a rosetta-type planar distribution with an $SO(2)$ symmetry that (unlike the $SO(3)$ case) admits angular momentum $1/2$ as the lowest non-null state, thus allowing a structure model of the electron spin.

Additionally, an oscillation of a point of a rigid medium propagates two different impulses in the medium, the radial one identified with the origin of the electric charge, and the transversal one that propagates in the two directions opposite to the oscillation thus having all prerequisites for their interpretation as the origin of the elementary magnetic dipole moment, as illustrated in the figure.

Half a century has passed since these pioneering studies and, in view of the obscurantism created by Einsteinian theories, studies on space as a universal substratum have been vastly ignored by the so-called “mainstream” of physics research, with the consequential dismissal of studies on the origin of the electromagnetic field in favor of its description.

Yet, Santilli must be credited to have voiced a restoration of serious scientific democracy with the addressing of truly fundamental physical issues irrespective of their political implications, a pattern that has been at the basis of Santilli’s entire life.

Our Foundation has retrieved Santilli’s thesis (in Italian) at the University of Naples on the structure of the electron and the origin of its electromagnetic field, and makes it available in free pdf download [30].

Subsequently, Santilli was engaged in otehr research and returned to study the above ideas in early 1080s, nd released two short papers for publication in the Hadronic Journal [46] and in Nuovo Cimento Letters [55] merely to have a (generally ignored) record of his studies.

The connection between Santilli’s structure model of the electron and string theories (appeared some half a century later) should be noted. Unfortunately, the latter have been patterned along the requirements of representing extended particles while verifying special relativity, a notorious impossibility since the latter solely admit point-particles as indicated earlier.

In Santilli’s views, string theories essentially constitute an edifice built without foundation due to the lack of general identification of the truly fundamental notion, the entity that vibrates thus permitting the existence of the strings. This identification is generally omitted because the universal substratum would be perceived as violating special relativity due to its notorious lack of an absolute reference frame. Additionally, string theories in their current formulation verify the Theorems of Catastrophic Mathematical and Physical Inconsistencies of Noncanonical and Nonunitary Theories reviewed in Section 3.9. Due to these unsettled basic issues, string theories will be ignored hereon. Yet, it is clear that Santilli’s structure model of the electron can indeed provide plausible foundations to string theories, and their reconstruction based on a universal substratum and related advances is here recommended.

3.4 Origin of the Gravitational Field (1974)

Following the above pioneering studies on the structure of space and the origin of the electromagnetic field, it was natural for Santilli to study the origin of the gravitational field. This study was conducted in the 1970s when he was at the Center for Theoretical Physics of the Massachusetts Institute of technology.

Santilli initiated the study with the origin of the exterior gravitational field for the most elementary particle, the electron, whose mass is well known to be

entirely of electromagnetic origin. Hence, he reached the conclusion that the gravitational field of an electron is entirely of electromagnetic origin, and wrote the gravitational field equations on a Riemannian space in the form

$$R_{\mu\nu} + g_{\mu\nu}R = kT_{\mu\nu}, \quad (3.4)$$

where T is the energy-momentum tensor of the electromagnetic field of the electron and k is a constant. It should be stressed that, in Eqs. (3.4), $T_{\mu\nu}$ is a source tensor of first order in magnitude that, as such, cannot be ignored in first approximation as usual in the field.

The above case is well known but ignored in the sense that, when passing to neutral matter, it is customary to assume that mass is the origin of the gravitational field. Therefore, Santilli studied the exterior gravitational field of the π^0 particle as a bound state of one charged constituent called "parton" and its antiparticle (assumed to have the same elementary structure of the electron). The constituents were assumed to be in very high rotation at 1 fm mutual distance with tangential speeds close to that of light. By using the most advanced relativistic calculations, Santilli discovered that the mass of the π^0 is also of entire electromagnetic origin. Therefore, for the gravitational field of the π^0 Santilli wrote the field equation in the form (3.4), namely, with a first order source tensor in the r.h.s.

He then passed to the study of ordinary massive bodies and reached the conclusion that the exterior gravitational field in vacuum of an ordinary massive body is entirely generated by the sum of the electromagnetic fields of all elementary constituents of the body considered, with field equations of type (3.4) having a source tensor in the r.h.s. of first order in magnitude, irrespective of whether the body considered is neutral or charged and with or without a magnetic field. In this case, Santilli characterized the source tensor T as the sum of a very large number of individual contributions and provided methods for its average.

He then passed to the problem of the origin of the interior gravitational field by recalling that, from a structural viewpoint, the main difference between the exterior and the interior problem is the additional presence in the interior case of short range, weak and strong interactions. Hence, for the interior gravitational problem of the π^0 particle, he wrote the field equations in the form

$$R_{\mu\nu} + g_{\mu\nu}R = kT_{\mu\nu} + wW_{\mu\nu}, \quad (3.5)$$

where $W_{\mu\nu}$ is the energy-momentum tensor due to weak and strong interactions in the interior of the π^0 and w is another constant.

Santilli also noted that: the tensor $T_{\mu\nu}$ is traceless, while the tensor $W_{\mu\nu}$ is not; the source tensor of the interior problem has a bigger numerical value of that for the exterior problem; and, consequently, he concluded that the inertial mass is bigger than the gravitational one, the former (latter) being characterized by the interior (exterior) problems.

Santilli then compared the above results (reached via first principles of quantum electrodynamics) with Einstein's conception of the exterior gravitational problem that, as well known, is based on its entire reduction to curvature without any source for neutral bodies, and celebrated field equations

$$R_{\mu\nu} + g_{\mu\nu}R = 0. \quad (3.6)$$

From the evident differences between Eqs. (3.4) or (3.5) and (3.6), Santilli concluded that: Einstein conception of gravitation as pure curvature is irreconcilably incompatible with quantum electrodynamics because, either

A) One assumes Einstein gravitation as being correct, in which case classical and quantum electrodynamics must be profoundly reformulated in such a way to avoid a first order electromagnetic contribution to masses; or

B) One assumes quantum electrodynamics as being valid, in which case Einstein's reduction of gravity to pure curvature without source (for the case of neutral bodies) must be abandoned.

Santilli then concluded the study of 1974 with its evident consequence: The electromagnetic origin of the gravitational fields implies their "identification," thus eliminating the need for their "unification", with the understanding that the former (latter) field is described by second-order (first-order) equations.

In the late 1990s, Santilli added the proof that Einstein's field equations for a neutral body are additionally incompatible with the Feud identity of the Riemannian geometry, since the latter requires two source tensors in the r.h.s of the field equations, one traceless and the other with trace, exactly as predicted by the origin of the interior gravitational field, Eqs. (3.5). Santilli also identified numerous additional inconsistencies of Einstein's gravitation reviewed later on in this chapter.

The implications of the above studies are far reaching, even though vastly ignored for evident political reasons of not being aligned with Einsteinian doctrines. In fact, Santilli's identification of the gravitational and electromagnetic fields implies:

A) The evident equivalence of phenomenologies, that is, gravity must admit attraction and repulsion since that is the case for the electromagnetic field. This problem was resolved by Santilli via the construction of the isodual theory of antimatter (see later on Section 3.19);

B) The possibility of resolving the century old unresolved problem of a consistent operator form of gravity, that was subsequently achieved by Santilli via his isogravity (see Section 3.11);

C) The need to formulate the scattering theory in such a way to incorporate, apparently for the first time, gravitational contributions, due to the possible creation of, Mini Black Holes since the latter depend on sufficient energy density, and not necessarily occur solely for large masses (see Chapter 5).

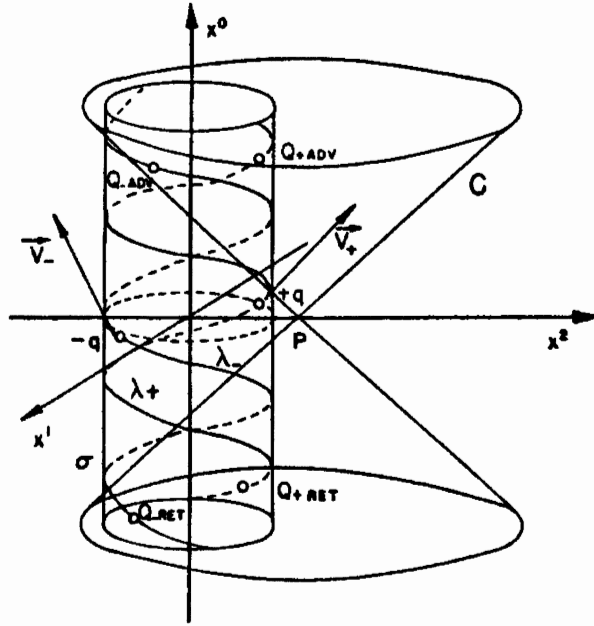

Figure 3.4. A schematic view of the calculations via advanced and retarded field theoretical methods, used by Santilli in 1974 to establish the incompatibility of Einstein's gravitation with quantum electrodynamics, in this case showing the entire electromagnetic origin of the exterior gravitational mass of the π^0 particle, in irreconcilable disagreement with the null source of Einstein's field equations for the case considered.

The origin of the gravitational field and its identification with the electromagnetic field were published by Santilli in paper [39]. The violation by Einstein's gravitation of the Freud identity of the Riemannian geometry for neutral bodies and nine inconsistency theorems were presented in paper [119] with a general review in volume [20].

3.5 Symmetry of the Ether (1970)

As indicated earlier, Santilli considers the ether (or space) to be a universal substratum permitting the existence of all visible universe, thus being the most fundamental and final frontier of scientific knowledge. The physics community of the 20th century did not accept this notion because it implies an absolute reference frame that is perceived as being prohibited by special relativity, thus adapting nature to a preferred theory.

Being a physicist interested in quantitative studies, it was natural for Santilli to search for the symmetry of the ether, that is, the spacetime symmetry admitting indeed a universal substratum for all visible events, while, of course, being

compatible with available experimental evidence. The absence of such a symmetry originates from the fact that there is no possibility to characterize said notion of the ether via the spacetime symmetry of the 20th century, the 10-dimensional Poincaré symmetry, here indicated in its simpler connected form

$$P(3.1) = SO_6(3.1) \otimes T_4(3.1), \quad (3.7)$$

where $SO_6(3.1)$ represents the connected 6-dimensional Lorentz symmetry; $T_4(3.1)$ is the group of translations in Minkowski spacetime; and \otimes is the semidirect product.

Hence, Santilli searched for a broadening of the Poincaré symmetry in such a way to admit special relativity as a particular case, while allowing means for the characterization of the ether via a primitive, spacetime symmetry.

The solution was presented in a series of papers written from 1970 on by Santilli in collaboration with P. Roman and J.J. Aghassi at the Department of Physics of Boston University. The proposal consisted in the 15-dimensional ether symmetry as called privately by Santilli and officially called in publications the relativistic Galilei group $G_5(3+2)$ where 5 denotes the extension of the 4-dimensional Minkowski spacetime with coordinates x^μ , $\mu = 1, 2, 3, 4$, plus an additional scalar u characterizing the ether as a universal medium, e.g., u representing the ether proper time. The new symmetry is characterized by the transformations

$$\text{Lorentz transformations } x^\mu \rightarrow \Lambda^\mu_\nu x^\nu, \quad (3.8)$$

$$\text{Spacetime translations } x^\mu \rightarrow x^\mu + a^\mu, \quad (3.9)$$

$$\text{Spacetime boosts } x^\mu \rightarrow x^\mu + b^\mu u, \quad (3.10)$$

$$\text{Proper time translation } u \rightarrow u + \sigma, \quad (3.11)$$

with group structure

$$G_5(3,2) = SO_6(3.1) \otimes T_4(3,1) \otimes T_4(b) \times T_1(\sigma) \quad (3.12)$$

and generators of the Lie algebra

$$g_5 = J_{\mu\nu}, P_\mu, X_\mu, E, \quad (3.13)$$

where $J_{\mu\nu}$ and P_μ are the conventional generators of the Poincaré algebra; X_μ is a position operator, and E is the energy operator, the latter operators being a novelty of the new symmetry since they are impossible for the Poincaré symmetry. For additional technical data, interested readers are suggested to consult the literature below.

In summary, the Poincaré symmetry can be extended into the ether symmetry (or the relativistic Galilei symmetry) $G_5(3,2)$ that admits as a subgroup both the Poincaré symmetry and the conventional (nonrelativistic) Galilei symmetry, as

well as fundamental new features that are impossible in the Poincaré symmetry, such as the position and energy operators, a universal constant (originating from the scalar extension) and other intriguing features.

A possible use of the ether symmetry is the following. The Poincaré component is used for the representation of all data connected to special relativity with no change, including the adoption of all its experimental verifications. The remaining components mainly represent the interplay between cosmological aspects, the universal medium, and the event considered. The latter cause the emergence of position and energy operators that are an evident consequence of the introduction of the proper time of the ether.

Needless to say, it would be presumptuous to claim that the ether symmetry is the correct spacetime symmetry for relativistic dynamics, and the same holds for the believe of the Poincaré symmetry as the final spacetime symmetry to the end of time. Yet, it is the Foundation's opinion that, until experimental evidence disproving the new symmetry is identified, the ether symmetry is superior to the Poincaré symmetry, if nothing else, because of the much broader conception and representational capability.

The historical papers presenting the new spacetime symmetry are [35, 36]. For numerous additional papers, particularly those on the representation theory and applications, interested scholars are suggested to consult Santilli curriculum. An important study of the nonrelativistic case has been done by H. E. Wilhelm in paper [195]. An important independent study has been made by J. R. Fanchi in recent memoir [196].

The reader should be aware that the American Physical Society prohibited any mention of the use intended by Santilli of the relativistic Galilei symmetry for the characterization of a universal substratum, for the evident political reason to avoid the perception of the paper being incompatible with Einsteinian doctrines. The presentation of the new symmetry adopted above has been derived by the Foundation from Santilli's unpublished manuscripts of the time, and coincides with the above quoted *Phys. Rev. paper* only in the formulae.

3.6 QFT (And QCD) Violations from Discrete Symmetry Violations (1974)

The rigorous implementation of Lie's theory demands that the fundamental symmetry of special relativity, the Poincaré symmetry, is given by a continuous component characterized by the (connected) Lorentz symmetry, and discrete components characterized by space and time inversions.

In the early part of the 20th century, the entire Poincaré symmetry was assumed to be exactly valid throughout the universe. The discovery of parity violation by weak interactions, rather than causing scientific joy, caused panic among the Einsteinian followers because of fear that the entire edifice may collapse. Organized

interests on a world wide basis were then activated in the physics community to reach a vast consensus, intentionally without any technical inspection, that “the violation of discrete symmetries does not cause the violation of the continuous component of the Poincaré symmetry or of special relativity,” a popular political belief without scientific process that is still widespread at this writing (mid 2008).

Thanks to his notorious independence of thought from popular, academic beliefs, Santilli conducted in the 1970s quantitative technical studies as to whether the violation of discrete symmetries implies that of the connected Lorentz symmetry and, consequently, of special relativity. The analysis was conducted with the most advanced and rigorous technical knowledge in quantum field theory of the time, that via Wightman’s axioms.

Being an applied mathematician, Santilli was fascinated by the beauty of quantum field theory (QFT) characterized by Wightman axioms. However, being a physicist, he also knew that such a theory had to admit limits of exact applicability because physics will never admit final theories to the end of time. Thus, he initiated comprehensive studies for the identification of such limits of applicability as a necessary foundation for suitable covering theories. The reader should be aware that these studies are of extreme complexity and, therefore, can be only reviewed here in their main conceptual lines.

The discrete symmetries of quantum field theories are given by the following operations and their combinations:

$$\begin{aligned} &P \text{ (space inversion), } C \text{ (charge conjugation), } T \text{ (time inversion),} \\ &PC, CT, PT, PCT. \end{aligned} \tag{3.14}$$

The PCT theorem within the context of vacuum expectation values (VEV) verifying Wightman’s axioms essentially related the PCT conditions to the weak local commutativity conditions (WLC) under the assumption of Lorentz invariance for the vacuum expectation values plus, boundedness of the energy from below and other conditions permitting smooth analytic continuations.

While supervising a Ph. D. thesis of one of his students at the Department of Physics of Boston University (the Greek physicist C.N. Ktorides), Santilli achieved the extension of the PCT theorem to all discrete spacetime symmetries, a possibility simply unknown at that time. To achieve this goal, he derived the following dual discrete symmetries:

$$\begin{aligned} P^\# &= (PC)(WLC), C^\# = WLC, T^\# = (TC)(WLC), PC^\# = P(WLC), \\ CT^\# &= T(WLC), PT^\# = (PCT)(WLC), PCT^\# = PT(WLC), \end{aligned} \tag{3.15}$$

and proved the following:

THEOREM 3.6A: Under Lorentz invariance, analyticity and energy boundedness from below, the validity (at a Jost point) of any discrete symmetry in a

quantum field theory satisfying the Whitman axioms implies that of its dual and vice versa:

$$\begin{aligned} P \leftrightarrow T^\#, C \leftrightarrow PCT^\#, T \leftrightarrow P^\#, PC \leftrightarrow CT^\#, \\ CT \leftrightarrow PC^\#, PT \leftrightarrow C(WLC), PCT \leftrightarrow C^\#. \end{aligned} \quad (3.16)$$

The implications of the above discovery presented in the papers quoted below are the following: For quantum field theories admitting discrete symmetries, Santilli's Theorem 3.6A implies the validity of basically new discrete symmetry that can be experimentally verified. For theories violating any discrete symmetry, Theorem 3.6A implies that, whenever a discrete symmetry is violated, the corresponding dual symmetry has to be violated too, and vice versa. The original 1974 paper can be downloaded from link [37]. The reading of the preceding paper [38], also at the *Phys. Rev.*, is instructive.

It should be noted that the results reported above solely present the version published by *Phys. Rev.* and not the complete research conducted by Santilli. In essence, the editors of *Phys. Rev.* kept the paper for years without accepting it and without rejecting it, evidently due to the absence of a credible technical counter-arguments (in the 1970s, technical arguments were required for a rejection, something abandoned these days at the American and other Physical Societies).

Santilli finally understood the reason for the delay, changed the final parts, and the paper was accepted and published immediately thereafter. The political problems were multifold. The first problem was caused by the conclusion stating that, in the event a given discrete symmetry and its dual are violated, the Wightman axioms are violated too. This evident conclusion had to be removed from the paper for its publication, as confirmed by Santilli recollections, because Wightman was in control of quantum field theory of the time.

The biggest political problem, was, however, caused by Santilli's analytic continuation of a discrete symmetry to its connected component as expected from Lie's theory, namely, the achievement of the original goal of deriving the lack of exact character of the (continuous) Lorentz transformations from the violation of a discrete symmetry. Unfortunately, the Foundation could not identify any of Santilli's original manuscripts in the field. Following consultation, Santilli released the following statement: A direct test of the applicability or inapplicability of special relativity under conditions violating discrete symmetries was inconceivable in the 1970s as it is inconceivable today due to organized opposing interests controlling major particle laboratories around the world.

This scientific obscurantism is implemented despite the evidence that a theory, such as special relativity, that is strictly invariant under time reversal, cannot possibly be exact for a strictly irreversible process, such as a weak interaction decay, since the scattering amplitude is invariant under time reversal, thus pre-

dicting the spontaneous recombination of the debris of the decay into the original particle.

Due to this unfortunate political control of basic physical knowledge, in the 1970s I asked myself whether there was any way of establishing the lack of exact character of the connected component of the Lorentz symmetry from the violation of its discrete component. To my best recollection, I did find an analytic continuation connecting said components in such a way that the violation of one would imply that of the other.

However, for scientific honesty, I have to stress that I am not sure whether the derivation was correct due to lack of its technical review by the American Physical Society. Also, in view of the extreme complexity of the field in which I have not conducted research for some thirty years, I do not have the time to reconsider it now.

I am proud for my reputation of never accepting abuses without due response. In this particular case, the defense of the Ph. D. thesis of my student Ktorides was at stake because crucially dependent on the publication of the paper by *Phys. Rev.* Hence, I had to accept the political manipulation of the conclusions by the editors of *Phys. Rev.* and their referees to allow Ktorides graduation.

Following the appearance of the 1974 paper, I destroyed the entire file out of sheer rage that, in a seemingly democratic country, the American Physical Society was allowed such a totalitarian control of fundamental human knowledge in complete impunity and without any control by the country.

The Foundation is interested in supporting research on "Santilli problem in quantum field theory," namely, whether there is an analytic continuation or other mechanism under which the violation of a discrete symmetry causes the inapplicability of the Lorentz symmetry and special relativity.

3.7 Resolution of the Historical Imbalance on Antimatter (1994)

3.7.A Apparent lack of visibility of antimatter asteroids with Sun light

Santilli has achieved, for the first time to our knowledge, a representation of antimatter at all possible levels, from Newtonian mechanics to second quantization and for conditions of increasing complexity, from fully conservative conditions to the most general possible irreversible non-Hamiltonian conditions, as well as hyperstructural conditions expected in possible antimatter living structures.

These studies are far from trivial and have direct implications for the very safety of our planet, since they predict that antimatter asteroids are not visible with the light of our matter Sun. In fact, the studies predict that light emitted by a matter star annihilates when hitting an antimatter body without any refraction. Alternatively, the studies predict that light emitted by an antimatter star, called

by Santilli isodual light, annihilates when hitting matter, thus not reaching us on Earth due to annihilation in the upper atmosphere, as it is the case for antimatter cosmic rays.

In short, Santilli has initiated an entire new field called antimatter astrophysics whose primary aim is the identification of methods for the detection of antimatter stars, by nothing that their isodual light is expected to annihilate even in lenses of telescopes orbiting in space, thus requiring a basically new conception of antimatter telescopes.

it should be noted that, as recalled in Chapter 1, Einstein special and general relativity have no means for differentiating between neutral matter and antimatter as expected for asteroids and stars. As a consequence, antimatter has been assumed as being nonexistent in the universe in any appreciable amount. Santilli's discoveries indicates that antimatter has not been detected because of the above indicated occurrences, namely, the annihilation of our Sun light in an antimatter asteroid, or the annihilation of light from an antimatter star in our atmosphere or in orbiting telescopes.

It is evident that the very safety of our planet is at stake on the above issues due to the evidence reviewed in Chapter 1 and below that Earth has indeed been hit in the past by antimatter asteroids, as it is the case for the celebrated Tunguska explosion in Siberia with the power of 1,000 atomic bombs, yet without any debris whatsoever in the ground. If such a catastrophe did occur in the past, it may occur again. Therefore, the sole scientific approach is that of considering all possible alternatives and resolving them via measurements, rather than via personal beliefs one way or another.

In this section we outline the most elementary level of study, that for point-like abstractions of antiparticles under sole potential interactions. The subsequent levels of study are given by the broader isodual isotopic, genotopic and hyperstructural theories that cannot possibly be reviewed in this presentation, but can be constructed via an isodual map of matter theories.

3.7.B Newton-Santilli isodual equation for antimatter

As recalled in Section 1.4, no consistent classical theory of antimatter existed prior to Santilli's research, to our best knowledge. For instance, by resuming the use of the conventional associative multiplication $a \times b = ab$, the celebrated Newton's equation

$$m \times \frac{dv}{dt} = F(t, r, v, \dots) \quad (3.17)$$

or the celebrated Newton's gravitation

$$F = g \times m_1 \times m_2 / r^2 \quad (3.18)$$

solely apply for matter, and have no means whatsoever to distinguish between matter and antimatter for the very simple reason that antimatter was inconceivable at Newton's times.

Thanks to the prior discovery of his isodual mathematics outlined in Chapter 2, Santilli developed the isodual theory of antimatter that holds at all levels of study, thus restoring full democracy between matter and antimatter.

In essence, in the 20th century antimatter was empirically treated by merely changing the sign of the charge, under the tacit assumption that antimatter exists in the same space as that for matter. Thus, both matter and antimatter were studied with respect to the same numbers, fields, spaces, etc. However, a correct classical representation of antimatter required a mathematics that is anti-isomorphic to that used for matter as a necessary condition to admit a charge conjugated operator image.

Santilli represents antimatter via his anti-Hermitean isodual map (2.9) that must be applied to the totality of quantities used for matter and all their operations. Hence, under isoduality, we have not only the change of the sign of the charge, but also the isodual conjugation of all remaining physical quantities (such as coordinates, momenta, energy, spin, etc.) and all their operations. This is the crucial feature that allows Santilli to achieve a consistent representation of antimatter also for neutral bodies.

We have in this way the Newton-Santilli isodual equation for antiparticles that we write in the simplified form

$$m^d \times^d d^d v^d / d^d t^d = F^d(t^d, r^d, v^d, \dots), \quad (3.19)$$

where "d" denotes isodual map (2.9), and the same conjugation holds for gravitation (see below).

Note that, after working out all isodual maps, antiparticle equation (3.19) merely yields minus the value of the conventional equation for particles in both the l.h.s. and the r.h.s, thus appearing to be trivial. However, a most important feature of the above equation is that it defines antiparticles in a new space, the Euclid-Santilli isodual space, that is coexistent but different than our own space. The Euclidean space and its isodual then form a two-valued hyperspace.

In this section we shall show that, starting from the fundamental equation (3.19), the isodual theory of antimatter is consistent at all subsequent levels, including quantization, at which level it is equivalent to charge conjugation.

Note that isodual antiparticles have a negative energy. This feature is dismissed by superficial inspections as being nonphysical, thus venturing judgments prior to the acquisition of technical knowledge. In fact, negative energies are indeed nonphysical, but when referred to our spacetime, that is, with respect to positive units of time. By contrast, when referred to negative units, all known objections on negative energies become inapplicable, let alone resolved.

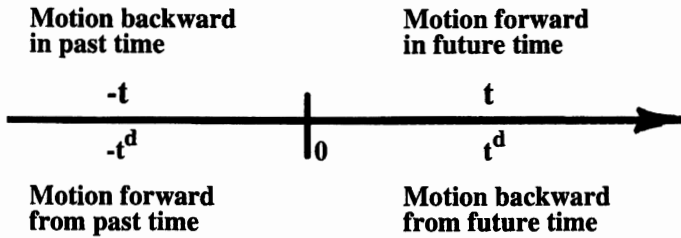

Figure 3.5. Contrary to popular beliefs, time has *four* directions as depicted by Santilli in this figure to illustrate the need for isoduality. In fact, time reversal can only allow the representation of two time directions. The remaining two time directions can solely be represented via the isodual map.

Note also that isodual antiparticles move backward in time. This view was originally suggested by Stueckelberger in the early 1900s, and then adopted by various physicists, such as Feynman, but dismissed because of causality problems when treated with our own positive unit of time. Santilli has shown that motion backward in time referred to a negative unit of time $t^d = -t$ is as causal as motion forward in time referred to a positive unit of time t , and this illustrates the nontriviality of the isodual map.

Moreover, the assumption that particles and antiparticles have opposing directions of time is the only one known giving hopes for the understanding of the process of annihilation of particles and their antiparticles, a mechanisms utterly incomprehensible for the 20th century physics.

3.7.C Isodual Representation of the Coulomb Force

The isodual theory of antimatter verifies all classical experimental evidence on antimatter because it recovers the Coulomb law in a quite elementary way. Consider the case of two particles with the same negative charge and Coulomb law

$$F = (-q_1) \times (-q_2)/(r \times r), \tag{3.20}$$

where the positive value of the r.h.s is assumed as representing repulsion, and the constant is assumed to have the value 1 for simplicity.

Under isoduality, the above expression becomes

$$F^d = (-q_1)^d \times^d (-q_2)^d /^d (r^d \times^d r^d), \tag{3.21}$$

thus reversing the sign of the equation for matter, $F^d = -F$. However, antimatter is referred to a negative unit of the force, charge, coordinates, etc. (Chapter 2). Hence, a positive value of the Coulomb force referred to a positive unit represent-

ing repulsion is equivalent to a negative value of the Coulomb force referred to a negative unit, and the latter also represents repulsion.

For the case of the electrostatic force between one particle and an antiparticle, the Coulomb law must be projected either in the space of matter

$$F = (-q_1) \times (-q_2)^d / (r \times r) \quad (3.22)$$

representing attraction, or in that of antimatter

$$F = (-q_1)^d \times^d (-q_2)^d / (r^d \times^d r^d), \quad (3.23)$$

in which case, again, we have attraction, thus representing classical experimental data on antimatter.

3.7.D Hamilton-Santilli isodual mechanics

To proceed in his reconstruction of full democracy in the treatment of matter and antimatter, Santilli had to construct the isodual image of Hamiltonian mechanics because essential for all subsequent steps. In this way he reached what is today called the Hamilton-Santilli isodual mechanics based on the isodual equations

$$d^d r^d / d^d t^d = \partial^d H^d(r^d, p^d) / \partial^d p^d, \quad d^d p^d / d^d t^d = -\partial^d H^d(r^d, p^d) / \partial^d r \quad (3.24)$$

and their derivation from the isodual action A^d (a feature crucial for quantization), from which the rest of the Hamilton-Santilli isodual mechanics follows.

3.7.E Isodual special and general relativities

As indicated in Section 1.4, special and general relativities are basically unable to provide a consistent classical treatment of antimatter. Santilli has resolved this insufficiency by providing a detailed, step by step isodual lifting of both relativities with a mathematically consistent representation of antimatter in agreement with classical experimental data (see below for the quantum counterpart).

The reader should be aware that the above liftings required the prior isodual images of the Minkowskian geometry, the Poincaré symmetry and the Riemannian geometry, as well as the confirmation of the results with experimental evidence.

3.7.F Prediction of antigravity

Studies on antigravity were dismissed and disqualified in the 20-th century on grounds that “antigravity is not admitted by Einstein’s general relativity.” This posture resulted in a serious obscurantism because general relativity cannot represent antimatter, thus being disqualified for any serious statement pertaining to the gravity between matter and antimatter.

Thanks to his isodual images of special and general relativity, Santilli has restored a serious scientific process in the field, by admitting quantitative studies for all possibilities, and has shown that once antimatter is properly represented, matter and antimatter must experience antigravity (defined as gravitational repulsion) because of supporting compatible arguments at all levels of study, with no known exclusion. In fact, all known "objections" against gravitational repulsion between matter and antimatter become inapplicable under Santilli isoduality, let alone meaningless.

The arguments in favor of the above conclusion are truly forceful because differentiated and mutually compatible. As a trivial illustration, we have the repulsive Newton-Santilli force between a particle and an isodual particle (antiparticle) both treated in our space

$$F = g \times m_1 \times m_2^d/r^2 = -g \times m_1 \times m_2/r^2, \quad (3.25)$$

which is indeed repulsive. The same conclusion is reached at all levels of study.

It should be indicated that a very compelling aspect supporting antigravity between matter and antimatter is Santilli's identification of gravity and electromagnetism indicated in Section 3.4. In fact, the electromagnetic origin of exterior gravitation mandates that gravity and electromagnetism must have similar phenomenologies, thus including both attraction and repulsion.

3.7.G Test of antigravity

Santilli has proposed an experiment for the final resolution as to whether antiparticles in the gravitational field of Earth experience attraction or repulsion. The experiment consists in the measure of the gravitational force of a beam of positrons in flight on a horizontal vacuum tube 10 m long at the end of which there is a scintillator. Then, the displacement due to gravity is visible to the naked eye under a sufficiently low energy (in the range of the 10^{-3} eV). The experiment was studied by the experimentalist Mills and shown to be feasible with current technologies and resolutory.

3.7.H Isodual quantum mechanics

Next, Santilli constructed a step-by-step image of quantum mechanics under his isodual map based on the Heisenberg-Santilli isodual time evolution for an observable Q

$$i^d \times^d d^d Q^d / d^d t^d = [Q, H]^d = H^d \times^d Q^d - Q^d \times^d H^d, \quad (3.26)$$

and related isodual canonical commutation rules, Schrödinger-Santilli isodual equations, etc.

He then proved that, at the operator level, isoduality is equivalent to charge conjugation. Consequently, the isodual theory of antimatter verifies all experimental

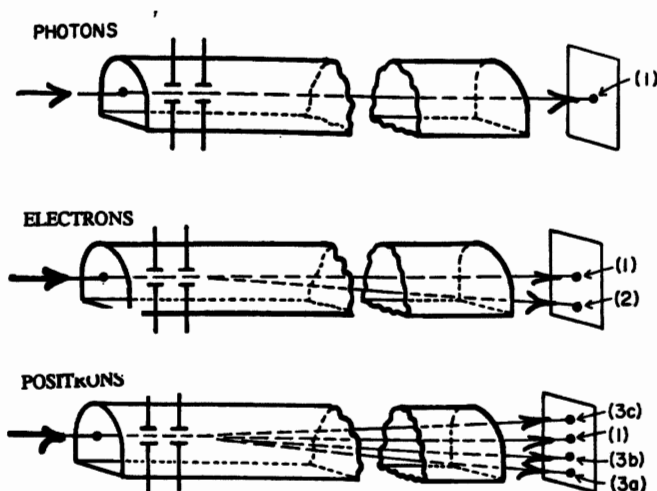

Figure 3.6. The original illustration used by Santilli for the 1994 proposal to test the gravity of positrons in horizontal flight in a vacuum tube. The proposal has been qualified by experimentalists as being technically feasible nowadays and resolutive because the displacement due to gravity on a scintillator at the end of a 10 m flight for positrons with milli-eV energy is visible to the naked eye. The usual criticisms based on disturbances caused by stray fields have been disqualified as political for a tube with at least 50 cm diameter. Virtually all major physics laboratories around the world have rejected even the consideration of the test, despite its dramatically lower cost and superior scientific relevance compared to preferred tests, on grounds that “Einstein theories do not admit antigravity,” although with documented knowledge that said theories cannot consistently represent antimatter as reviewed in the test.

data at the operator level too. Nevertheless, there are substantial differences in treatment, such as:

1) Quantum mechanics represents antiparticles in the same space of particles, while under isoduality particles and antiparticles exist in different yet coexisting spaces;

2) Quantum mechanics represents antiparticles with positive energy referred to a positive unit, while isodual antiparticles have negative energies referred to a negative unit;

3) Quantum mechanics represents antiparticles as moving forward in time with respect to our positive time unit, while isodual antiparticles move backward in time referred to a negative unit of time.

3.7.I Experimental detection of antimatter galaxies

Recall from Chapter 2 that the isodual theory of antimatter was born out of Santilli's frustration as a physicist for not being able to ascertain whether a far away star, galaxy or quasar is made up of matter or of antimatter. Santilli has resolved this uneasiness via his isodual photon γ^d namely, photons emitted by antimatter that have a number of distinct, experimentally verifiable differences with respect to photons γ emitted by matter,

$$\gamma^d \neq \gamma, \quad (3.27)$$

thus allowing, in due time, experimental studies on the nature of far away astrophysical objects.

A most important difference between photons and their isoduals is that the latter have negative energy, as a result of which, isodual photons emitted by antimatter are predicted to be repelled in the gravitational field of matter. A possibility for the future ascertaining of the character of a far away star or quasar is, therefore, the test via neutron interferometry or other sensitive equipment, whether light from a far away galaxy is attracted or repelled by the gravitational field of Earth (for other possibilities see the literature quoted below).

3.7.J The new isoselfdual invariance of Dirac's equation

Santilli has released the following statement on the Dirac equation: I never accepted the interpretation of the celebrated Dirac equation as presented in the 20-th century literature, namely, as representing an electron, because the (four-dimensional) Dirac's gamma matrices are generally believed to characterize the spin 1/2 of the electron. But Lie's theory does not allow the SU(2)-spin symmetry to admit an irreducible 4-dimensional representation for spin 1/2, and equally prohibits a reducible representation close to the Dirac's gamma matrices.

Consequently, Dirac equation cannot represent an electron intended as an elementary particle since elementarily requires the irreducible character of the representation. In the event Dirac's gamma matrices characterize a reducible representation of the SU(2)-spin, Dirac's equation must represent a composite system.

I discovered the isodual theory of antimatter by examining with care Dirac's equation. In this way, I noted that its gamma matrices contain a conventional two-dimensional unit $I_{2 \times 2} = \text{Diag.}(1, 1)$, as well as a conjugate negative-definite unit $-I_{2 \times 2}$. That suggested me to construct a mathematics based on a negative definite unit. The isodual map come from the connection between the conventional Pauli matrices σ_k , $k = 1, 2, 3$, referred to $I_{2 \times 2}$ and those referred to $-I_{2 \times 2}$. In this way I reached the following interpretation of Dirac's gamma matrices as being the tensorial product of $I_{2 \times 2}$, σ_k times their isoduals,

$$\{I_{2 \times 2}, \sigma_k, k = 1, 2, 3\} \times \{I_{2 \times 2}^d, \sigma_k^d, k = 1, 2, 3\}. \quad (3.28)$$



Figure 3.7. An illustration of the serious implications of Santilli's isodual theory of antimatter: the need for a revision of the scattering theory of the 20th century due to its violation of the isoselfdual symmetry of Dirac's equation. The diagram in the left illustrates the isoselfduality of the initial particles (an electron and a positron) but its violation in the final particles (two identical photons). The diagram in the right illustrates one of the several needed revisions, the use for final particles of a photon and its isodual as a necessary condition to verify the new isoselfdual symmetry. Additional dramatic revisions are due to the purely action-at-a-distance, potential interactions of the conventional scattering theory (represented with a waving central line in the left diagram), compared to the non-Hamiltonian character of the scattering region caused by deep penetrations of the wavepackets of particles (represented with a circle in the right diagram). A review of the novel hadronic scattering theory is presented in Chapter 5.

Therefore, I reached the conclusion that the conventional Dirac equation represents the tensorial product of an electron and its isodual, the positron. In particular, there was no need to use the "hole theory" or second quantization to represent antiparticles since the above re-interpretation allows full democracy between particles and antiparticles, thus including the treatment of antiparticles at the classical level, let alone in first quantization.

By continuing to study Dirac's equation without any preconceived notion learned from books, I discovered yet another symmetry I called **isoselfduality**, occurring when a quantity coincides with its isodual, as it is the case for the imaginary unit $i^d = i$. In fact, Dirac's gamma matrices are isoselfdual,

$$\gamma_\mu^d = \gamma_\mu, \quad \mu = 0, 1, 2, 3. \quad (3.29)$$

This new invariance can have vast implications, all the way to cosmology, because the universe itself could be isoselfdual as Dirac's equation, in the event composed of an equal amount of matter and antimatter. In conclusion, Dirac's equation is indeed one of the most important discoveries of the 20-th century with such a depth that it could eventually represent features at the particle level that actually hold for the universe as a whole.

3.7.K *Dunning-Davies thermodynamics for antimatter*

As well known, the sole formulation of thermodynamics of the 20-th century was for matter. The first consistent formulation of thermodynamics for antimatter has been reached by J. Dunning-Davies with intriguing implications for astrophysics and cosmology yet to be explored, see the original contribution by Dunning Davies quoted below.

3.7.L *Isoselfdual spacetime machine*

A “spacetime machine” is generally referred to a mathematical process dealing with a closed loop in the forward spacetime cone, thus requiring motions forward as well as backward in time. As such, the “machine” is not permitted by causality under conventional mathematical treatment, as well known.

Santilli discovered that isoselfdual matter, namely, matter composed by particles and their antiparticles such as the positronium, have a null intrinsic time, thus acquiring the time of their environment, namely, evolution forward in time when in a matter field, and motion backward in time when in an antimatter field.

Consequently, Santilli showed that isoselfdual systems can indeed perform a closed loop in the forward light cone without any violation of causality laws, because they can move forward when exposed to a matter and then move backward to the original starting point when exposed to an antimatter.

3.7.M *Original literature*

Santilli’s original papers on the discovery of isomathematics have been identified in Chapter 2. To our best knowledge, Santilli’s first paper on the isodual theory of antimatter is the one dating to 1994 [84] (following the 1993 paper on isodual numbers).

The first presentations of the classical isodual theory, antigravity, the isodual photon and the isoselfdual spacetime machine appeared in papers [85, 86, 98, 111]. An independent study by an experimentalist on the feasibility and resolatory character of the proposed measurements of the gravity of positron in horizontal flight on Earth can be found in paper [173].

Comprehensive presentation of the isodual theory of antimatter are available in the monographs [14, 19]. The first formulation of thermodynamics for antimatter was reached by J. Dunning Davies in paper [199].

3.8 **Initiation of q -Deformations of Lie Theory**

As part of his Ph. D. Thesis at the University of Torino, Italy, Santilli proposed in 1967 [30] the first mutations (today known as “deformations”) of Lie algebras known in the mathematical and physical literature of the time with the product

(where we return to use the conventional notation of the associative product ab)

$$(A, B) = pAB - qBA, \quad (3.30)$$

where AB is the conventional associative product, and $p, q, p \pm q$ are non-null parameters or functions (denotes λ and μ in the original reference). In particular, Santilli stressed in the 1967 paper that that his product (A, B) is jointly Lie-admissible (namely, $(A, B) - (B, A)$ is Lie) and Jordan admissible (namely, $(A, B) + (B, A)$ is Jordan).

The proposal was made as a first approximation of Lagrange and Hamilton's legacy (Section 2.1), namely, via a generalization of the analytic equations approximating external terms for open, nonconservative and irreversible systems while reconstructing an algebra in the brackets of the time evolution.

In fact, in his 1967 paper and others of that period (see Refs. [31,32] and others) Santilli writes the deformed analytic equations in the form

$$\frac{dr}{dt} = p \frac{\partial H(r, p)}{\partial p}, \quad \frac{dp}{dt} = -q \frac{\partial H(r, p)}{\partial r}. \quad (3.31)$$

that, for $p = 1$ and $q = 1 - \varepsilon/(\partial H(r, p)/\partial r)$, Eqs. (3.31) are approximated into the form

$$\frac{dr}{dt} = \frac{\partial H(r, p)}{\partial p}, \quad \frac{dp}{dt} = -\frac{\partial H(r, p)}{\partial r} + \varepsilon, \quad \varepsilon = \text{constant}, \quad (3.32)$$

with nonunitary time evolution of an observable Q in the finite and infinitesimal forms

$$W(t)W(t)^\dagger \neq I, \quad (3.33)$$

$$Q(t) = W(t)Q(0)Q(t)^\dagger = \exp(Hqt)Q(0)\exp(-itpH), \quad (3.34)$$

$$i \frac{dQ}{dt} = (Q, H) = pQH - qHQ, \quad (3.35)$$

thus regaining a consistent algebra in the brackets of the time evolution, while representing, for the first time, nonconservative and irreversible systems. The lack of totally antisymmetric character of the brackets then characterize the time rate of variation of the energy

$$i \frac{dH}{dt} = (H, H) = (p - q)HH \neq 0, \quad (3.36)$$

as well as of other quantities.

In this way, Santilli realized Jordan's dream of seeing his algebras appear in physics applications, although at the level of a covering of quantum mechanics, since the latter has no possible content of Jordan algebras. Santilli also worked out the classical image of the above formulation in which the Lie-admissible character persists, although the Jordan-admissible character is lost.

Santilli's presented his mutations (deformations) of Lie algebra in paper [32] via the most general possible formulation, that in which the product AB is nonassociative, with the clear identification of its associative particular form. Subsequent vast studies in mutations were conducted as part of hadronic mechanics and, as such, they are discussed below.

As it is well known, in 1989 L. Biedernarn and R. Macfairlane published their papers on the simpler q -deformations with product $(A, B) = AB - qBA$ without any quotation of Santilli's origination of 1967 [30], even though they were fully aware of it (Biedenharn joined Santilli in the early 1980s for a DOE grant application precisely on Santilli's mutations/deformations, and Macfairlane was directly informed by Santilli years prior to 1986). In particular, Biedenharn and Macfairlane changed Santillis original, algebraically more appropriate term of "mutations" into "deformations," and avoided the identification of their Lie-admissible and Jordan admissible character to prevent an instantaneous identification of Santilli's origination, due to his known expertise in these algebras.

Following these publications, thousands of papers on q -deformations appeared in the physics literature generally without any quotation of Santilli's origination. As a result of these occurrences, Santilli has been dubbed the most plagiarized physicist of the 20-th century.

3.9 Theorems of Catastrophic Inconsistencies of Noncanonical and Nonunitary Theories

3.9.A The majestic consistency of Hamiltonian theories

Santilli has always considered classical Hamiltonian mechanics and its operator image, quantum mechanics (hereoihereon referred to as "Hamiltonian theories"), as having a majestic consistency, due not only to their mathematical rigor permitted by their underlying Lie's theory and its body of methods, but also to the physical consistency of their axiomatic structure.

Consider the fundamental dynamical equations of quantum mechanics, Heisenberg's equations for the characterization of the time evolution of an observable $Q(t)$ in the finite and infinitesimal forms

$$Q(t) = U(t)Q(0)Q^\dagger(t) = \exp(Hti)Q(0) \exp(-itH), \tag{3.37}$$

$$i \frac{dQ}{dt} = QH - HQ = [Q, H], \tag{3.38}$$

$$H = \frac{p^2}{2m} + V(r) = H^\dagger, \quad Q = Q^\dagger, \tag{3.39}$$

Schrödinger's equations (for $\hbar = 1$)

$$i\partial_t|\rangle = H|\rangle = E|\rangle \tag{3.40}$$

$$p_k| \rangle = -i\partial_k| \rangle, \quad (3.41)$$

and the canonical commutation relations

$$[r^i, p_j] = \delta_j^i, \quad [r^i, r^j] = [p_i, p_j] = 0, \quad i, j, k = 1, 2, 3. \quad (3.42)$$

A most dominant property needed for the majestic consistency is that the time evolution operator $U(t)$ constitutes a unitary transformation when formulated on a Hilbert space over the field of complex numbers,

$$U(t)U^\dagger(t) = U^\dagger(t)U(t) = I. \quad (3.43)$$

The corresponding property for the classical time evolution is that of constituting a canonical transformation, that also preserves the unit.

The implications of the above simple property are far reaching. To begin, the time evolution of quantum mechanics leaves invariant the basic unit, generally assumed to be that of the Euclidean space, $I = \text{Diag.}(1, 1, 1)$,

$$I \rightarrow I' = UIU^\dagger \equiv I. \quad (3.44)$$

But the unit $I = \text{Diag.}(1, 1, 1)$ generally represents in an abstract way units actually used in experiments, such as $I = \text{Diag.}(1 \text{ cm}, 1 \text{ cm}, 1 \text{ cm})$. Consequently, the unitary character of the time evolution law of quantum mechanics implies the preservation over time of the basic units of measurements,

$$I = \text{Diag.}(1 \text{ cm}, 1 \text{ cm}, 1 \text{ cm}) \rightarrow U[\text{Diag.}(1 \text{ cm}, 1 \text{ cm}, 1 \text{ cm})]U^\dagger = \text{Diag.}(1 \text{ cm}, 1 \text{ cm}, 1 \text{ cm}). \quad (3.45)$$

Additionally, a quantity that is an observable (Hermitean) at the time $t = 0$ remains observable at all subsequent times,

$$H = H^\dagger \rightarrow UHU^\dagger = H' = (H')^\dagger. \quad (3.46)$$

Also, if quantum mechanics yields a given numerical prediction, e.g., 57.72 MeV, at a given time, the theory maintains the same numerical prediction under the same conditions at all subsequent times,

$$H| \rangle = 57.72 \text{ MeV}| \rangle \rightarrow U(H| \rangle)U^\dagger = H'| \rangle' = U(57.72 \text{ MeV}| \rangle)U^\dagger = 57.72 \text{ MeV}| \rangle'. \quad (3.47)$$

Finally, the unitarity of the time evolution permits the verification of causality and other physical laws. As a result, quantum mechanics has the majestic feature of preserving over time the units of measurements, the observability of physical quantities, the numerical predictions under the same conditions, causality and other laws. A corresponding physical consistency holds for classical Hamiltonian formulations.

3.9.B Theorems of catastrophic inconsistencies of noncanonical and nonunitary theories

The limitations of Hamiltonian theories in face of the complexity of nature was seen in the last decades of the 20th century by several physicists, resulting in the proposal of a considerable number of generalized theories, much along the development of hadronic mechanics.

However, unlike hadronic mechanics, researchers generalized Hamiltonian formulations on one side, while preserving conventional mathematics, on the other side. A major scientific contribution by Santilli's group has been that of identifying the inconsistencies of generalized theories conceived along these lines, that can be expressed via the following:

THEOREM 3.9A: All theories with a nonunitary time evolution,

$$W(t)W^\dagger(t) \neq I, \tag{3.48}$$

when formulated with the mathematical methods of unitary theories (conventional fields, spaces, functional analysis, differential calculus, etc.) do not preserve said mathematical methods over time, thus being afflicted by catastrophic mathematical inconsistencies, and do not preserve over time the basic units of measurements, Hermiticity-observability, numerical predictions and causality, thus suffering of catastrophic physical inconsistencies.

Mathematical inconsistencies: Let I be the unit of the base field at a given time t . But the time evolution cannot preserve such a unit by definition,

$$I \rightarrow I' = W(t)IW^\dagger(t) \neq I. \tag{3.49}$$

Consequently, said theories lose the base field at subsequent times with the consequential catastrophic collapse of their entire mathematical structure.

Physical inconsistencies: Nonunitary theories do not preserve over time the basic units of measurements, because, from the very definition of a nonunitary transform, we have

$$I = \text{Diag.}(1 \text{ cm}, 1 \text{ cm}, 1 \text{ cm}) \rightarrow W \text{Diag.}(1 \text{ cm}, 1 \text{ cm}, 1 \text{ cm})W^\dagger \neq \text{Diag.}(1 \text{ cm}, 1 \text{ cm}, 1 \text{ cm}); \tag{3.50}$$

Similarly, nonunitary theories do not generally preserve observability over time, because they do not preserve Hermiticity over time in view of the Lopez lemma for which the known Hermiticity condition

$$\langle \psi | \{H | \psi \} \rangle = \{ \langle \psi | H \rangle | \psi \}, \tag{3.51}$$

is mapped under a nonunitary transform into the form

$$W \langle \psi | \{H | \psi \} \rangle W^\dagger = \langle \psi' | T \{H' T | \psi' \} \rangle \neq \{ \langle \psi' | T H' \rangle T | \psi \}, \tag{3.52}$$

$$T = (WW^\dagger)^{-1}, \quad (3.53)$$

due to the general lack of commutativity of H' and T , $H'T \neq TH'$.

Also, nonunitary theories do not admit the same numerical predictions under the same conditions at different times, because, for instance, one can select a nonunitary transform for which

$$H_{t=0}|\psi\rangle = 57.72 \text{ MeV } |\psi\rangle \rightarrow W(H|\psi)W^\dagger = H'_{t>0}|\psi\rangle' = 9,487 \text{ MeV } |\psi\rangle', \quad (3.54)$$

Finally, one of Santilli's graduate students has proved that theories with a nonunitary time evolution violate causality laws and have other catastrophic inconsistencies. Santilli then concludes by saying Nonunitary theories formulated with the mathematics of unitary theories have no mathematical or physical value of any type.

The case for classical noncanonical theories formulated with the mathematics of canonical theories have corresponding, catastrophic, mathematical and physical inconsistencies.

3.9.C Examples of catastrophically inconsistent theories

Numerous theories afflicted by the inconsistencies here considered have been and continue to be developed. Examples of classical catastrophically inconsistent, noncanonical theories are given by:

- 1) Newton's equations with nonselfadjoint (nonpotential) forces;
- 2) Lagrange and Hamilton analytic equations with external terms;
- 3) Lagrange and Hamilton's equations without external terms but with Lagrangians and Hamiltonians of second or higher order (depending on accelerations or its time derivatives);
- 4) Birkhoffian mechanics (even though preserving a Lie structure) because non-canonical;

5) Hamilton-admissible mechanics;

Examples of operator, catastrophically inconsistent nonunitary theories are:

- A) (p, q) -, q -, k - or any other deformations of Lie algebras;
- B) The so-called "deformed quantum mechanics";
- C) The so-called "deformed Lorentz symmetry";
- D) The so-called "deformed special relativity";
- E) Theories with a complex-valued Hamiltonian to represent dissipativity, e.g., in nuclear physics;
- F) The so-called quantum groups;
- G) The so-called "squeezed states";
- H) String theories when including gravitation on a curved space;
- I) Quantum gravity;
- J) Nonunitary statistics, such as that by Prigogine;

K) Supersymmetric models;
 L) The Kac-Moody algebras;
 and others.

The literature also contains a number of additional theories suffering of catastrophic inconsistencies not necessarily connected to nonunitarity, among which we mention theories nonlinear in the wavefunction ψ , namely with eigenvalue equations in Hermitean Hamiltonians of the type

$$H(r, p, \psi)|\psi\rangle = E|\psi\rangle. \quad (3.55)$$

In fact, these theories violate the superposition principle and, consequently, cannot be consistently applied to composite states.

Other catastrophically inconsistent theories are those with a nonassociative enveloping algebra, such as Weinberg's nonlinear theory with a time evolution of the type

$$i\frac{dQ}{dt} = Q \otimes H - H \otimes Q, \quad (3.56)$$

where $Q \otimes H$ is nonassociative, because these theories cannot admit any left and/or right unit, thus lacking the definition over a field, prohibit any measurements, lack any consistent exponentiation to reach finite transforms and have other catastrophic inconsistencies (the scholar not familiar with these occurrences should inspect in detail Chapter 2, see the insistence on conventional, or iso- and geno-associative enveloping algebras, and attempt their nonassociative generalizations).

3.9.D Original literature

Inconsistencies of theories with a nonassociative enveloping algebras were studied in the following paper after an initial suggestion by S. Okubo dating back to 1982 (of which the Foundation failed to identify the related paper until now). The studies were then resumed by A. Jannussis, R. Mignani and R.M. Santilli in 1993 with paper [77]. Additional studies can be located in paper [163].

Lopez's Lemma on the general lack of preservation of Hermiticity-observability under nonunitary time evolutions originated in papers [164, 169].

Santilli then conducted comprehensive studies on the Inconsistency Theorems in papers [106, 112, 116, 119, 120].

3.10 Santilli Relativities (1978)

3.10.A Approximate character of Galilei and special relativity within physical media

As recalled in Chapter 1, Santilli accepts special relativity as being exactly valid in vacuum (exterior dynamical problems), but considers special relativity

as being only approximately valid within physical media such as atmospheres, chromospheres, water, glass, etc. (interior dynamical problems).

Santilli argues that we cannot introduce any inertial reference frame within physical media (evidently because of drag forces), the only reference frame is the privileged frame locally at rest with the medium, and a number of physical media are opaque to light. These conditions prevent any consistent formulation, let alone verification of the very foundations of special relativity.

Note that the No Reduction Theorems of Section 1.1 prevent the regaining of special relativity by reducing interior dynamical systems to elementary particles. Even assuming that said theorems can be bypassed with some hitherto unknown manipulation, it is evidently impossible to introduce microscopic inertial reference systems and measuring apparatus, e.g., in the interior of Jupiter or in core of the Sun.

In view of the above occurrences, Santilli has constructed the mathematical methods reviewed in Chapter 2 for the specific intent of constructing coverings of Galilei and Einstein special relativity for interior dynamical problems, first proposed in volumes [9] and [10] of 1991, and then developed in numerous additional papers and books identified below. The emerging covering relativity are today called Santilli isorelativities in general, and Santilli iso-Galilean relativity and Santilli iso-Einsteinian relativity in particular.

The central tools for Santilli relativity are the coverings of the Galilei and the Lorentz-Poincaré symmetries for interior dynamical systems in reversible conditions as permitted by the Lie-isotopic theories, and for interior dynamical problems in irreversible conditions as permitted by the Lie-admissible theory.

For the particular case of *transparent* [physical media (only)], Santilli's central discovery has been the identification of the *universal symmetry for all locally varying speeds of light*. In essence, the reduction to photons of light propagating within physical media has been discredited because essentially political, since "said reduction does not allow any representation of the angle of refraction of light when passing through the water surface (evidently because photons will scatter in all directions); said reduction does not allow a numerical representation of the large reduction of the speed of light in water of about 1/3 (explicit calculation via photons scattered among the water molecules can at best provide a 7% reduction of speed); and the reduction to photons is evidently meaningless, e.g., for radio waves with lone meter wavelength.

Even assuming that these insufficiencies can be resolved via some unknown manipulation, the propagation of light in water along a straight line requires that a very large number of photons pass through a very large number of nuclei without any scattering or deviation, which is an evident impossibility.

The above and other occurrences, have mandates the return to the conception of light as (as well as photons wavepackets when applicable) as electromagnetic

waves created and propagated by the ether as a universal substratus with extremely high density. The presence of matter then alters the geometry of Minkowskian spacetime resulting in a necessary locally varying speed $bC = c/n$ where n is the local index of refraction. In turn, it is evident that no consistent covering theory can be formulated without first achieving the universal invariance of the locally varying speeds of light.

As recalled in Chapter 1, Santilli accepts as exact the validity of special relativity in vacuum (exterior dynamical problems), but considers it merely approximated within physical media such as atmospheres, chromospheres, transparent liquids, etc. (Interior dynamical problems.)

In fact, Santilli argues that he cannot introduce any inertial reference frame within physical media evidently because of the drag forces; the only reference frame is the privileged frame locally at rest with the medium; and a number of physical media are opaque to light, thus preventing any consistent formulation of the very foundations of special relativity.

On historical grounds we recall that W. Pauli in one of the footnotes of his famous book *Theory of Relativity*, H.A. Lorentz attempted in 1895 the construction via Lie's theory of the symmetry leaving invariant the locally varying speed of light within physical media, $C = c/n$, where c is the speed of light in vacuum and n the familiar index of refraction. However, he encountered unsurmountable difficulties, and had to restrict the study to the constancy of the speed of light in vacuum c , resulting in the now historical paper of 1904 presenting the celebrated *Lorentz symmetry* with connected component $SO(3,1)$.

Santilli studied Pauli's book very carefully, identified the footnote presenting the unsolved problem, and called it the *Lorentz problem*, again, referring to the construction of the symmetry leaving invariant the locally varying speed of light $C = c/n$, such as for light traveling through liquids, atmospheres, chromospheres, etc., and initiated the research for its solution that resulted to be of such a complexity to require a lifetime of study.

By looking in retrospect, Santilli's most important contributions for Lorentz's problem have been:

1) The proof that the problem cannot be solved with Lie's theory because, even assuming that a solution is found empirically, that solution is catastrophically inconsistent in view of the Theorems of Section 3.9;

2) The construction of the iso-, geno- and hyper coverings of Lie's theory and their isoduals permitting indeed the construction of an *invariant* solution for physical media of matter and antimatter, respectively; and

3) Constructing step by step iso-, geno- and hyper- and isodual generalizations of all main aspects pertaining to the Lorentz symmetry, from numbers to special relativity, and proving that said covering theories verify available experimental evidence for the intended conditions of applicability.

Evidently, we cannot possibly review here this lifetime of work. Hence, we have to avoid any review of Santilli iso-Galilean relativity, and restrict ourself to a review of the iso-Einstein relativity, while referring interested colleagues to the original contributions all available in free pdf download. Chapters 5, 6, 7 are devoted to the rather vast experimental verifications in virtually all quantitative sciences.

3.10.B Santilli's opening statement

In seminars delivered at physics departments around the world, Santilli often brings in the lecture room a small rubber ball, a glass filled up with water, a picture of far away galaxies, pictures of Sun light at the Zenith, Sunset and Sunrise, and a cigarette lighter. He then initiated the seminar with the following opening words:

Einstein's special relativity has a majestic axiomatic structure and a truly impressive body of experimental verifications for the conditions of its original conception, point-like particles and electromagnetic waves propagating in vacuum conceived as empty space. In view of these historical successes, it has been widely believed in the 20th century that special relativity is valid for whatever conditions exist in the universe. In reality, there exist numerous conditions, beyond those of the original conception, under which special relativity is only "approximately valid" or "inapplicable" and cannot be claimed to be violated in respect to Albert Einstein, because the theory was not conceived for these broader conditions. Among a variety of these conditions, I bring to your attention the following five cases of visual evidence on the inapplicability of special relativity:

1) *The squeezing of this rubber ball cannot be treated by special relativity or quantum mechanics due to their incompatibility with the deformation theory that would causes the breakdown of the central pillar of both theories, the rotational symmetry. This limitation carries on all the way to hadron physics since protons and neutrons are extended and, therefore, have to be deformable with numerous important implications, for instance, for a quantitative representation of nuclear magnetic moments;*

2) *The simple phenomenon of the refraction of light causing the apparent bending of a stick in this glass of water also cannot be represented with special relativity because the occurrence can be solely represented quantitatively via a decrease of the speed of light in water, thus terminating the belief on the "universal" constance of the speed of light, since its reduction to photons scattering among liquid molecules has been disqualified for lack of quantitative representation of all electromagnetic waves propagating in water, such as for radiowaves with 1 m wavelength for which the reduction to photons has no physical sense;*

3) *When looking at this picture of far away galaxies, special relativity cannot provide any classical distinction between matter and antimatter galaxies since the*

sole distinction admitted by special relativity is that of the sign of the charge while far away galaxies must be assumed to be neutral. At any rate, antimatter did not exist as yet at the time of Einstein's formulation of special relativity;

4) These pictures of Sun light at the Zenith, Sunset and Sunrise constitute evidence visible to the naked eye of the inapplicability of special relativity within physical media such as our atmosphere because the first picture established the transparency of our atmosphere to blue light, thus preventing its absorption at the horizon, while the remaining two pictures establish the existence of a redshift that cannot possibly follow relativity laws because, assuming it exists at Sunset, it cannot exist at Sunrise since Earth moves away from the Sun at Sunset while it moves toward the Sun at Sunrise. Hence, according to special relativity, we should have a distinct redshift at Sunset and an equally distinct blueshift at Sunrise. The dominance of the red at both Sunset and Sunrise, therefore, establishes the existence of a basically new behavior of light propagating within physical media beyond that of light propagating in vacuum;

5) Special relativity and quantum mechanics are inapplicable to energy releasing process, such as the flame in this cigaret lighter, because all energy releasing processes are irreversible over time, while special relativity and quantum mechanics are strictly reversible and consequently predict that the flame and the smoke should recombine themselves spontaneously into the original fuel. In any case, special relativity and quantum mechanics had to be built with reversible axioms as a necessary condition to represent the physical problems in the early part of the 20th century, such as electrons orbiting in an atomic structure. Consequently, special relativity and quantum mechanics cannot credibly be assumed as being valid for the dramatically different irreversible processes.

In this seminar I shall indicate that, thanks to the use of new mathematics specifically constructed for the problems at hand, it is possible to construct sequential coverings of special relativity and quantum mechanics providing a more adequate treatment of the above five physical conditions.

I would like to stress *ab initio* that I do preserve Einstein's axioms and merely present broader realizations. In different words, my way of honoring the memory of Albert Einstein is not that of adapting nature to his original formulations with consequential risk of condemnations by posterity, but instead I honor Einstein by providing a dramatic broadening of the conditions of applicability of his axioms.

In this section we provide an outline of the latter objectives as well as free pdf downloads of Santilli's original contributions at times of difficult identification in the libraries.

3.10.C Conceptual foundations

Santilli always considered the widespread claim of the "universal constancy of the speed of light" a political posture because, as indicated in Section 1.2, the

scientific statement should be “constancy of the speed of light in vacuum,” since that is the sole case with experimental verifications.

Therefore, Santilli never accepted special relativity for the characterization of dynamics within physical media because *most media are opaque to light*. Hence, the assumption of the speed of light *in vacuum* as the maximal causal speed within physical media opaque to light was repugnant to him. He then searched for a geometric characterization that would replace the speed of light within physical media, in such a way to recover, of course, the speed of light when propagation returns to be in vacuum.

Santilli was also unable to accept special relativity for media that are transparent to light, such as liquids, atmospheres, chromospheres, etc., for various reasons. Consider, for instance, the propagation of light in water. In this case electrons can propagate faster than the local speed of light, producing the known Cerenkov light. He argued that, if the speed of light *in vacuum* is assumed as the maximal causal speed *in water* to salvage causality, there is the violation of a fundamental relativistic principle because the sums of two light speeds in water does not yield the speed of light in water. Alternatively, if one assumes the speed of light *in water* as the maximal causal speed, the relativistic addition of speeds is salvaged but special relativity would violate causality.

The usual posture of attempting to salvage special relativity via the reduction of light to photons scattering through atoms was dismissed as political, because such a reduction has no physical value for electromagnetic waves with large wavelength, such as of 1 meter wavelength, which electromagnetic waves also propagate in water at a reduced speed according to the law $C = c/n$.

By keeping these aspects in mind and their experimental verifications established in Chapter 5, *the biggest physical implications of Santilli's studies is that matter causes a mutation of the very structure of conventional Minkowskian spacetime*. In any case, deviations from Einsteinian predictions within matter could not exist without such a mutation.

Along the latter lines, by far the biggest deviations from special relativity are expected by Santilli within *physical media that are inhomogeneous (due to a local change of density) and anisotropic (due to differences in different space directions)* such as atmospheres, chromospheres, etc., because these media have *geometric deviations* from the homogeneity and isotropy of the Minkowski spacetime.

In studying the original contributions, interested scholars are, therefore, suggested to pay particular attention to the interplay between geometry, algebras and physics.

3.10.D Mathematical foundations

The problem solved by Lorentz was the invariance of the Minkowskian metric $m = \text{Diag.}(1, 1, 1, -c^2)$. The problem solved by Santilli was the invariance of the broader metric $\hat{m} = \text{Diag.}(1, 1, 1, -c^2/n^2)$, where n is a rather complex function of all needed local variables. It is evident that the latter metric can be solely connected to the former via a *noncanonical* transformation at the classical level or a *nonunitary* transform at the operator level. Assuming this main characteristic also assures the exiting from the class of equivalence of the Lorentz symmetry.

Hence, Santilli considered the noncanonical transform of m into the most general possible diagonal metric \hat{m} with signature $(+, +, +, -)$

$$m = \text{Diag.}(1, 1, 1, -c^2) \rightarrow \hat{m} = \text{Diag.}(1/n_1^2, 1/n_2^2, 1/n_3^2, -c^2/n_4^2) = Tm, \quad (3.57)$$

where the index of refraction $n = n_4$ is extended to all components because generated by the mere application of Lorentz transforms or other symmetrization processes.

The n 's are called the *characteristic quantities* of the medium considered. The *inhomogeneity* of the medium is represented via a dependence of the n 's on the local density μ , the local temperature τ , etc., $n_k(r, \mu, \tau, \dots)$, $k = 1, 2, 3, 4$, while the *anisotropy* is represented by differences between the space and time characteristics quantities. All n 's are normalized to the value $n_k = 1$, $k = 1, 2, 3, 4$, for the vacuum. Additional information on the characteristic quantities have been provided in Section 2.4.

Santilli then looked for the symmetry of the most general possible, symmetric line element in $(3 + 1)$ dimension with signature $(+, +, +, -)$

$$\hat{r}^2 = ((r^1)^2/n_1^2 + (r^2)^2/n_2^2 + (r^3)^2/n_3^2 - t^2 c^2/n_4^2) \hat{I}, \quad n_k > 0, \quad k = 1, 2, 3, 4, \quad (3.58)$$

with isotopic element and isounit the expressions

$$T = \text{Diag.}(1/n_1^2, 1/n_2^2, 1/n_3^2, 1/n_4^2) > 0, \quad (3.59)$$

$$\hat{I} = 1/T = \text{Diag.}(n_1^2, n_2^2, n_3^2, n_4^2) > 0. \quad (3.60)$$

Santilli then:

1) Formulated the theory on his iso-Minkowskian space $\widehat{M}(\hat{r}, \hat{\times}, \hat{I})$ (Section 2.6) with isocoordinates $\hat{r} = r\hat{I}$, $r = (r^1, r^2, r^3, t)$, with isoassociative product $A\hat{\times}B = ATB$ over an isofield \hat{F} with isounit \hat{I} ;

2) Identified the noncanonical transform with the isounit

$$W \times \widehat{W} = \hat{I}, \quad (3.61)$$

$$(W \times W^\dagger)^{-1} = T; \quad (3.62)$$

where † evidently represents transposed for real values matrices; and

3) Subjected to the above noncanonical transform the totality of the framework of special relativity, from numbers to physical laws, with no exclusion to avoid catastrophic inconsistencies due to mixing the mathematics of the covering theory with that of the old.

The above assumptions are sufficient to construct the desired symmetry in the most rigorous possible, but also an elementary way. In fact, the indicated use of the noncanonical transforms permits the simple construction of: the isonumbers

$$n \rightarrow \hat{n} = Wn\widehat{W} = n(W\widehat{W}) = n\widehat{I}; \quad (3.63)$$

the isoproduct

$$nm \rightarrow W(nm)\widehat{W} = (Wn\widehat{W})(WW^\dagger)^{-1}(WmW^\dagger) = \hat{n}T\hat{m} = \hat{n}\widehat{\times}\hat{m}; \quad (3.64)$$

the isoexponentiation to the right and to the left for a given Lorentz generator J with related parameter w

$$\exp(Jw \times i) \rightarrow W \times [\exp(Jwi)]W^\dagger = [\exp(JTwi)]\widehat{I}, \quad (3.65)$$

$$\exp(-iwJ) \rightarrow W[\exp(-iwJ)]W^\dagger = \widehat{I}[\exp(-iwTJ)]; \quad (3.66)$$

and the consequential isotopy of the finite Lorentz transformations of a physical quantity $Q(w)$

$$Q(w) = [\exp(Jwi)]Q(0)[\exp(-iwJ)] \rightarrow \quad (3.67)$$

$$\rightarrow W\{[\exp(Jwi)]Q(0)[\exp(-iwJ)]\}W^\dagger =$$

$$\rightarrow [\exp(JTwi)]\widehat{Q}(0)[\exp(-iwTJ)]. \quad (3.68)$$

All remaining needed isomathematics can be constructed in the same elementary way. The isodual formalism for antimatter is derived via the simple isodual transform (2.9) applied to the totality of the isotopic methods (see Section 2.7 for formal treatments).

3.10.E Invariance and universality of Santilli's isotopies

It is easy to see that the isotopic formalism of the preceding section is *not* invariant under both canonical and noncanonical (or unitary and nonunitary) transforms, such as

$$ZZ^\dagger \neq I, \quad (3.69)$$

because the above transform does not leave invariant the basic isounit:

$$\widehat{I} \rightarrow \widehat{I}' = Z\widehat{I}Z^\dagger \neq \widehat{I}, \quad (3.70)$$

with consequential lack of invariance of the isoproduct

$$A \widehat{\times} B = ATB \rightarrow Z(A \widehat{\times} B)Z^\dagger = (ZAZ^\dagger)(Z^{\dagger-1}TZ^{-1})(ZBZ^\dagger) = A'T'B', T' \neq T. \quad (3.71)$$

The above lack of basic invariances activates Theorem 3.9A with catastrophic mathematical and physical inconsistencies that should have been expected due to the mixing of isotopic methods formulated on isospaces over isofields with conventional transformations formulated on conventional spaces over conventional fields.

It is easy to see that, if the above noncanonical or nonunitary transform is reformulated according to Santilli isomathematics, full invariance is reached and Theorem 3.9A is bypassed. In fact, all noncanonical or nonunitary transforms can be *identically* reformulated in the isotopic form $Z = \widehat{Z}T^{1/2}$, under which they become *isocanonical or isounitary transforms*, namely, they reconstruct canonicity or unitarity on isospaces over isofields,

$$Z = \widehat{Z}T^{1/2}, \quad ZZ^\dagger = \widehat{Z}T\widehat{Z}^\dagger = \widehat{Z} \widehat{\times} \widehat{Z}^\dagger = \widehat{Z}^\dagger \widehat{\times} \widehat{Z} = \widehat{I}. \quad (3.72)$$

It is easy to see that Santilli's isotopic formalism is indeed invariant under the above isocanonical or isounitary transforms. In fact, we have the invariance of the isounit

$$\widehat{I} \rightarrow \widehat{I}' = \widehat{Z} \widehat{\times} \widehat{I} \widehat{\times} \widehat{Z}^\dagger = \widehat{Z} \widehat{\times} \widehat{Z}^\dagger \equiv \widehat{I}. \quad (3.73)$$

Similarly, we have the invariance of the isoproduct

$$\widehat{A} \widehat{\times} \widehat{B} \rightarrow \widehat{Z} \widehat{\times} (\widehat{A} \widehat{\times} \widehat{B}) \widehat{\times} \widehat{Z}^\dagger = \widehat{A}' \widehat{\times} \widehat{B}', \quad (3.74)$$

namely, the isotopic element T remains unchanged. The invariance of all remaining operations then follow and Theorem 3.9A is bypassed.

The scholar serious in science should be aware that the regaining of invariance for noncanonical and nonunitary theories has been the very reason for Santilli laborious and momentum discovery and development of his isomathematics.

It is important also to know that *Santilli's isotopies of the Minkowskian geometry are "directly universal" in the sense that they admit all infinitely possible mutations of the Minkowski spacetime (universality) directly in the isometric without any need for coordinates transformations (direct universality).*

Finally, the reader should keep in mind that Santilli's isospecial relativity (see below) represents dynamical systems with the conventional Hamiltonian (for all potential interactions) and the isounit (for non-Hamiltonian interactions). Consequently, *the change of the isounit causes the transition to a different physical system.* That is the reason for fixing the isounit in actual applications.

3.10.F Lorentz-Poincaré-Santilli isosymmetry and its isodual

Following, and only following the above laborious preparatory advances, including the achievement of the crucial invariance, it was easy for Santilli to construct the isotopies of the Lorentz and Poincaré symmetry, today known as *Lorentz-Poincaré-Santilli isosymmetry* or at times *Poincaré-Santilli isosymmetry*.

For clarity and simplicity, in this section we shall outline the *projection* of the isosymmetry in our spacetime. Thus, we shall avoid using the the symbol “ \times ” to denote conventional multiplication; we shall use the isomultiplication $A\hat{\times}B = ATB$ when necessary; ordinary symbols J, P , etc., will indicate quantities belonging to the Poincaré symmetry; while symbols with a hat will indicate quantities belonging to isospaces over isofields. To begin, the connected component of the Lorentz-Poincaré-Santilli isosymmetry can be written

$$\hat{P}_{11}(3.1) = [\widehat{SO}_6(3.1) \otimes \widehat{T}_4(3.1)] \times \widehat{T}_1, \quad (3.75)$$

and comprises: the six-dimensional *Lorentz-Santilli isosymmetry* $\widehat{SO}_6(3.1)$; the four-dimensional *isotranslations* $\widehat{T}_4(3.1)$ in the isoparameters $\hat{a} = a\hat{I}$; and the novel one-dimensional *isotopic isotransform* \widehat{T}_1 in the isoparameters $\hat{w} = w\hat{I}$ identified below, thus being *eleven (rather than ten) dimensional*, with conventional generators

$$\hat{p}_{11}(3.1) = \{J_{ij}, P_k, Q\}, \quad i, j, k = 1, 2, 3, 4, \quad (3.76)$$

Lie-Santilli isocommutation rules in terms of isoproduct (2.26),

$$[J_{ij}\hat{,}J_{pq}] = i(\hat{m}_{jp}J_{iq} - \hat{m}_{ip}J_{jq} - \hat{m}_{jq}J_{ip} + \hat{m}_{iq}J_{jp}), \quad (3.77)$$

$$[J_{ij}\hat{,}P_k] = i(m_{ik}P_j - m_{jk}P_i), \quad (3.78)$$

$$[P_{ij}\hat{,}P_{ij}] = [J_{ij}\hat{,}Q] = [P\hat{,}Q] = 0, \quad (3.79)$$

Casimir-Santilli isoinvariants

$$\hat{C}_0 = \hat{I}, \quad (3.80)$$

$$\hat{C}_2 = P_k\hat{\times}P^k, \quad (3.81)$$

$$\hat{C}_4 = \hat{L}_k\hat{\times}\hat{L}^k, \quad \hat{L}_k = \varepsilon_{ijpq}J^{jp}\hat{\times}P^k, \quad (3.82)$$

and isotransforms;

- 1) *Isorotations* (see the references for details),

$$\mathbf{r}' = \hat{R}(\boldsymbol{\theta})\mathbf{r}; \quad (3.83)$$

- 2) *Isoboosts* here presented for motion in the conventional (3, 4) plane

$$r'^1 = r^1, \quad r'^2 = r^2, \quad (3.84)$$

$$r'^3 = \hat{\gamma}[r^3 - \hat{\beta}r^4(n^3/n^4)], \quad (3.85)$$

$$r'^4 = \hat{\gamma}[r^4 - \hat{\beta}r^3(n^4/n^3)], \quad (3.86)$$

$$\hat{\gamma} = 1/(1 - \hat{\beta})^{1/2}, \quad \hat{\beta} = (v/n_3)/(c/n_4), \quad (3.87)$$

where v is the speed along the third axis;

3) *Isotranslations*,

$$r'^k = r^k + A^k(a, \dots), \quad (3.88)$$

$$A^k = a^k[\hat{m}_{kk} + [\hat{m}_k, P_k]/1! + \dots] \text{ (no sum)}; \quad (3.89)$$

4) *Isotopic transform*

$$\hat{m} \rightarrow \hat{m}' = w\hat{m}, \quad \hat{I} \rightarrow \hat{I}' = w^{-1}\hat{I}, \quad (3.90)$$

under which isoline element (3.58) remains indeed invariant.

In summary, recall that the Poincaré symmetry is *ten* dimensional. Contrary to all expectations, Santilli's isotopies of the Poincaré symmetry turned out to be *eleven* dimensional. Hence, Santilli conducted a re-examination of the conventional treatment of special relativity.

The basic unit of the Lorentz and Poincaré symmetries is the 4-dimensional unit matrix $I = \text{Diag.}(1, 1, 1, 1) > 0$, while the unit of the base field universally assumed in special relativity is the trivial unit $+1$. To avoid this disparity, Santilli assumed the same unit for both the symmetry and the base field, thus using a basic field with unit I . Thanks to his discovery of the isonumber theory, this assumption requires to rewrite scalars from the usual form w , into the isoscalar form $\hat{w} = wI$ (see Chapter 2). Consequently, one is forced to rewrite the basic invariant of special relativity in the form

$$r^2 = (r^\dagger m r)I = ((r^1)^2 + (r^2)^2 + (r^3)^2 - t^2 \times c^2)I, \quad (3.91)$$

where $r = (r^k)$, $k = 1, 2, 3$, and $r^4 = t$.

These simple steps allowed the discovery that *the Poincaré symmetry is eleven dimensional, rather than ten dimensional as popularly believed in the 20th century*, in view of the additional one-dimensional isotopic invariance

$$(r^\dagger m r)I \equiv [r^\dagger(wm)r](w^{-1}I) = (r^\dagger \hat{m} r)\hat{I}. \quad (3.92)$$

Since all spacetime symmetries have important physical applications, the same holds for the isotopic symmetry. In fact, the new symmetry allowed Santilli to reach a basically new grand unification of electroweak and gravitational interactions, as we shall see later on.

Note that m and \hat{m} have the same signature $(+, +, +, -)$. Following the above reformulation of the conventional symmetry, we can quote the following

LEMMA 3.10A: The Poincaré-Santilli and the Poincaré symmetries are isomorphic.

The above lemma illustrates Santilli's achievement of broader realizations of the abstract axioms of special relativity. The *isodual Poincaré-Santilli isosymmetry* for antimatter can be easily constructed via isoduality.

The isotopies of the spinorial covering of the Lorentz-Poincaré' symmetry were constructed by Santilli in 1995 and are presented in Section 3.11Q.

Note that the new isotopic symmetry (3.92) remained undiscovered for close to one century. This should not be surprising because its discovery required the prior discovery of new numbers, the isonumbers with an arbitrary unit. Note also from the direct universality of the isotopies, the Poincaré-Santilli isosymmetry provides the invariance for all possible line elements with signature $(+, +, +, -)$, including the Riemannian, Finslerian, Non-Desarguesian and other line elements, by including, as the simplest possible case, the Minkowski line element.

3.10.G Santilli isorelativity and its isodual

Thanks to all the preceding mathematical and physical advances, Santilli has conducted a step-by-step isotopic lifting of the physical laws of special relativity resulting in a new theory today known as *Santilli isorelativity*. His central assumption is, again, *the preservation under isotopies of the original axioms by Einstein and the introduction of broader realizations*. This basic assumption was realized to such an extent that special relativity and isorelativity coincide at the abstract, realization-free level and, consequently, they could be presented with the same equations only subjected to different realizations of the symbols.

The above conception is evidently permitted by Lemma 3.10A and carries far reaching physical and experimental implications because any criticism on the structure and applications of isorelativity is a criticism on Einstein's axioms, as we shall indicated later on.

Assume for simplicity that motion occurs in the $(3, 4)$ -plane. Then, inhomogeneity of the medium is represented by a functional dependence of n_3 on the local density, temperature, etc., $n_3 = n_3(r, \mu, \tau, \dots)$. Anisotropy of the medium is expressed by the possible difference $n_3 \neq n_4$. Assume that motion is restricted in the $(3, 4)$ -plane, isorelativity can be presented via the following isoaxioms presented in their projection in our spacetime with conventional multiplication:

ISOAXIOM I: The maximal causal speed within physical media is given by

$$V_{\max} = c(n_3/n_4); \quad (3.93)$$

ISOAXIOMS II: The isorelativistic addition of speeds within physical media is set by the law

$$V_{\text{tot}} = (v_1 + v_2)/(1 + \hat{\gamma}^2); \quad (3.94)$$

ISOAXIOM III: Within physical media, time dilation, length contraction, and variation of mass with speed follow the isotopic laws

$$t = \hat{\gamma}t_o, \tag{3.95}$$

$$d = \hat{\gamma}^{-1}d_o, \tag{3.96}$$

$$m = \hat{\gamma}m_o; \tag{3.97}$$

AXIOM IV: Within physical media the variation of light frequency with speed follows the Doppler-Santilli isotopic law, here written for simplicity for 90° aberration angle as well as in expansion to first order

$$\hat{\omega} = \hat{\gamma}^{-1}\omega_o \approx \omega_o[1 - \gamma(n_4/n_3) + \gamma^2(n_4/n_3)^2/2 + \dots]; \tag{3.98}$$

ISOAXIOM V: Within physical media the energy equivalence of the mass follows the isotopic law

$$E = mV_{\max}^2. \tag{3.99}$$

COMMENTS: Note that the maximal causal speed is set by the geometry of the medium, namely, by the difference between the space and time characteristic quantities representing the anisotropy. As such, V_{\max} can be bigger, equal or smaller to the speed of light in vacuum. In particular, for isotropic media, $V_{\max} = c$.

The Doppler-Santilli isoshift admits the following three cases:

1) The **isoredshift**, namely, a shift toward the red bigger than that predicted by special relativity, generally occurring in anisotropic media of low density, such as planetary atmospheres or astrophysical chromospheres, with values from Eq. (3.98) n_4/n_3 bigger than 1, and V_{\max} smaller than c , essentially characterizing the *release* of energy by light to the medium with consequent *decrease* of the frequency beyond the value predicted by special relativity;

2) The **isoblueshift**, namely, a shift toward the blue bigger than that predicted by special relativity, occurring for in anisotropic media of high density, such as astrophysical chromospheres, with values from Eq. (3.98) n_4/n_3 smaller than 1, and V_{\max} bigger than c , essentially characterizing the *absorption* of energy by light from the medium with consequent *increase* of the frequency beyond the value predicted by special relativity;

3) The **conventional Doppler's shift**, occurring in transparent isotropic media such as water with $n_4/n_3 = 1$.

As we shall see in Chapter 5, the above prediction of Santilli's isorelativity are indeed verified by all available experimental data. Their implications are rather deep because they imply that, e.g., light is expected to exit a star or, much equivalently, a high energy scattering region, at a frequency *bigger* than that of its origination, while light is expected to leave planetary atmospheres or astrophysical chromospheres at a frequency *smaller* than that of its origination.

The celebrated equivalence principle $E = mc^2$ is experimentally verified only for *point-like particles moving in vacuum*. The isoequivalence principle expresses expected differences in excess or in defect from the conventional equivalence principle depending on said anisotropic ratio, said differences being merely due to processes of acquisition of release of energy to the medium.

3.10.H Santilli's isogravitation and its isodual

As indicated in Section 2.6, one of Santilli's most important mathematical contributions has been the *geometric unification of the Minkowskian and Riemannian geometries into the Minkowski-Santilli isogeometry*. This unification has evidently been done as the premise for the unification of special and general relativities. In fact, Santilli's isorelativity is unique in the sense that it incorporates both the special and the general relativity.

As indicated earlier, isotopic line elements (3.58) include as particular cases all infinitely possible (nonsingular) Riemannian line elements. Hence, *Santilli first contribution in gravitation has been the construction of a universal "symmetry of gravitation"*, in lieu of the 20-th century "covariance".

The *isominkowskian formulation of exterior gravitation* is elementary. Any nonsingular Riemannian metric $g(r)$ always admit the decomposition into the Minkowski metric $m = \text{Diag.}(1, 1, 1, -c^2)$ and a 4×4 dimensional positive-definite matrix $T_{gr}(r)$ called *gravitational isotopic element* because it incorporates all gravitational features. Santilli then assumes for basic isounit of exterior gravitation the inverse of T_{gr} ,

$$g(r) = T_{gr}(r)m, \quad \widehat{I}_{gr} = 1/T_{gr}. \quad (3.100)$$

The entire formalism of the Minkowski-Santilli isogeometry then applies, including the *identical reformulation of the Einstein-Hilbert field equations*, although completed with sources as in Section 3.4.

The implications of the above discovery are far reaching and affect all quantitative sciences from classical mechanics to astrophysics. To begin, the formulation avoids the Theorems of Catastrophic Inconsistencies of Section 3.9 thanks to the *invariance* of isogravitation under the Poincaré-Santilli isosymmetry. The same also allows an axiomatically consistent operator formulation of gravity and grand unification, the sole known to the Foundation as being consistent.

As it is well known, all distinctions between exterior and interior gravitation were eliminated in the 20th century for the evident intent of adapting nature to Einstein doctrines. This manipulation of science was done via the claim that interior problems can be reduced to a set of point-like particles under sole action at a distance, potential interactions. As an illustration of this political profile, Schwartzchild wrote two papers, one for the exterior and one for the interior gravitation. The former has been widely acclaimed in the 20th century, while

the latter has been vastly ignored, evidently because the former (latter) was compatible (incompatible) with Einstein's gravitation under a serious scrutiny.

Theorem 1.1 terminates these political postures and sets the origin of macroscopic nonpotential and irreversible effects at the ultimate level of particles at short mutual distances, as a consequence of which the inequivalence of interior and exterior problems are established beyond doubt. Any dissident view should prove that light behaves in the same fashion in the exterior and interior problems, thus believing that electromagnetic waves propagates within atmospheres at the same speed as in vacuum and, additionally, light penetrates all the way to the center of astrophysical masses at the same speed as that in vacuum, which is a nonscientific posture.

For instance, the treatment of a spaceship during re-entry in atmosphere via Einstein's gravitation would be a manifest scientific politics due to the Lagrangian character of the former and the strictly non-Lagrangian nature of the latter. In particular, the resistive forces experienced by the spaceship during re-entry is set by Theorem 1.1 to occur at the level of deep mutual penetration of the peripheral atomic electrons of the spaceship and those of the surrounding atmosphere, with ensuing nonlinear, nonlocal and nonpotential interactions.

Santilli has provided the only known axiomatically correct formulation of *interior isogravitation* that is permitted by the complete absence of restrictions in the functional dependence of the Minkowski-Santilli isometric \hat{m} , thus allowing for the first time in scientific history to introduce in the interior problem the local speed of light, density, temperature, and other crucial features of the interior gravitational problem whose quantitative treatment is inconceivable in general relativity due to the excessive limitations of the Riemannian geometry.

For instance, consider any desired Riemannian metric for the exterior problem, e.g., for the exterior Schwartzchild's solution, with diagonal elements

$$g(r) = (g_{kk}) = \text{Diag.}[(1 - 2m/r)^{-1}, (1 - 2m/r)^{-1}, (1 - 2m/r)^{-1}, -(1 - 2m/r)]. \quad (3.101)$$

Then, a simple lifting of such an exterior metric to the interior problem is given by the following forms where the characteristic quantities depend on local coordinates, r , density μ , temperature τ , etc.,

$$g(r, \mu, \tau, \dots) = \text{Diag.}(g_{11}/n_1^2, g_{22}/n_2^2, g_{33}/n_3^2, g_{44}/n_4^2)\hat{E} = T_{gr}(r, \mu, \tau, \dots)m. \quad (3.102)$$

Following, and only following a more credible representation of interior gravitational problems, Santilli presented *gravitational singularities as the zeros of the time component of the gravitational isotopic element or the infinities of the space*

components of the gravitational isounit,

$$\text{Gravitational Singularities : } \widehat{I}_4^4 \rightarrow \infty, \widehat{I}_k^k \rightarrow 0, k = 1, 2, 3, \quad (3.103)$$

as one can verify via Eq. (3.101). By recalling the physical meaning of the characteristic quantities, one can then see the direct geometric representation of the singularity as follows:

A) The limit $T_k^k \rightarrow 0$, $k = 1, 2, 3$, directly represents the volume of the star being reduced (geometrically) to a point (because said components are the units of space dimensions; and

B) The limit $\widehat{I}_4^4 \rightarrow \infty$ represents the complementary occurrence for which time becomes infinite (because said component is the unity of time) or, equivalently, there is no dynamical evolution, thus preventing the release of light and mass once absorbed.

It is evident that the above features represent, by far, the most elegant and mathematical representations of gravitational collapse in history, to the Foundation best knowledge. However, as stressed by Santilli, this geometric limit is a consequence of the widespread trend in the 20th century of studying extreme *interior* conditions, such as gravitational collapse, with the use of *exterior* gravitation. By comparison, when gravitational collapse is studied more seriously via interior gravitation, it is possible to show that the collapse of a star to a point becomes impossible, while preserving the crucial features of a black holes, such as that of not releasing light or mass.

The experimental verification of Santilli isogravity is assured by the identical reformulation of the Einstein-Hilbert field equation. However, *isogravitation occurs in a flat space since the Minkowski-Santilli isospace is locally isomorphic to the Minkowski space and its curvature is null*. This confirms the viewpoint expressed in Chapter 1 according to which the Riemannian formalism provides a very elegant *mathematical* representation of data, but space cannot be curved in a real sense because curvature cannot explain the weight of stationary bodies, the free fall of bodies along a straight radial line, the bending of light (that is a Newtonian event), and other features.

Alternatively, Santilli has established beyond doubt that the continued insistence on space as being actually curved directly causes: the activation of the Theorems of Catastrophic Inconsistencies; the mandatory need to revise quantum electrodynamics (Section 2.4); the impossibility of reaching a consistent operator form of gravity; the impossibility of achieving a serious grand unification of electroweak and gravitational interactions; and other shortcomings of historical proportions.

3.10.I *Santilli's geno- and hyper-relativities and their isoduals*

As indicated in Chapter 1, Santilli considers irreversibility a fundamental feature of nature originating at the ultimate particle level in view of Theorem 1.1. Isorelativity is structurally reversible and, therefore, it is considered a mere preparatory step toward more fundamental relativities.

It should be indicated that isorelativity has the capability of representing irreversibility via time-dependent isotopic elements $T(t, r, p, E, \dots) = T^\dagger(t, \dots)$ in such a way that $T(t, r, \dots) \neq T(-t, \dots)$. However, this is a somewhat limited representation of irreversibility. In fact, isorelativity was primarily constructed to characterize closed-isolated composite systems that are stable, such as protons, thus being reversible in time, yet possessing non-Hamiltonian internal effects represented with the isounit.

The achievement of a relativity truly capable of representing irreversibility required Santilli to construct his *Lie-admissible genomathematics* and its multi-valued hyper-extension, that are structurally irreversible in the sense that they are irreversible for all possible reversible Hamiltonians. Once such a mathematics was available, new relativities followed, today known as *Santilli geno- and hyper-relativities for matter and their isoduals for antimatter*. We regret our inability to outline these broader relativities to prevent a prohibitive length, as well as a substantial increase in complexity of thought, realization and verification.

3.10.J *Isotopic reconstruction of exact spacetime symmetries when conventionally broken*

The physics of the 20th century saw a rather popular interest in “symmetry breakings” for both spacetime and internal symmetries. Santilli has shown that such “breakings” are due to the use of insufficient mathematics because, when the problem at hand is treated with a more appropriate mathematics, the symmetry is reconstructed exactly and no breaking occurs.

The reconstruction of the exact $SU(2)$ -isospin and $SU(3)$ -color symmetries will be reviewed in Chapter 5. Here we indicate Santilli's mechanism for the exact symmetry reconstruction for the case of spacetime symmetries. Consider the perfect sphere of radius 1 defined on the Euclidean space over the reals R and its known symmetry under the rotational group $SO(3)$,

$$r^2 = r_1^2 + r_2^2 + r_3^2 = 1 \in R. \quad (3.104)$$

Suppose that the above perfect sphere is elastic and experiences a deformation into an ellipsoid of the type

$$r^2 = r_1^2/n_1^2 + r_2^2/n_2^2 + r_3^2/n_3^2 \neq 1. \quad (3.105)$$

It is evident that, when continued to be defined on the Euclidean space over the reals, the above deformation causes the breaking of the rotational symmetry

$SO(3)$. Santilli principle of reconstruction of the exact rotational symmetry is based on the deformation of the line element

$$r^2 = r_1^2 + r_2^2 + r_3^2 \rightarrow r_1^2/n_1^2 + r_2^2/n_2^2 + r_3^2/n_3^2, \quad (3.106)$$

while jointly submitting the basic unit of the Euclidean space $I = \text{Diag.}(1, 1, 1)$ to the *inverse* deformation

$$E = \text{Diag.}(1, 1, 1) \rightarrow \widehat{I} = \text{Diag.}(n_1^2, n_2^2, n_3^2). \quad (3.107)$$

It is then easy to see that the definition of the deformation on the Euclid-Santilli isospace with isounit \widehat{I} recovers a perfect sphere called *isosphere*,

$$\widehat{r}^2 = (r_1^2/n_1^2 + r_2^2/n_2^2 + r_3^2/n_3^2)\widehat{I} \in \widehat{R}. \quad (3.108)$$

In fact, if one semiaxis is deformed of the amount $1/n_k^2$, but the corresponding unit is deformed of the inverse amount n_k^2 , the numerical value of the semiaxes on isospace over isofields remains 1, with the resulting exact isosymmetry $\widehat{SO}(3)$. But the latter symmetry is isomorphic to the conventional one $SO(3)$, thus yielding an exact reconstruction of the rotational symmetry, merely formulated with a more appropriate mathematics.

The reconstruction of the exact Lorentz symmetry when believed to be broken is intriguing. The admission of a locally varying speed of light causes the loss of the light cone within physical media. However, as it is the case for the isosphere, the mutations of spacetime coordinates occur under a joint inverse mutation of the related unit. This process yields *Santilli's light isocone* which is the perfect cone in isospace over isofield, but whose projection on conventional space over the conventional field yields a highly mutated cone whose shape changes in time. The preservation of Einstein's axioms as well as the local isomorphism of the Lorentz-Santilli and the conventional Lorentz symmetry are crucially dependent on the exact reconstruction of the light cone on isospace over isofields with the consequential exact reconstruction of the Lorentz symmetry.

The reconstruction of exact discrete spacetime symmetries is handled in essentially the same manner, thus voiding the 20th century belief that spacetime symmetries are broken.

3.10.K Experimental verifications

In the arena of its applicability (dynamics within physical media or particles in conditions of deep mutual penetration), *Santilli isorelativity has experimental verifications in classical physics, particle physics, nuclear physics, superconductivity, chemistry, astrophysics and cosmology* (see the literature for quantitative treatments). Some of these verifications will be outlined in Section 3.12 and chapter 5.

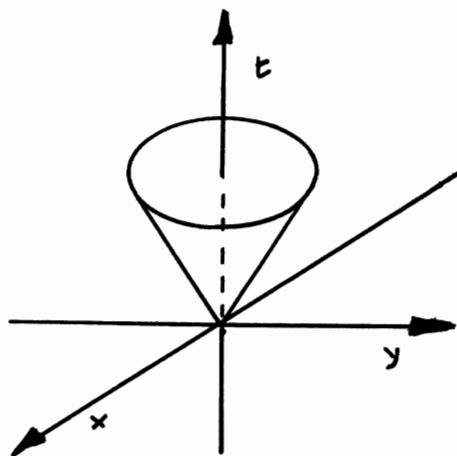

Figure 3.8. The understanding of Santilli isorelativity and its particular realization as isogravitation, requires a knowledge of the *light isocone*, which is the perfect light cone, but defined on the Minkowski-Santilli isospace over Santilli's isonumbers. This deceptive simplicity hides in reality very deep implications. To begin, the projection of the isocone in the conventional spacetime characterizes a locally varying speed of light with consequential highly deformed cone. Hence, Santilli's isotopies reconstruct on isospaces over isofield the exact light cone when no longer applicable in our spacetime. This exact reconstruction is at the foundation of the preservation of the axioms of special relativity for dramatically broader physical conditions, as well as the reconstruction of the exact Lorentz symmetry when popularly believed to be broken. Additionally, *Santilli's isocone permits a direct geometrization of gravitation without curvature*. In fact, the deviations from the perfect light cone can be due to gravitation, and be characterized by the components of, e.g., Schwarzschild's metric (3.101). But each of these deviations is referred to a unit that is its inverse. Ergo, all Riemannian metrics can be reduced to Santilli's isocone with implications, as we shall see, way beyond conventional gravitational studies, such as for the scattering theory, nuclear events, and others, all permitted by the elimination of curvature.

An illustrative experimental verification of isorelativity in classical physics is given by electromagnetic waves propagating in water. In this case, the speed of light is given by $C = c/n_4$, but the medium is homogeneous and isotropic, as a result of which $V_{\max} = c$, thus allowing electrons to travel faster than the local speed of light and verifying causality, as well as the isorelativistic sum of speeds. A similar case occurs for Newton's diffraction of light, and numerous other cases in which there is a deviation of the speed of light from that in vacuum.

An illustrative experimental verification in particle physics is given by the Bose-Einstein correlation outlined in Chapter 5, and other relativistic events in particle physics conventionally treated via the use of ad hoc parameters fitted from the data (and then claim that special relativity is exactly valid!). These parameters

are eliminated in isorelativity and replaced with measurable quantities, such as size of particles, their density, etc. The most important verification in particle physics is the numerically exact representation of all characteristics of neutrons in their synthesis from protons and electrons as occurring in stars, which synthesis, as indicated in Chapter 1, admits no treatment at all via special relativity (see Chapter 5 for details).

An illustrative experimental verification in nuclear physics is given by nuclear magnetic moments that can be solely represented in an exact way via a deformation of charge distributions of protons and neutrons when members of a nuclear structure. These deformations are absolutely impossible for special relativity, but readily admitted by its covering isorelativity. Numerous other verifications also exist in nuclear physics (see Chapter 5 for details).

An illustrative experimental verification in astrophysics is given by the exact representation of dramatically different redshifts of galaxies and quasars when physically connected according to gamma spectroscopy, which representation is permitted by Santilli isoredshift indicated above. For additional verifications, the serious scholar is suggested to consult the specialized literature.

Unfortunately, we have an unreassuring situation in the experimental verification of Einsteinian doctrines for conditions beyond those of their original conception. As Santilli puts it:

Following some fifty years of active research on fundamental open problems, it is my documented view that theories in physics are nowadays established by organized academic consensus and definitely not by a serious scientific process.

In fact, the consideration, let alone the conduction, of systematic experimental tests of Einsteinian theories, under conditions they were not intended for, is nowadays impossible at any major physics laboratory around the world. When limited tests are conducted, Einsteinian doctrines are studiously recovered via the use of arbitrary parameters and their fit from experimental data, while in reality these arbitrary parameters are a direct measure of the "deviations" from the indicated doctrines (see The Bose-Einstein correlation and other tests of Chapter 6).

These unreassuring condition establish the existence of a real scientific obscurantism at the beginning of the third millennium originating from protracted complete impunity by academic interests guaranteed by lack of societal control under full support of governmental agencies funding the research. The unreassuring character is that new the conception and development of new clean fuels and energies so much needed by society basically depend on "deviations" from Einsteinian doctrines. In the final analysis, all possible energies that could be conceived with Einsteinian doctrines were fully identified half a century ago and they all turned out to be environmentally unacceptable.

Therefore, the solution of the increasing environmental problems afflicting our planet cannot be even initiated until responsible societies impose systematic ex-

perimental tests on the “limitations” of Einsteinian theories. The serious reader serious interested in knowledge, rather than in myopic personal gains, should never forget that time reversal invariant theories, such as Einsteinian doctrines, cannot credibly be assumed as being exact until the end of time for structurally irreversible processes, such as all energy releasing events.

3.10.L Original literature

Following decades of work, Santilli first proposed his Lie-admissible covering of Galilei and special relativities, today called genorelativities, in the 200 pages memoir of 1978 [43] with a full identification of the isotopic particular cases, today called isorelativity, and then continued the study in more details in two monographs of 1978 and 1982 [3, 4].

Systematic studies on isorelativity were initiated in 1983 via the following papers:

1) The first isotopies of the Lorentz symmetry on scientific record at the classical level in the paper of 1983 that includes the first known universal invariance of Riemannian line elements, Ref. [56];

2) The first isotopies of special relativity at the operator level also in 1983, Ref. [57];

3) The first known isotopies of the rotational symmetries were presented in two papers of 1985 [58, 59] that were written before the preceding two but were rejected by various journals via pseudo-reviews reported in the first paper;

4) The first isotopy of $SU(2)$ spin appeared in the papers of 1993 and 1998 [80, 107] (the second presenting intriguing application to Bell's inequality, local realism and all that);

5) A detailed study on the isotopy of the Poincaré symmetry as the universal invariance for all spacetimes with signature $(+, +, +, -)$ was published in 1993 [78];

6) The first known isotopies of the spinorial covering of the Poincaré symmetry (with momentous implications in particle physics identified in the next section) appeared in two papers of 1993 and 1995 [81, 90];

7) The unification of special and general relativity into isorelativity was systematically studied in the paper of 1998 [104].

The reading of the additional papers [64, 70–72] is instructive for the serious scientist serious on science.

The first systematic presentation of the isotopies of Galilei and Einstein's relativities with the experimental proposal to verify the isoredshift appeared in two monographs [9, 10] of 1991.

The first verification of the isodoppler shift of Santilli's isorelativity predicted in the preceding two volumes was done in 1992 by R. Mignani [158] via the numer-

ical interpretation of dramatically different redshift of quasars when physically connected to associated galaxies.

The first studies on the direct universality of Santilli's isorelativity for all possible spacetimes with signature $(+, +, +, -)$ are given by papers [115, 158, 182].

The latest study on the Lie-admissible covering of special relativity for irreversible systems was presented in the memoir [120] published by the Italian Physical Society.

Systematic studies on both the Lie-isotopic and Lie-admissible coverings of special relativity appeared in the two memoirs [12, 14] of 1995 with the update published in 2008 [22].

For various independent reviews of Santilli's iso- and geno-relativities interested scholars may consult monographs [157, 165, 179].

3.11 Hadronic Mechanics (1967)

3.11.A Foreword

Santilli's conception, construction, development, experimental verification, and industrial applications of *hadronic mechanics*, with its diversification in mathematics, physics, chemistry and biology, constitutes, without doubt, a historical scientific achievement, mostly unprecedented if one considers the novelty and variety of the needed studies by one single mind, from pure mathematics to industrial applications.

Nowadays (October 2008), hadronic mechanics constitutes a rather vast body of disciplines ranging from various coverings of Newtonian mechanics all the way to various corresponding coverings of second quantization, including as particular cases conventional classical and operator conservative formulations.

As we shall see in Chapters 4 and 5, hadronic mechanics was original conceived for: 1) Quantitative treatments of the synthesis of neutrons from protons and electrons as occurring in stars, that cannot be treated via quantum mechanics 2) Quantitative studies on the possible utilization of the inextinguishable energy contained inside the neutron; 3) The study of new clean energies and fuels that cannot even be conceived with the 20th century doctrines; and other basic advances. The implementation of these main objectives required the conception, construction and test of a sequence of branches for the treatment of matter in conditions of correspondingly increasing complexity, plus all their isoduals for antimatter.

Evidently, we can review here only the rudiments of hadronic mechanics and refer the serious scholar to a serious study of the literature made available in free pdf downloads. In particular, we shall provide the rudiments of the isotopic branch of hadronic mechanics and merely indicate the remaining geno-, hyper- and isodual branches. It should be indicated that the primary aim of

HADRONIC MECHANICS

<u>MECHANICS AND THEIR ISODUALS</u>	
Newtonian Mechanics	Isodual Newtonian Mechanics
Hamiltonian mechanics	Isodual Hamiltonian Mechanics
Quantization	Isodual Quantization
Quantum mechanics	Isodual Quantum Mechanics
Special Relativity	Isodual Special Relativity
<p>REPRESENTATION: isolated systems of point-like particles (mechanics) and antiparticles (isodual mechanics) under local, linear and potential forces.</p>	
<u>ISOMECHANICS AND THEIR ISODUALS</u>	
Iso-Newtonian Mechanics	Isodual iso-Newtonian Mech.
Iso-Hamiltonian mechanics	Isodual iso-Hamiltonian Mech.
Isoquantization	Isodual Isoquantization
Isohadronic mechanics	Isodual isohadronic Mech.
Isospecial Relativity	Isodual Special Relativity
<p>REPRESENTATION: Isolated, reversible and single-valued systems of extended particles (isomechanics) and antiparticles (isodual isomechanics) under internal, local and nonlocal, linear and nonlinear, potential and nonpotential forces.</p>	
<u>GENOMECHANICS AND THEIR ISODUALS</u>	
Geno-Newtonian Mechanics	Isodual Geno-Newtonian Mech.
Geno-Hamiltonian mechanics	Isodual Geno-Hamiltonian Mech.
Genoquantization	Isodual Genoquantization
Genohadronic mechanics	Isodual Genohadronic Mechanics
Genospecial Relativity	Isodual Genospecial Relativity
<p>REPRESENTATION: open, irreversible and single-valued systems of extended particles (genomechanics) and antiparticles (isodual genomechanics) under external, local and nonlocal, linear and nonlinear, potential and nonpotential forces.</p>	
<u>HYPERMECHANICS AND THEIR ISODUALS</u>	
Hyper-Newtonian Mechanics	Isodual Hyper-Newtonian Mech.
Hyper-Hamiltonian mechanics	Isodual Hyper-Hamiltonian Mech.
Hyperquantization	Isodual Hyperquantization
Hyperhadronic mechanics	Isodual Hyperhadronic Mech.
Hyperspecial Relativity	Isodual Hyperspecial Relativity
<p>REPRESENTATION: open, irreversible and multi-valued systems of extended particles (hypermechanics) and antiparticles (isodual hypermechanics) under external, local and nonlocal, linear and nonlinear, potential and nonpotential forces.</p>	

Figure 3.9. Classification of hadronic mechanics into its various classical and operator branches as presented by Santilli in his volumes in the field.

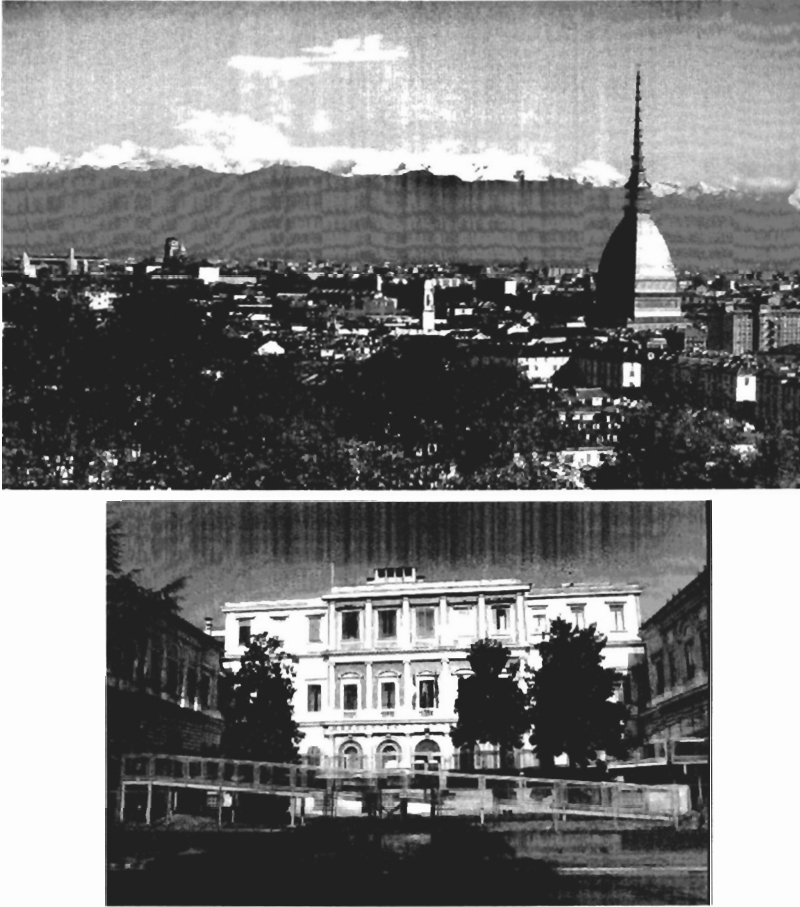

Figure 3.10. A view of the city of Torino, Italy (top view), and of the Department of Physics in Corso Massimo D'Azelio (bottom view) where Santilli conceived in 1965–1967 the foundations of hadronic mechanics.

this section is the identification of Santilli's original discoveries in the field. For all numerous subsequent contributions by various researchers around the world, interested scholars are suggested to consult the General Bibliography on Santilli Discoveries [206].

3.11.B Historical notes

The period 1965–1967

The birth of hadronic mechanics can be traced back to Santilli's Ph.D. studies in theoretical physics at the Depart of Physics of the University of Torino, Italy, with particular reference to the following papers [32–34].

On mathematical grounds, being an applied mathematician by instinct, Santilli recognized that quantum mechanics is structurally dependent on Lie theory that characterizes the infinitesimal time evolution of a (Hermitian) operator Q , $idQ/dt = [Q, H] = QH - HQ$ via the Lie product $[Q, H]$ (H being the usual Hermitian Hamiltonian representing the total energy), and the finite time evolution via the Lie transformation group $Q(t) = \exp(Hti)Q(0)\exp(-itH)$, As a pre-requisite to generalize quantum mechanics, Santilli searched for a *covering of Lie's theory*, namely, a generalization such to maintain a well defined Lie content, a mathematical feature necessary for the broader physical theory to admit quantum mechanics as a particular case.

For this purpose, Santilli proposed the first known *mutations of Lie algebras*_{*i*} (today also known as “deformations”) with product

$$(A, B) = \lambda AB - \mu BA, \tag{3.109}$$

where $\lambda, \mu, \lambda \pm \mu$ are non-null scalars. It was then simple for Santillio to discover the following generalizations of Heisenberg's time evolution in their infinitesimal and finite forms

$$idQ/dt = \lambda QH - \mu HQ = (Q, H), \tag{3.110}$$

$$Q(t) = U(t)Q(0)U^\dagger(t) = [\exp(H\mu ti)]Q(0)[\exp(-it\lambda H)], \tag{3.111}$$

with corresponding classical counterparts (see Section 3.8). Quantum mechanics and its Lie structure were then recovered identically and uniquely for the particular case $\lambda = \mu = 1$.

Because of his keen sense of scientific ethics, Santilli delayed the publication of the 1967–1968 papers for over one year to identify at least some prior literature for due quotation. In so doing, he spent months of search in mathematical libraries, not only in Italy but also in other countries, looking for some mathematical paper treating the algebra with his product (A, B) .

After such a protracted search, Santilli finally discovered a 1947 paper by the American mathematician A. A. Albert presenting the *definition without concrete examples of the notions of Lie-admissible and Jordan-admissible algebras*. An algebra U with elements a, b, c, \dots and abstract product ab was called by Albert Lie-admissible when the attached antisymmetric algebra U^- with product $[a, b] = ab - ba$ is Lie. Albert called the same algebra Jordan-admissible when the attached symmetric algebra U^+ with product $\{a, b\} = ab + ba$ is Jordan.

Santilli immediately recognized that his product (A, B) is indeed Lie- and Jordan-admissible

$$\begin{aligned} [A, B] &= (A, B) - (B, A) = (\lambda + \mu)[A, B] = \text{Lie}, \\ \{A, B\} &= (A, B) + (B, A) = (\lambda - \mu)\{A, B\} = \text{Jordan}, \end{aligned} \tag{3.112}$$

and adopted Albert's definition, particularly in view of the possibility of realizing “Jordan's dream” that his celebrated algebras would see physical applications,

although not in quantum mechanics as well known, but within the context of a covering mechanics.

Santilli then spent additional months of search in mathematics libraries to identify any papers treating Albert's Lie- and Jordan-admissible algebras. In this way, he located only two additional short notes published in rare mathematics journals treating Albert's definition although without any concrete realization.

Following such an extensive search that is rather unusual these days in the physics community, let alone for a physicist to conduct protracted searches in pure mathematical journals, Santilli released for publication his 1967–1968 papers with all pre-existing literature properly quoted, which papers present the first known realization in both mathematical and physical literature of a jointly Lie- and Jordan-admissible algebra.

On physical grounds, Santilli had understood during his Ph.D. studies that quantum mechanics is a theory structurally reversible over time and that the characterization of the conventional conservation law, such as that of the energy H , is due to the totally antisymmetric character of the Lie product for which $idH/dt = [H, H] = HH - HH = 0$.

As recalled in Section 1.1, Santilli studied Lagrange's original works and learned in this way the necessity of achieving an *irreversible generalization of quantum mechanics* as an operator counterpart of the "true Lagrange and Hamilton equations," those with external terms characterizing precisely the irreversibility of the physical world (Section 1.1).

But all known Hamiltonians (that is all 20th century interactions) are reversible over time. The representation of irreversibility then left Santilli with no other option than that of *generalizing the Lie product into a non-antisymmetric form* as a condition for an operator representation of nonconservative irreversible systems.

It is evident that Santilli Lie- and Jordan-admissible product does indeed verify the latter condition because, in general, $(A, B) - (B, A) \neq 0$. Therefore, he submitted his covering equations (3.109)–(3.112) for the *representation of open nonconservative and irreversible systems*, a central feature that is fully valid today.

The period 1978-1981

In 1967 Santilli moved to the U. S. A. for a one year research position at the University of Miami, Coral Gables, Florida, funded by NASA. During that time, he applied for a junior position in virtually all U. S. physics and mathematics departments on grounds of his studies on Lie-admissible and Jordan-admissible algebras. However, these algebras were unknown in both the mathematics and physics of the late 1960s.

He then accepted a position at the Department of Physics of Boston University partially funded by the U. S. Air Force (for which support he acquired the U. S. citizenship), and turned himself to publications that, in his words, are *typical*



Figure 3.11. A view of the Science Center of Harvard University housing (in the third floor) Harvard's Department of Mathematics where Santilli reached in 1977–1981 the main formulation of hadronic mechanics.

Phys. Rev. papers nobody quotes or cares for, some of which have been outlined in Sections 3.4, 3.5, 3.6. During that period, Santilli continued to study Lie-admissible and Jordan-admissible theories without any publication in the field for about a decade.

In 1977 Santilli joined the Lyman Laboratory of Physics of Harvard University following an invitation by the DOE for grant number DE-ACO2-80ER-10651.A00, for which Santilli was transferred at Harvard's Department of Mathematics. At that time, Santilli published two memoirs [43, 44] with the formal proposal to construct hadronic mechanics including its central dynamical equations, memoirs hereon referred to as the **1978 Original Memoirs I and II**.

The first memoir presents a detailed mathematical study of Lie-admissible and Jordan-admissible algebras with their Lie-isotopic and Jordan-isotopic particularizations, and the second memoir presents the basic equations of hadronic mechanics with first applications and illustrations.

In essence, Santilli recognized that his Lie-admissible time evolution (3.110) is *nonunitary*, $UU^\dagger \neq I$, as a necessary condition to exit from the class of unitary equivalence of quantum mechanics. Consequently, he applied a general nonunitary transformation to his parametric product (3.109), and achieved in this way the broader product today known as *Santilli general Lie- and Jordan-admissible*

product

$$(\widehat{A}, \widehat{B}) = U(A, B)U^\dagger = ARB - BSA, \quad R = UpU^\dagger, \quad S = UqU^\dagger, \quad (3.113)$$

where R , S and $R \pm S$ are now non-null operators.

Santilli also discovered that his algebra with product $(\widehat{A}, \widehat{B})$ is the most general known algebra, in the sense of admitting as particular case all infinitely possible algebras known in mathematics (characterized by a bilinear composition verifying the left and right scalar and distributive laws), including Lie algebras, Jordan algebras, flexible algebra, supersymmetric algebras, etc. Additionally, Santilli discovered that his algebras remain jointly Lie- and Jordan-admissible under all possible (nonsingular) nonunitary transforms (although the operator R and S would change).

Following the achievement of these remarkable results in the Original Memoir I, it was rather natural to propose in the Original memoir II (see, Eqs. (4.15.34), page 746) equations today known as *Santilli Lie- and Jordan-admissible dynamical equations* that are at the foundation of hadronic mechanics, here presented in the following infinitesimal and finite forms,

$$idQ/dt = QRH - HSH = (Q, H), \quad (3.114)$$

$$Q(t) = [\exp(HSti)]Q(0)[\exp(-itRH)], \quad (3.115)$$

under the condition for physical consistency (derived from time reversal) that $R = S^\dagger$.

In the same Original memoir II (see the 1978 Memoir II, Eqs. (4.15.49), page 752), Santilli identified the *fundamental Lie-isotopic equations* of hadronic mechanics as a particularization of the Lie-admissible equations, here also presented in the following infinitesimal and finite forms,

$$idQ/dt = QTH - HTH = [Q, H] \quad (3.116)$$

$$Q(t) = [\exp(HTti)]Q(0)[\exp(-itTH)], \quad (3.117)$$

under the condition of the operator T being positive definite, $T = T^\dagger > 0$.

Equations (3.114), (3.115) were proposed for the operator representation of open irreversible systems, again in view of the lack of antisymmetric character of the basic product $(\widehat{A}, \widehat{B})$, while Eqs. (3.116), (3.117) were proposed for closed-isolated systems with potential and nonpotential internal forces verifying conventional total conservation laws from the antisymmetric character of the product for which $idH/dt = HTH - HTH = 0$. It was clearly identified in the Original Proposals that the Hamiltonian represents all action-at-a-distance potential interactions, while the operators R , S and T are the operator counterparts of Lagrange's and Hamilton's external terms since they too represent contact nonpotential interactions.

In the same memoirs of 1978 Santilli proposed the Birkhoffian-admissible mechanics as classical counterpart of the Lie-admissible equations and Birkhoffian mechanics as counterpart of the Lie-isotopic particularization, although this Birkhoffian classical counterpart had to be reformulated later on due to the impossibility of achieving a consistent quantization.

Santilli's proposal of 1978 propagated quite rapidly all over the world (despite the lack of emails at that time), and received numerous authoritative supports, such as those by Nobel Laureates C. N. Yang and I. Prigogine, distinguished physicists such as S. Okubo, S. Adler, M.S. Froissart, and others, as well as known philosophers of science such as K. Popper (who praised Santilli's proposal in the preface of his last book). A feverish research was then initiated on the construction of hadronic mechanics in the necessary aspects and operational details by various mathematicians, theoreticians and experimentalists the world over, as listed in [206].

Thanks to his mathematical knowledge, Santilli initiated in 1979 the representation theory of Lie-admissible algebras. Let $|\psi\rangle$ be the module of a Lie-representation, e.g. a ket belonging to a Hilbert space with right associative action $H|\psi\rangle$. In this case the bimodular character is trivial because the action to the left is antiisomorphic to that to the right, $H|\psi\rangle = -\langle\psi|H$, $H = H^\dagger$.

For the case of Lie-admissible algebras with brackets (3.109), Santilli needed an isotopic action to the right $HS|\psi\rangle$ that is inequivalent to the to the left $\langle\psi|RH$, resulting in a new structure he called an *genobimodule* or *Lie-admissible bimodule*. These studies provided the first known Lie-admissible generalization of Schrödinger's equation and their Lie-isotopic counterpart

$$H \times^f |\psi^f\rangle = HR|\psi^f\rangle = I^f |\psi^f\rangle, \quad \langle^b\psi| \times^b H = \langle^b\psi|SH = \langle^b\psi|I, \quad (3.118)$$

$$H \widehat{\times} |\widehat{\psi}\rangle = HT|\widehat{\psi}\rangle = \widehat{I}|\widehat{\psi}\rangle, \quad \langle\widehat{\psi}| \widehat{\times} H = \langle\widehat{\psi}|TH = \langle\widehat{\psi}|\widehat{I}, \quad (3.119)$$

where, in accordance with our notations of Section 2.8, the indices f and b stand for "forward" and "backward" actions, respectively. The above realizations were subsequently studied by the physicist R. Mignani in 1981; the mathematician H. C. Myung and Santilli in 1982; Mignani, Myung and Santilli in 1983; and others (see the indicated General Bibliography).

The period 1982–1989

In 1982, Santilli left Harvard University to assume the position of President of the Institute for Basic Research, an independent institution comprising about 120 mathematicians, theoreticians and experimentalists with dual associations to other institutions around the world. To house the new Institute, the Real Estate Trust of the Santilli family purchased a Victorian house located within the compound of Harvard University, where an intense research activity was conducted until 1989 under partial financial support by the DOE.



Figure 3.12. A view of the New-England style Victorian located at 96 Prescott Street, Cambridge, MA, within the compound of Harvard University, locally known as “The Prescott House,” which was purchased by Santilli’s Real Estate Trust in summer 1981 and housed the Institute for Basic Research from September 1981 to until 1989, as well as the main editorial office of the Hadronic Journal, Hadronic Journal Supplement and Algebras, Groups and Geometries. Among the numerous research activities which took place at The Prescott House during the period 1981–1989, we mention: the initiation of systematic studies for a structural generalization of contemporary mathematics based on progressive liftings of the basic unit known as iso- and geno-mathematics and their isoduals; the conception and development of the Birkhoffian and other classical mechanics; the axiom-preserving, nonunitary, isotopic and genotopic lifting of quantum mechanics into hadronic mechanics; and numerous other fundamental mathematical and physical research (for more details, visit the IBR History webpage <http://www.i-b-r.org/ir00008.htm>).

During that period, a large number of papers, monographs and conference proceedings then followed authored by numerous scientists the world over for an estimated number of over 20,000 pages of printed research. However, with the passing of the years Santilli was more and more dissatisfied for the status of hadronic mechanics because the Lie-admissible character of the theory was indeed preserved by unitary and nonunitary transforms, but *the theory was not invariant over time*, thus predicting different numerical values under the same conditions at different times, and activating the Theorems of Catastrophic inconsistencies of Nonunitary Theories of Section 3.9.

The period 1990 to present

In 1990, the Institute for Basic Research was transferred from Cambridge MA, to Palm Harbor, FL, where it still operates to this day (Spring 2009). The main technical issue addressed during this period is that, by the early 1990s hadronic mechanics was still incomplete due to the lack of a Lie-admissible and Lie-isotopic generalization of the fundamental equation for the linear momentum and its action on a wavepacket (with $h/2\pi i = 1$),

$$p|\psi\rangle = -i\partial_r|\psi\rangle, \quad (3.120)$$

$$\psi = \exp(kr - Et), \quad p|\psi\rangle = k|\psi\rangle. \quad (3.121)$$

As Santilli recalls: *The achievement of the invariance over time of hadronic mechanics has been one of the most distressing and time consuming research problems I ever faced because I knew that quantum mathematics had to be entirely lifted into hadronic mathematics for any consistent treatment. This required the isotopic and then the genotopic liftings of all branches of quantum mechanics and all its mathematics.*

By the early 1990s "all" main aspects of quantum mathematics I was aware of had indeed been lifted, including numbers, vector and metric spaces, geometries, algebras, groups, representation theory, topology, etc. Nevertheless, the invariance of hadronic mechanics remained elusive and, most frustratingly, the lifting of the linear momentum into forms compatible with the Lie-isotopic and Lie-admissible formulations escaped continuous efforts for years by myself as well as several researchers in the field.

I remember that in early 1990s I used to control again and again all isotopic and genotopic liftings of quantum mechanics and could not identify the flaw causing lack of invariance and had no clue on how to lift the linear momentum. This was quite distressing because hadronic mechanics was not a complete theory without a consistent formulation of eigenvalue equation for the linear momentum. Above all, without such a formulation, no experimental verification could be seriously studied.

Finally, the teaching of the founders of physics came to my help. In 1994, I remembered that Newton had to build the differential calculus to formulate his mechanics. Consequently, I reinspected the differential calculus (still essentially the same since Newton's time), to see whether it was indeed applicable to hadronic mechanics and discovered that it was not because, contrary to popular beliefs in mathematics and physics for about four centuries, a conventional differential, such as that of the coordinate dr , is indeed dependent on the basic unit I of the field when the latter has a functional dependence on the local variable, $\hat{I} = \hat{I}(r, \dots) = 1/T(r, \dots)$. In fact, in this case the coordinate has to be an isocoordinate, $\hat{r} = r\hat{I}$, as a result of which $d\hat{r} \neq dr$. In this way, I formulated the isodifferential calculus for which

$$d\hat{r} = Td(r\hat{I}), \quad (3.122)$$

$$\widehat{\partial}/\widehat{\partial}\widehat{r} = \widehat{I}\partial/\partial\widehat{r}. \quad (3.123)$$

I published this discovery in 1996 at the *Rendiconti Circolo Matematico Palermo* (see Ref. [93]).

The new differential calculus finally allowed me to reach a consistent formulation of the linear momentum with isotopic and genotopic expressions fully compatible with the corresponding Lie-isotopic and Lie-admissible liftings of Heisenberg and Schrödinger equations

$$p\widehat{\times}|\widehat{\psi}\rangle = \widehat{p}T_r|\widehat{\psi}\rangle = -i\widehat{\partial}_r|\widehat{\psi}\rangle = -i\widehat{I}_r\partial_r|\widehat{\psi}\rangle, \quad \widehat{I}_r = 1/T_r = \widehat{I}_r^\dagger > 0, \quad (3.124)$$

$$\widehat{\psi} = \exp(kT_r r - ET_t t), \quad (3.125)$$

$$p\widehat{\times}|\widehat{\psi}\rangle = k|\widehat{\psi}\rangle, \quad (3.126)$$

where $\widehat{I}_r = 1/T_r$, $\widehat{I}_t = 1/T_t$ are the space and time isotopic units and elements, respectively, with corresponding expressions for the genotopic lifting. It was then easy to prove the desired invariance over time of hadronic mechanics, including the preservation of the basic unit, Hermiticity-observability, and all numerical predictions under the same conditions at subsequent time.

Following these resolutions, I separated myself from the rest of world for one entire year thanks to help from my wife Carla for food and support (without my wife's help hadronic mechanics would never have seen the light), and I wrote the second edition of "Elements of Hadronic Mechanics," Volumes I and II that I released for publication by the Ukrainian Academy of Science in 1995.

Following submission in 1995, all the background mathematics was published in 1996 by the *Rendiconti Circolo Matematico Palermo*. I reached the crucial invariance over time for the case of isomechanics in the 1997 paper [99].

I then reached the invariance over time for the much more complex Lie-admissible irreversible mechanics in the subsequent paper [100] also of 1997 that completed the formal construction of hadronic mechanics.

After that time, studies on the various applications and experimental verifications of hadronic mechanics increased exponentially thanks to the contribution by numerous colleagues. As indicated in my papers, colleagues who do not care to participate in basic new advances essentially make a gift of scientific priorities to others.

Main references of hadronic mechanics

The main references on hadronic mechanics are the following: the analytic foundations were treated in the two monographs [1, 2] of 1978 and 1982 hereon referred to as **FTP Volumes I and II**. The first comprehensive axiomatically consistent treatment of hadronic mechanics can be found in two monographs [12, 14] hereon referred to for brevity **1995 EHM Volumes I and II**. A recent Lie-admissible formulation of hadronic mechanics can be found in the memoir



Figure 3.13. A view of the The Institute for Basic Research in Florida from July 1989 to present (December 2010) that housed the achievement of maturity in the construction of hadronic mechanics, including maturity in the formulations of its mathematical, physical and chemical branches.

[120] published by the Italian Physical Society and the most recent presentation is available in the five volumes hereon referred to as **2008 HMMC Volumes I, II, III, IV, V** [20–24]. Some other papers on the subject include Refs. [117, 157, 165, 179].

3.11.C Interior and exterior dynamical systems

Physical systems were classified by Lagrange, Hamilton, Jacobi and other founders of mechanics into:

1) *Exterior dynamical systems*, consisting of a finite number of point-like particles moving in vacuum (conceived as empty space) without collisions. Note that the lack of collisions is sufficient to admit an effective point-like approximation of particles and, vice versa, the assumption of a point-like structure implies the tacit assumption of lack of collisions since dimensionless points cannot collide. Typical classical examples are given by the Solar system or a spaceship in orbit around Earth in vacuum since in both cases the actual size and shape of the constituents (the planets or the spaceship) do not affect the dynamical evolution, and said constituents can be well approximated as massive points. Typical

particle counterparts are given by the atomic structure, particles in accelerators, crystals and other systems admitting a good approximation of the constituents as being dimensionless. Note also that *all exterior systems are purely Lagrangian or Hamiltonian*, in the sense that the knowledge of only one quantity, a Lagrangian or a Hamiltonian, is sufficient to characterize the entire dynamics.

2) *Interior dynamical systems*, consisting of a finite number of constituents moving within a physical medium, in which case point-like abstraction are no longer valid, since the actual size and shape of the constituents has direct implications in the dynamical evolution. Typical classical examples are given by the structure of a planet such as Jupiter or a spaceship during re-entry in our atmosphere. Typical particle examples are given by the structure of the Sun or, along similar lines, the structure of nuclei and hadrons since, in all these cases, motion of one constituent occurs within the medium characterized by the wavepacket of other surrounding constituents. Note that *interior systems are non-Lagrangian and non-Hamiltonian*, in the sense that a given Lagrangian or Hamiltonian is insufficient to characterize the dynamics due to the need for a second quantity characterizing the contact interactions represented with external terms in the analytic equations (1.2).

As reviewed in Section 3.9, the above classification was eliminated in the 20th century by organized interests on Einsteinian doctrines via the abstraction of all particles as being point-like, consequential elimination of the contact non-Lagrangian or non-Hamiltonian interactions, and consequential elimination of interior dynamical systems.

As indicated in Section 1.1, the first and perhaps most fundamental scientific contribution by Santilli has been to prove via Theorem 1.1 that the above abstraction was a figment of academic imagination. In any case, the inconsistency of most of the 20th century particle physics can be unmasked by noting that both elastic and inelastic scattering events are impossible for dimensionless particles by conception, again, because dimensionless particles cannot influence the trajectories of other dimensionless particles except for Coulomb interactions. Alternatively, the experimental evidence of deflection of trajectories in scattering processes from a purely Coulomb behavior is evidence on the existence of non-Lagrangian and non-Hamiltonian interactions precisely according to Theorem 1.1.

It is evident that Santilli's studies, including those on hadronic mechanics, specifically refer to *interior dynamical systems* that will be the sole system considered hereon. As we shall see, the second quantity needed for the representation of size, shape and dynamics of interior systems will be given by the isounit. Hence, *special relativity and quantum mechanics are hereon assumed as being exactly valid for exterior dynamical systems, and Santilli's isorelativity and hadronic mechanics are hereon assumed as being exactly valid for interior dynamical*

systems with unique and unambiguous interconnecting limits characterized by the isounit alone.

For references in the above classification, including an accurate historical analysis, we refer the serious scholar to the 1995 FTM Volumes I and II. An instructive reading in the topic of this section is also that of Santilli's ICTP paper [67].

3.11.D *Closed and open dynamical systems*

Lagrange, Hamilton, Jacobi and other founders of mechanics introduced the following additional classification of dynamical systems:

A) *Closed dynamical systems*, given by systems that can be well approximated as being isolated from the rest of the universe, thus verifying the ten conservation laws of total quantities characterized by the Galilei or the Poincaré symmetry (the conservation of the total energy, linear momentum, angular momentum and the uniform motion of the center of mass). This is typically the case for both exterior and interior systems, whether at the classical or operator levels, when isolated from the rest of the universe.

B) *Open dynamical systems*, given by system in interaction with an external component under which at least one of the ten Galilei's or Poincaré conservation laws is not verified due to exchanges of physical quantities between the system considered and the external component. Needless to say, when the external component is included, the open system is completed into a closed form.

Again, for the intent to adapt nature to Einsteinian and quantum theories, another widespread belief of the 20th century physics has been that "closed systems can solely admit conservative-potential forces" or, equivalently, that internal, contact, nonpotential interactions do not verify all ten Galilean or Poincaré conservation laws and, consequently, the contact-nonpotential forces "do not exist in particle physics".

The above belief has caused an alteration of physical research of historical proportions because the belief is at the foundation of some of the most equivocal assumptions of the 20th century physics, such as the belief that Einstein's special relativity and quantum mechanics are exactly valid for the structure of hadrons, nuclei and stars. The political argument (political because without a serious scientific basis) is that said systems verify the ten total conservation laws when isolated from the rest of the universe. Hence, the argument says, Einsteinian doctrines and quantum mechanics hold for their interior.

Santilli has disproved this additional academic belief with his notions of:

I) *Closed non-Hamiltonian system*, or, more technically, *closed variationally nonselfadjoint systems* (see Section 2.9), given by systems verifying the ten Galilean or Poincarés conservation laws, thus being closed, yet they admit internal forces that are Hamiltonian as well as non-Hamiltonian or, more technically, variationally selfadjoint (SA) and nonselfadjoint (NSA).



Figure 3.14. A view of Santilli at the Institute for Basic Research in Florida and his two computers where he has been working from late 1989 to present weekdays standing up 8–10 hours a day for writing his main monographs, Refs. [9-25], and hundreds of papers on the final formulation of hadronic mechanics and its mathematical, physical, chemical, biological and industrial applications.

II) *Open non-Hamiltonian systems, or open variationally nonselfadjoint systems*, given by systems that do not verify at least some of the ten Galilean or Poincaré conservation laws due to non-Hamiltonian, or nonselfadjoint interactions with an external system. It is evident that these systems are *irreversible over time*.

In fact, Santilli proved in the 1982 FTM Volume II, page 235, that a Newtonian system of two or more particles with potential/selfadjoint and nonpotential/nonselfadjoint forces

$$m_k \frac{d^2 r_k}{dt^2} = F_k^{\text{SA}}(r) + F_k^{\text{NSA}}(t, r, v, a, \dots), \quad k = 1, 2, 3, \dots, \quad (3.127)$$

verifies all ten conventional total conservation laws when the nonselfadjoint forces verify the following simple algebraic conditions

$$\sum_k F_k^{\text{NSA}} = 0, \quad (3.128)$$

$$\sum_k p_k * F_k^{\text{NSA}} = 0, \quad (3.129)$$

$$\sum_k r_k \wedge F_k^{\text{NSA}} = 0, \quad (3.130)$$

where $*$ and \wedge denote scalar and vector products, respectively.

The operator counterpart of closed non-hamiltonian system is easily provided by Santilli's Lie-isotopic theory (Section 2.7), in general, and the Galilei-Santilli or Lorentz-Poincaré-Santilli isosymmetry, because: the ten conventional generators, representing the ten total conserved quantities are preserved identically by the isotopic symmetries; the selfadjoint forces are represented by the Hamiltonian; and the nonpotential forces are represented by the isounit $\tilde{I}(t, r, p, \dots) = 1/T(t, r, p, \dots)$, as we shall see. The totally symmetric character of the Lie-isotopic product $[Q, H] = QTH - HTQ$ assures total conservation laws.

Nevertheless, *closed non-Hamiltonian systems admit internal exchanges of all physical quantities, that is, we have internal exchanges not only of the energy, but also of mass, charge, angular momentum, spin, etc.* without any conflict with total conservation laws since we merely have internal exchanges that compensate each other in their sum due to the isolated character of the system. As we shall see in the next chapters, this feature alone of hadronic mechanics has far reaching implications and applications mostly beyond our imagination at this writing.

The case of open non-Hamiltonian systems is the second fundamental class of systems studied by hadronic mechanics and includes all energy releasing processes. These systems require Santilli's Lie-admissible theory (Section 2.8), since the lack of totally antisymmetric character of the brackets $(Q, H) = QRH - HSQ$ in the time evolution law (3.110) assures the description of *time rate of variations* of physical quantities of which conventional conservation laws are a particular case, in the same way as Santilli isoalgebras are a particular case of Santilli's Lie-admissible algebras.

The classical notion of closed non-Hamiltonian systems was introduced in the 1982 FTM Volume II, with the operator counterpart presented in various papers (see EHM and HMMC). An instructive reading is also that of the ICTP paper [68].

3.11.E Newton-Santilli isoequations

From Theorem 1.1, the central problem addressed by Santilli was the achievement of a mathematically and physically consistent, classical and operator formulation of non-Hamiltonian (or variationally nonselfadjoint) forces, whose correct quantization had escaped all attempts during the 20th century. Santilli knew that such an objective cannot be achieved without an action principle, since the latter is crucial for a consistent map from classical to operator forms.

But, Newtonian systems with nonpotential forces $F^{\text{NSA}}(t, r, v, \dots)$ do not admit any action principle (when formulated with conventional mathematics). Thus, Santilli searched for an identical reformulation of Newton's equation (3.127) capable of admitting a covering action principle suitable for consistent maps to operator forms. It is at this point where the dimension of Santilli's scientific edifice can be appraised, since it encompasses a variety of discoveries in various branches of mathematics, physics and chemistry, all part of one single monolithic structure that will indeed resist the test of time due to its axiomatic consistency, beauty, experimental verification and industrial applications.

Santilli struggled for decades to reformulate Newton's equations into a form admitting a covering variational principle without success, until he discovered the iso-, geno- and hyper-differential calculus in the mid 1995, that allowed him to achieve a series of structural generalization of Newton equations since Newton's "Principia" of 1687, the first known to the Foundation (evidence of dissident views is solicited for presentation in this section). The broader equations are today known as **Newton-Santilli iso-, geno-, hyper- and isodual equations**. Regrettably, we can solely indicate here the Newton-Santilli isoequations and refer the scholar to the literature available in free download.

Let $S_{\text{tot}}(t, r, p) = E(t, \times, I_t) \times E(r, \times, I_r) \times E(v, \times, I_v)$ be the Kronecker product of the representation spaces for the Newton equations with time t , coordinates r and velocity v , conventional associative multiplication $a \times b = ab$, and units $I_t = 1$, $I_r = I_p = \text{Diag.}(1, 1, 1)$. Santilli introduces the following isotopies of the Newtonian representation space with related isocoordinates, isoproducts and isounits (Section 2)

$$\widehat{S}_{\text{tot}}(\widehat{t}, \widehat{r}, \widehat{v}) = \widehat{E}(\widehat{t}, \widehat{\times}, \widehat{I}_t) \widehat{\times} \widehat{E}(\widehat{r}, \widehat{\times}, \widehat{I}_r) \widehat{\times} \widehat{E}(\widehat{v}, \widehat{\times}, \widehat{I}_v), \quad (3.131)$$

in the isotime, isocoordinates and isovelocities

$$\widehat{t} = t\widehat{I}_t, \quad \widehat{r} = r\widehat{I}_r, \quad \widehat{v} = v\widehat{I}_v \quad (3.132)$$

with real-valued, positive-definite isounits

$$\widehat{I}_t = 1/T_t = f(t, r, v, \dots), \quad \widehat{I}_r = 1/T_r = \text{Diag.}(m_1^2, m_2^2, m_3^2)g(t, \dots), \quad (3.133)$$

$$\widehat{I}_v = 1/T_v = \text{Diag.}(n_1^2, n_2^2, n_3^2)h(t, \dots).$$

Then, the **Newton-Santilli isoequations** can be written

$$\widehat{m}_k \widehat{\times} \widehat{d}\widehat{v}/\widehat{d}\widehat{t} - \widehat{F}^{\text{SA}} = 0, \quad (3.134)$$

namely, *Newton's equations with nonpotential forces on conventional spaces over conventional numbers are turned into a form with sole potential forces on iso-space over isonumbers, by embedding all nonpotential forces in the isounits, here expressed via isocoordinates and isoderivatives.*

Among the infinite number of possible solutions, we indicate the simple realization

$$\hat{I}_t = 1/T_t = 1, \quad \hat{I}_r = 1/T_r = \text{Diag.}(1, 1, 1), \tag{3.135}$$

$$\hat{I}_v = 1/T_v = \text{Diag.}(n_1^2, n_2^2, n_3^2)h(t, \dots), \tag{3.136}$$

for which Eqs. (3.134) become for the simpler one-dimensional case with $n_k = 1$, $k = 1, 2, 3$, and the simplification $\hat{m}\hat{x} = mE_mT_m = m$,

$$m\frac{d\hat{v}}{dt} - \hat{F}^{\text{SA}} = \left(m\frac{dv}{dt} - F^{\text{SA}} + mvT_v\frac{d\hat{E}_v}{dt} \right) \hat{E}_v = 0, \tag{3.137}$$

with simple solution for v constant

$$mvT_v\frac{d\hat{E}_v}{dt} = -F^{\text{NSA}}, \quad \hat{E}_v = \exp[(mv)^{-1} \int_0^t F^{\text{NSA}} dt]. \tag{3.138}$$

from which endless examples can be derived.

To understand the advance over Newton’s original conception, the serious scholar should note that the conventional Newton equations can only represent *point-like particles* due to the background local-differential topology and geometry, while the Santilli’s covering equations represent *particles with their actual extended shape under the most general possible potential and nonpotential interactions*, due to the background novel isotopology.

Additionally, Santilli has provided the **genotopic, hyperstructural and isodual coverings of Newton’s equations** for irreversible and multivalued matter systems and antimatter systems, respectively, that we cannot possibly review here.

Hence, to select the appropriate covering of Newtonian mechanics, one should identify whether the considered classical equations deal with: A) matter or antimatter; B) Closed or open systems; and C) Single-valued or multi-valued systems. Then, one should select the appropriate covering mechanics. Mathematically inclined scholars should know that Santilli has provided one single abstract formulation encompassing all possible *eight* different equations, including the conventional, iso-, geno-, hyper-systems and their isoduals, although such a unified treatment is not recommended for physical applications because excessively abstract.

Santilli’s coverings of Newton’s equations and mechanics can be studied in the 1996 RCMP memoir, and in EHM Volumes I and II.

3.11.F Hamilton-Santilli isomechanics

The embedding of the external terms in Lagrange’s and Hamilton’s equations in the generalized units, and the consequential regaining of a variationally selfadjoint

formulation on isospaces over isofields, have far reaching implications. To begin, the true Hamilton's equations (1.2) are identically rewritten in the form known as **Hamilton-Santilli isoequations**,

$$\frac{\widehat{d}\widehat{r}}{\widehat{d}\widehat{t}} = \frac{\widehat{\partial}H(\widehat{r}, \widehat{p})}{\widehat{\partial}\widehat{p}}, \quad \frac{\widehat{d}\widehat{p}}{\widehat{d}\widehat{t}} = -\frac{\widehat{\partial}H(\widehat{r}, \widehat{p})}{\widehat{\partial}\widehat{r}}, \quad (3.139)$$

namely, *the analytic equations with external terms on conventional spaces over conventional fields are identically rewritten in a form without external terms when formulated on isospaces over isofields.*

Recall that Hamilton's equations with external terms do not characterize *any* algebra with the brackets of the time evolution, let alone violate *all* Lie algebras (Section 1.1). Via Eqs. (3.139), Santilli restores an algebra in the brackets of the time evolution with external terms, and this algebra results to be a Lie isoalgebra as a covering of the algebra for the truncated analytic equations. In fact, Eqs. (3.139) characterize the time evolution of a physical quantity $Q(t)$

$$dQ/dt = [Q, H] \quad (3.140)$$

whose brackets coincide with the conventional Poisson brackets at the abstract level.

Among an infinite number of *algebraic* solutions, a simple one is given by

$$\widehat{I}_t = 1/T_t = 1, \quad \widehat{I}_r = 1/T_r = 1 - F^{\text{SA}}/F^{\text{NSA}}, \quad \widehat{I}_p = 1/T_p = 1, \quad (3.141)$$

for which

$$\frac{\widehat{d}\widehat{r}}{\widehat{d}\widehat{t}} - \frac{\widehat{\partial}H}{\widehat{\partial}\widehat{p}} = \frac{dr}{dt} - \frac{\partial H}{\partial p} = 0, \quad (3.142)$$

$$\frac{\widehat{d}\widehat{p}}{\widehat{d}\widehat{t}} + \frac{\widehat{\partial}H}{\widehat{\partial}\widehat{r}} = \frac{dp}{dt} + \frac{\partial H}{\partial r} - F^{\text{NSA}} = 0. \quad (3.143)$$

The first important consequence is that the Hamilton-Santilli isomechanics admits indeed an action principle. In fact, under the preceding simple realization Eqs. (3.139) can be derived from the *isoaction principle*

$$\widehat{\delta}\widehat{A} = \widehat{\delta} \int (\widehat{p} \widehat{\times} \widehat{d}\widehat{r} - \widehat{E} \widehat{\times} \widehat{d}\widehat{t}) = 0, \quad (3.144)$$

where one should note that the isoproduct for the space component is different than that for the time component.

The **Hamilton-Jacobi-Santilli isoequations** on isospaces over isofields expressed in terms of isocoordinates are given by

$$\widehat{\partial}_t \widehat{A} + H = 0, \quad (3.145)$$

$$\widehat{\partial}_r \widehat{A} - p = 0, \quad (3.146)$$

$$\widehat{\partial}_p \widehat{A} = 0. \quad (3.147)$$

For open irreversible single-valued or multi-valued or antimatter systems we have the **Hamilton-Santilli geno-, hyper and isodual mechanics**, respectively, we cannot review here. We can merely indicate that, in this case, at least one of the isounit must be given by a *nonsymmetric* matrix to assure the *lack* of invariance under time reversal.

Note from Section 3.11D that *the Hamilton-Santilli isomechanics is solely applicable to closed non-Hamiltonian systems*, trivially, because the antisymmetric character of the brackets of the time evolution imply the conservation of the Hamiltonian and other physical quantities.

Again, to select the appropriate covering mechanics, one should identify whether the considered system deals with: A) matter or antimatter; B) Closed or open systems; C) Single-valued or multi-valued systems. The selection of the appropriate mechanics is then consequential.

The topic of this section can be best studied in the 1996 RCMP memoir, or in EHM Volumes I and II.

3.11.G *Animalu-Santilli isoquantization*

The conventional naive quantization maps the Hamiltonian action into an expression depending on Planck's constant

$$A = \int (pdr - Hdt) \rightarrow -i(h/2\pi) \ln |\psi|, \quad (3.148)$$

thus setting the foundations for "quantized orbits" characterized by $h/2\pi$.

The map of the Hamilton-Santilli isoaction into an operator form was first identified by A. O. E. Animalu and R. M. Santilli at the XII Workshop on Hadronic Mechanics of 1990, it is today called the **Animalu-Santilli isoquantization**, and can be written

$$\widehat{A} = \int (\widehat{p} \times \widehat{d}\widehat{r} - \widehat{H} \times \widehat{d}\widehat{t}) \rightarrow -i\widehat{I}_r \widehat{\ln} |\widehat{\psi}|, \quad (3.149)$$

where one should note that \widehat{I}_r is the *coordinate* isounit. The preceding expression characterizes the lifting of Planck's constants into the space isounit

$$h/2\pi \rightarrow \widehat{I}_r(t, r, p, E, \dots), \quad (3.150)$$

under the subsidiary condition (verified naturally by all isounits used in hadronic mechanics)

$$\lim_{r \gg 1 \text{ fm}} = h/2\pi = 1. \quad (3.151)$$

Expressions (3.150), (3.151) constitute the conceptual foundations of hadronic mechanics. Recall that, by central assumption, quantum mechanics is valid for the exterior problem of point particles in vacuum, while hadronic mechanics is assumed valid for the interior problem of extended particles moving within a medium composed by other particles, as expected for the constituents of hadrons, nuclei and stars, of course, according to different degrees of mutual penetrations.

Consequently, *map (3.150) represents the fundamental assumption of hadronic mechanics according to which Planck's constant becomes a locally varying operator representing the impossibility to have quantized orbits for an extended particle immersed within a hyperdense medium as it is the case, for instance, for an electron in the core of a star, under the condition (3.151) of recovering conventionally quantized orbits when motion returns to be in vacuum.*

Hence, the serious scholar accustomed to the usually quantized orbits for the structure of atoms should not expect the same quantized orbits in the interior of hadrons, nuclei or in the core of stars to avoid evident contradictions. More specifically, when a hadronic constituent is subjected to an excited orbit, that orbit is expected to be in vacuum, rather than in the interior of hadrons, thus belonging to quantum rather than hadronic mechanics. As we shall see in Section 4, this aspect is very insidious and confuses the problem of *classification* of hadrons generally searched via a *spectrum* of *quantum* states, with the *structure* of one individual hadron for which only one orbit is possible at mutual distances smaller than the size of the wavepackets of particles.

For references and a detailed presentation, the serious scholar is suggested to study EHM Volume II and HMMC Volume III. The original contribution by Animalu and Santilli is available from the pdf file (see Ref. [63]).

3.11.H Hilbert-Santilli isospaces

The isotopic branch of hadronic mechanics is formulated on *Hilbert-Santilli isospaces* \widehat{H} that are the image of conventional Hilbert spaces H over a conventional field F under nonunitary transformations (see Section 3.11O below), with *isostates* $|\widehat{\psi}\rangle$, *isoinner product* defined on an isofield \widehat{F}

$$\langle \widehat{\psi} | \widehat{\times} | \widehat{\psi} \rangle \widehat{I} = \langle \widehat{\psi} | T | \widehat{\psi} \rangle \widehat{I} \in \widehat{F}, \quad (3.152)$$

isonormalization

$$\langle \widehat{\psi} | \widehat{\times} | \widehat{\psi} \rangle \widehat{I} = \langle \widehat{\psi} | T | \widehat{\psi} \rangle \widehat{I} = \widehat{I} \quad (3.153)$$

or

$$\langle \widehat{\psi} | T | \widehat{\psi} \rangle = 1, \quad (3.154)$$

isoexpectation values for an operator Q

$$\langle \widehat{Q} \rangle = \langle \widehat{\psi} | \widehat{\times} Q \widehat{\times} | \widehat{\psi} \rangle \widehat{I} = \langle \widehat{\psi} | T Q T | \widehat{\psi} \rangle \widehat{I}, \quad (3.155)$$

and related *theory of isolinear operators* on \widehat{H} over \widehat{F} where from now on, unless otherwise indicated, \widehat{I} and T refer to the space isounit and isotopic elements, respectively.

A fundamental property is that, if an operator Q is Hermitean on H over F , then it is *iso-Hermitean*, namely, it verifies the condition of Hermiticity on \widehat{H} over \widehat{F} ,

$$\begin{aligned} \langle \psi | (Q|\psi) \rangle I &= (\langle \psi | Q^\dagger | \psi \rangle) I \rightarrow \\ \langle \widehat{\psi} | T(QT|\widehat{\psi}) \widehat{I} &= (\langle \widehat{\psi} | TQ^\dagger | \widehat{\psi} \rangle) \widehat{I}. \end{aligned} \tag{3.156}$$

Consequently, *any physical quantity that is observable for quantum mechanics is equally observable for the covering hadronic mechanics.*

Note that \widehat{I} is indeed the correct right and left unit of the isotopic branch of hadronic mechanics because it verifies the identities

$$\widehat{I} \widehat{\times} |\widehat{\psi}\rangle = \widehat{I} T |\widehat{\psi}\rangle = |\widehat{\psi}\rangle, \quad \langle \widehat{\psi} | \widehat{\times} \widehat{I} = \langle \widehat{\psi} | \widehat{I} I = \langle \widehat{\psi} | \tag{3.157}$$

with isoexpectation value

$$\langle \widehat{I} \rangle = \langle \widehat{\psi} | T \widehat{I} T |\widehat{\psi}\rangle \widehat{I} = \langle \widehat{\psi} | T |\widehat{\psi}\rangle \widehat{I} = \widehat{I}. \tag{3.158}$$

For details, extension to geno-, hyper- and isodual cases, and historical notes we refer the interested scholar to the 1995 EHM Volumes I and II.

3.11.1 Schrödinger-Santilli isoequations

As indicated earlier, the first lifting of Schrödinger's equations was done by Santilli in 1979, and reinspected in various works. The final version was reached by Santilli in the 1996 RCMP memoir as part of the discovery of the differential calculus. The desired equations can be expressed via the image of the Hamilton-Jacobi-Santilli isoequations (3.145)–(3.147) under map (3.149). For the simple case of a constant isounit, or an isounit averaged to constant, the isoequation can be written

$$\widehat{\partial}_t \widehat{A} + H = 0 \rightarrow -i(h/2\pi) \widehat{I}_r \widehat{\partial}_t (\widehat{\text{Ln}}|\widehat{\psi}\rangle) + H = 0, \tag{3.159}$$

$$\widehat{\partial}_r \widehat{A} - p = 0 \rightarrow -i(h/2\pi) \widehat{I}_r \widehat{\partial}_r (\widehat{\text{Ln}}|\widehat{\psi}\rangle) - p = 0, \tag{3.160}$$

$$\widehat{\partial}_p \widehat{A} = 0 \rightarrow -i(h/2\pi) \widehat{I} \widehat{\partial}_p (\widehat{\text{Ln}}|\widehat{\psi}\rangle) = 0, \tag{3.161}$$

where all coordinates and their derivatives are isotopic.

Via elementary calculations, the above equations can be written in the final form known as **Schrödinger-Santilli isoequations**

$$-i \widehat{\partial}_t |\widehat{\psi}\rangle = -i \widehat{I}_t \widehat{\partial}_t |\widehat{\psi}\rangle = H \widehat{\times} |\widehat{\psi}\rangle = H T_r |\widehat{\psi}\rangle = E |\widehat{\psi}\rangle, \tag{3.162}$$

$$p \widehat{\times} |\widehat{\psi}\rangle = p T_r |\widehat{\psi}\rangle = -i \widehat{\partial}_r |\widehat{\psi}\rangle = -i \widehat{I}_r \widehat{\partial}_r |\widehat{\psi}\rangle, \tag{3.163}$$

$$-i\widehat{I}\widehat{\partial}_p|\widehat{\psi}\rangle = 0, \quad (3.164)$$

where one should note the *natural emergence of the isodifferential calculus*; as well as the last condition expressing the independence of the isowavefunction from the momenta, which condition is crucial for hadronic mechanics to be an axiom-preserving covering of quantum mechanics.

The study of open irreversible single or multi valued matter systems and their antimatter counterparts requires the use of **Schrödinger-Santilli geno-, hyper- and isodual equations**, respectively, we cannot possibly review here.

Serious scholars are suggested to study EHM Volumes I and II and HMMC Volume III.

3.11.J Heisenberg-Santilli isoequations

The isotopies of Heisenberg's equations were discovered by Santilli in the 1978 original memoirs, their final version was also reached in the 1996 RCMP memoir jointly with the discovery of the isodifferential calculus, are today called **Heisenberg-Santilli isoequations**, and can be written for the time evolution of an iso-Hermitian operator $Q(t)$ in the finite form (with simplifications of inessential isoproducts and the simple assumption $\widehat{I}_t = 1$)

$$Q(t) = W(t)Q(0)W^\dagger(t) = \exp(HTti)Q(0)\exp(-itTH), \quad (3.165)$$

with infinitesimal form easily derivable from the preceding expression (where we ignore again for simplicity the isotopy of time)

$$idQ/dt = QTH - HTQ = [Q, H]. \quad (3.166)$$

and **canonical isocommutation rules** also reached for the first time in the 1996 RCMP memoir

$$[\widehat{r}, \widehat{p}] = i\widehat{I}_r, \quad [\widehat{r}, r] = [\widehat{p}, p] = 0. \quad (3.167)$$

For details, we suggest study EHM Volumes I and II and HMMC Volume III.

3.11.K Dirac-Myung-Santilli isodelta function and elimination of quantum divergencies

One of the main limitations of quantum mechanics has been the emergence of divergencies, such as the divergent character of the perturbation theory for strong interactions, divergencies in Feynman's diagrams, and others. One of the main contributions of hadronic mechanics is the elimination of quantum divergencies *ab initio*, thus permitting, for the first time in scientific history, *convergent perturbative expansions for strong interactions*.

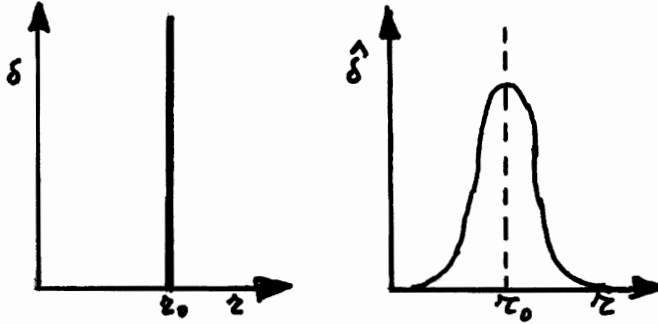

Figure 3.15. An illustration (left) of the origin of the divergencies of quantum mechanics in the singularity of Dirac’s delta function $\delta(r - r_0)$ at the value $r = r_0$, and their removal *ab initio* in hadronic mechanics (right) by the Dirac-Myung-Santilli isodelta function that no longer admits the preceding divergencies for a suitable selection of the isotopic element, here considered as being dependent on $(r - r_0)^2$. In fact, the removal of the divergencies at the indicated level carries over at all levels the scattering and perturbation theories of hadronic mechanics.

As it is well known, the origin of the divergencies in quantum mechanics rests with the point-like abstraction of particles, which abstraction is technically represented by the Dirac delta function $\delta(r - r_0)$ that is divergent at $r = r_0$. However, the image of the Dirac delta function in hadronic mechanics, today known as **Dirac-Myung-Santilli isodelta function** from a paper of said originators of 1982, is given by

$$\widehat{\delta}(r - r_0) = \int_{-\infty}^{+\infty} e^{ikT(r-r_0)} dk, \tag{3.168}$$

where, as one can see, **there is no longer a singularity at $r = r_0$** under a suitable selection of the isotopic element. In turn, it is evident that the scattering theories of hadronic mechanics are free of divergencies from their very foundations, as shown in existing papers.

Additionally, for any given divergent or weakly convergent series

$$Q(w) = I + w(QH - HQ)/1! + \dots \rightarrow \infty, \quad I = 1$$

there always exists an isounit $\widehat{I} = 1/T$ whose value (or average value) is much bigger than w (the isotopic element is much smaller than w) under which the above series becomes strongly convergent, namely, it verifies the expression where N is a finite positive number

$$Q(w) = \widehat{I} + w(QTH - HTQ)/1! + \dots \leq N. \tag{3.169}$$

The isodelta function was presented for the first time in [52]. The name of *Dirac-Myung-Santilli delta function* was introduced by M. Nishioka in the paper [150] of 1984. See also paper [151] by the same author.

The above pioneering studies established the absence of quantum divergencies in hadronic mechanics and were followed by several studies reviewed in EHM Vol. II, including the convergence of isoperturbation expansions. The most recent contribution in the new scattering theory of hadronic mechanics (that will be reviewed in Chapter 5) is that by an international collaboration headed by Santilli and Animalu currently (December 2008) under finalization (Ref. [126]).

3.11.L Genotopic and hyperstructural branches of hadronic mechanics

The starting point for the geno- and hyper-coverings of isomechanics is, again, Newton's equation, this time for the embedding of irreversibility in the mathematical foundations of the dynamics, via the genotopic lifting of the basic unit of the Euclidean space and related associative product among two generic quantities G_k , $k = 1, 2$, into two inequivalent formulations, one to the right and a complementary one to the left (see Section 2.8), where, again, the symbols f and b denote forward and backward dynamics, respectively,

$$I^f = 1/S, \quad G_i \times^f G_j = G_i \times S \times G_j, \quad (3.170)$$

$${}^b I = 1/R, \quad {}_i G^b \times_j G = {}_i G \times S \times_j G, \quad (3.171)$$

with interconnection crucial for consistent time reversal images

$$I^f = 1/S = ({}^b I)^\dagger, \quad (3.172)$$

in which case the right and left genounits are indeed the correct units for both products.

The next step is the selection of one direction in time, generally assumed to be the forward, and represent it with Santilli genomathematics to the right, that is, with genonumbers to the right, genospaces to the right, genogeometries to the right, etc. To avoid catastrophic inconsistencies often not noted by non-experts in the field, the above selection requires the religious restriction of *all* multiplication and other operations to the right.

Under the above foundations, we have the **Newton-Santilli genoequations to the right**

$$m_k^f \times^f d^f v^f / d^f t^f - F^{fSA} = 0 \quad (3.173)$$

that, as one can see, is indeed irreversible because it is inequivalent to its time reversal image. Similarly, we have the **Hamilton-Santilli genoequations to the right**

$$d^f r^f / d^f t^f = \partial^f H(r^f, p^f) / \partial^f p^f, \quad d^f p^f / d^f t^f = -\partial^f H(r^f, p^f) / \partial^f r^f, \quad (3.174)$$

related **genoaction to the right** and **Hamilton-Jacobi-Santilli genoequations to the right** here omitted for brevity; the **Schrödinger-Santilli genoequations to the right**

$$-i\partial_t^f |\psi^f\rangle = -iI_t^f \partial_t |\psi^f\rangle = H \times^f |\psi^f\rangle = HS|\widehat{\psi}\rangle = E|\psi^f\rangle, \quad (3.175)$$

$$p \times^f |\psi^f\rangle = pS|\psi^f\rangle = -i\partial_r^f |\psi^f\rangle = -iI^f \partial_r |\psi^f\rangle, \quad (3.176)$$

action on a geno-Hilbert space to the right, and the **Heisenberg-Santilli geno-equations** evidently including both actions to the right and to the left because originating from corresponding universal enveloping genoassociative algebras (see Section 2.8)

$$Q(t) = W(t)Q(0)Z^\dagger(t) = \exp(HSti)Q(0)\exp(-itRH), \quad (3.177)$$

$$idQ/dt = QRH - HSQ = (Q, H), \quad (3.178)$$

with corresponding genotopies of all remaining aspects of the isotopic branch of hadronic mechanics.

The **hyperstructural branch to the right** (primarily used for biological structures but also for multi-dimensional universes in physics) is essentially given by the above genotopic branch in which the genounits are assumed to be multi-valued, that is, to have a finite ordered set of values

$$I^r = 1/S = \{I^{1r}, I^{2r}, I^{3r}, \dots\}, \quad (3.179)$$

$${}^l I = 1/R = \{\dots, {}^3 I, {}^2 I, {}^1 I\}, \quad (3.180)$$

with all multi-valued hyperstructures following from the above basic assumption on the fundamental unit.

A serious study of the above geno- and hyper-mechanics can only be achieved with a serious study of Santilli's 1996 RCMP memoir, the 1995 EHM Volumes I and II and the 2008 HMMC Volume III.

3.11.M *Isodual branches of hadronic mechanics*

Hadronic mechanics admits four different isodual branches for the representation of antimatter in conditions of increasing complexity according to the following classification:

1) **isodual quantum mechanics**, for the description of point-like abstractions of antiparticles in exterior dynamical conditions in vacuum (presented in Section 3.10);

2) **Isodual isomechanics**, for the description of closed non-Hamiltonian systems of extended antiparticles;

3) **Isodual genomechanics**, for the description of open systems of extended antiparticles; and

4) **Isodual hypermechanics**, for the description of multi-valued universes of antimatter.

All the above isodual mechanics can be constructed from the corresponding mechanics for matter via the application of the **isodual map**

$$Q(t, r, p, \dots) \rightarrow -Q^\dagger(-t^\dagger, -r^\dagger, -p^\dagger, \dots), \quad (3.181)$$

to the *totality* of the quantities for matter and the *totality* of their operations.

For a serious knowledge we suggest again the study of Santilli's 1996 RCMP memoir, the 1995 EHM Volumes I and II and the 2008 HMMC Volume III.

3.11.N Two-body hadronic system

A typical two-body quantum mechanical system is given by the hydrogen atom in which the two constituents are well approximated as being point-like since the mutual distance is much bigger than the size of the wavepacket of the constituents. In this case, the system is entirely represented with a Hamiltonian of the type

$$H(r, p) = \sum_k p_k^2/2m_k + V(r). \quad (3.182)$$

In the corresponding case of two body hadronic systems, the constituents are at mutual distances equal or smaller than 1 fm = 10^{-13} cm, in which case the preceding point-like abstraction of the constituents is no longer valid because the actual extended character of the constituents, their actual shape, their density and other features, directly affect the dynamics.

Suppose that the two particles have the shape of spheroid ellipsoids with semi-axes n_{ak}^2 , $a = 1, 2$, $k = 1, 2, 3$. Clearly, the representation of these shapes is beyond any capability of a Hamiltonian, but shapes can be easily represented via Santilli's isounit.

Suppose that the above two extended particles with wavefunctions ψ_1 and ψ_2 are in conditions of partial mutual penetration (Figure 1.3), as it is the case for electrons in valence bonds, hadronic constituents, nuclear constituents and other structures. These physical conditions evidently cause nonlocal interactions extended over the volume of mutual overlapping that can be represented with volume integral $\int \psi_1^\dagger(r)\psi_2(r)dr^3$.

Clearly, this mutual penetration cannot be represented with a quantum Hamiltonian for numerous reasons, beginning with a granting of potential energy to contact nonpotential effects, let alone the violation of the background local-differential topology. However, the same interactions can be readily represented with Santilli's isounit because the underlying topology is indeed nonlocal-integral.

By combining these and other aspects, we can see that the considered two-body hadronic system can be characterized by the Schrödinger-Santilli isoequation (3.162), or the Heisenberg-Santilli isoequation (3.166), with the same Hamiltonian H as in Eq. (3.182), plus the isotopic element T given by

$$T = \text{Diag.}(1/n_{11}^2, 1/n_{12}^2, 1/n_{13}^2)\text{Diag.}(1/n_{21}^2, 1/n_{22}^2, 1/n_{23}^2) \times \exp[-F(t, r, p, E, \mu, \psi\hat{\psi}, \dots) \int \psi_1^\dagger(r)\psi_2(r)dr^3], \quad (3.183)$$

where the exponent in general and the F function in particular, originate at the Newtonian level as in Eq. (3.138) and represent nonpotential interactions whose explicit form depends on the case at hand (see the applications in Chapters 4 and 5). Note that isotopic element (3.183) verifies the condition for strong isoconvergence of divergent quantum series, Eq. (3.169).

A most important feature of the above isotopic element is that, for mutual distances much bigger than 1 fm, the volume integral is null and the shapes become spherical due to absence of nonlocal interactions, thus verifying the basic condition (3.151), i.e.,

$$\lim_{r \gg 1 \text{ fm}} T = I, \quad (3.184)$$

namely, *hadronic mechanics recovers quantum mechanics uniquely and identically for all mutual distances of particles bigger than their size.*

As a result, *hadronic mechanics has been built to provide a “completion” of quantum mechanics solely applicable at short distances essentially along the historical argument by Einstein, Podolsky and Rosen (see below for more comments). As we shall see in the next chapters, two body hadronic bound states with Hamiltonian (3.182) and isotopic element (3.183), when applicable, provide exact numerical representations in various fields that are impossible with quantum mechanics.*

3.11.0 Simple construction of hadronic mechanics

It is important for readers to know that all mathematical and physical methods of hadronic mechanics can be constructed via the simple nonunitary transform of quantum models. This construction was first identified by Santilli in the 1978 original memoirs, studied extensively by various authors and will be heavily used in the subsequent outline of experimental verifications and applications of hadronic mechanics.

Construction of isomodels. The starting point is the identification of the nonunitary transform with the basic isounit of the model. For the case of two-body hadronic particles, the isounit is the inverse of the isotopic element (3.183), therefore yielding the identification

$$WW^\dagger = \hat{I} = \text{Diag.}(n_{11}^2, n_{12}^2, n_{13}^2) \text{Diag.}(n_{21}^2, n_{22}^2, n_{23}^2) \times \\ \exp[F(t, r, p, E, \mu, \psi\hat{\psi}, \dots)] \int \psi_1^\dagger \psi_2 dr^3. \quad (3.185)$$

Once Santilli's isounit has been identified on groups of physical requirements (see the Chapters 4 and 5 for numerous realizations), the lifting of a quantum model into the hadronic form is simply achieved via the application of the above nonunitary transform to the *totality* of the mathematics and physics of the considered quantum model, without exceptions to avoid catastrophic inconsistencies.

In this way, we have the very simple lifting of the unit I of quantum mechanics into the isounit,

$$I \rightarrow WIW^\dagger = \hat{I}, \quad (3.186)$$

the lifting of numbers n into isonumbers

$$n \rightarrow UnU^\dagger = \hat{n} = n\hat{I}, \quad (3.187)$$

the lifting of conventional associative product nm between two numbers n and m into the isoproduct

$$nm \rightarrow U(nm)U^\dagger = (UnU^\dagger)(UU^\dagger)^{-1}(UmU^\dagger) = \hat{n}T\hat{m} = \hat{n}\hat{\times}\hat{m}, \quad (3.188)$$

the lifting of Hilbert states $|\psi\rangle$ into Hilbert-Santilli isostates $|\hat{\psi}\rangle$

$$|\psi\rangle \rightarrow U|\psi\rangle U^\dagger = |\hat{\psi}\rangle, \quad (3.189)$$

the lifting of the conventional Hilbert product into the *inner isoproduct* over the isofield of isocomplex isonumbers

$$\langle\psi|\psi\rangle \rightarrow U\langle\psi|\psi\rangle U^\dagger = \langle\hat{\psi}|T|\hat{\psi}\rangle\hat{I}, \quad (3.190)$$

the lifting of the conventional Schrödinger equation into the Schrödinger-Santilli isoequation

$$H|\psi\rangle = E|\psi\rangle \rightarrow U[H|\psi\rangle]U^\dagger = (UHU^\dagger)(UU^\dagger)^{-1}(U|\psi\rangle U^\dagger) = \hat{H}T|\hat{\psi}\rangle = \hat{H}\hat{\times}|\hat{\psi}\rangle = U(E|\hat{\psi}\rangle)U^\dagger = E'|\hat{\psi}\rangle, \quad (3.191)$$

where one should note the *change in the numerical value of the eigenvalue*, $E \rightarrow E'$ called *isorenormalization*. In fact, E is the eigenvalue of H , while E' is the eigenvalue of the different operator HT , thus implying that $E \neq E'$. Clearly, *the isorenormalization of the energy is a fundamental feature of hadronic mechanics for numerous applications*.

Construction of geno- and hyper-models. Genomodels are constructed via *two* different nonunitary transforms,

$$WW^\dagger \neq I, \quad ZZ^\dagger \neq I, \quad (3.192)$$

and the following identification of the forward and backward genounit

$$I^f = WZ^\dagger, \quad {}^bI = ZW^\dagger. \quad (3.193)$$

The entire forward and backward genotopic branch of hadronic mechanics can then be constructed by applying the above nonunitary transforms to the totality of the quantum formalism. A similar procedure holds for the construction of the forward and backward hyperstructural branches of hadronic mechanics.

3.11.P *Invariance of hadronic mechanics*

As indicated earlier, the physical consistency of quantum mechanics is due to the invariance over time of: the basic units of measurements, the observability of operators and the preservation of the same numerical predictions under the same conditions at different times. Hadronic mechanics does indeed verify these central conditions of physical consistency, although at a covering level.

This feature can be simply seen as follows. Recall that the time evolution of hadronic mechanics is nonunitary when defined on a conventional Hilbert space defined over a conventional field of complex numbers. It is easy to see that, under these assumptions, hadronic mechanics is *not* invariant over time. In fact, following the identification of the isounit with a nonunitary transform, Eq. (3.186), a repeated application of the same transform does not leave invariant the isounit,

$$\widehat{I} \rightarrow W\widehat{I}W^\dagger = \widehat{I}' \neq \widehat{I}. \tag{3.194}$$

But, as stressed before, hadronic mechanics must be elaborated with its own mathematics to prevent inconsistencies. Hence, nonunitary transforms must be reformulated in the following *isounitary transformations*

$$WW^\dagger \neq I, \quad W = \widehat{W}T^{1/2}, \tag{3.195}$$

$$WW^\dagger = \widehat{W} \widehat{\times} \widehat{W}^\dagger = \widehat{W}^\dagger \widehat{W} = \widehat{I}, \tag{3.196}$$

It is then easy to see that *isounitary transformations preserve Santilli's isounit, thus preserving over time the basic units of measurements and the actual shape of particles,*

$$\widehat{I} \rightarrow \widehat{W} \widehat{\times} \widehat{I} \widehat{\times} \widehat{W}^\dagger = \widehat{I}. \tag{3.197}$$

It is also easy to prove that *isounitary transforms preserve Hermiticity, thus preserving the observability of operators,*

$$\widehat{H} = \widehat{H}^\dagger \rightarrow \widehat{W} \times \widehat{H} \times \widehat{W}^\dagger = \widehat{H}' = (\widehat{H}')^\dagger. \tag{3.198}$$

Finally, it is easy to see that *isounitary transforms predict the same numerical values under the same conditions at different times* because of the verification of the following condition at the isounitary level

$$\begin{aligned} \widehat{H}T|\widehat{\psi}\rangle = E|\widehat{\psi}\rangle \rightarrow \widehat{W} \widehat{\times} (\widehat{H} \widehat{\times} |\widehat{\psi}\rangle) \widehat{\times} \widehat{W}^\dagger = \widehat{H}' \widehat{\times} |\widehat{\psi}'\rangle = \\ \widehat{W} \widehat{\times} (E|\widehat{\psi}\rangle) \widehat{\times} \widehat{W}^\dagger = E|\widehat{\psi}'\rangle \end{aligned} \tag{3.199}$$

in which one should note the *invariance of the numerical value of the isotopic operator and of the isoeigenvalue.*

The invariance of Lie-admissible branch of hadronic mechanics, when formulated on Hilbert-Santilli genospaces over genofields, follows the same lines. This invariance was first studied in the 1997 paper [100].

3.11.Q *Relativistic hadronic mechanics*

Foreword

Relativistic hadronic mechanics is, of course, the most important branch of the new discipline for experimental verifications (Chapter 5), theoretical predictions (Chapter 6) and industrial applications (Chapter 7). It comprises the isotopic, genotopic and hyperstructural liftings of conventional relativistic quantum mechanics for matter in non-Hamiltonian reversible, irreversible and multi-valued conditions, respectively, and their isoduals for antimatter in corresponding conditions.

Evidently, we cannot possibly review such a vast structure and are regrettably forced to provide the main lines solely for the isotopic branch, hereon referred to as *isorelativistic hadronic mechanics*. Paper [99] presents relativistic isomechanics in a final invariant form. The most comprehensive presentation of the field remains Santilli's 1995 monograph [14].

The primary scope of isorelativistic hadronic mechanics is to provide a quantitative representation of the *mutations of "particles" into "isoparticles," namely, the alteration of the "intrinsic" as well as kinematic characteristics of particles in the transition from motion in empty space to motion within a hadronic medium*, while recovering relativistic quantum mechanics uniquely and identically when the particles return to move in vacuum or, equivalently, when particles are at sufficient mutual distances to allow their point-like abstraction.

Recall that particles can be defined as unitary irreducible representations of the Lorentz-Poincaré symmetry, while isoparticles can be defined as isounitary irreducible representations of the covering Lorentz-Poincaré-Santilli isosymmetry studied in Section 3.10 for the conventional case and in this section for the covering isospinorial form.

The mutation (also called isonormalization) of the rest energy of particles is an unavoidable consequence of all nontrivial isotopies of the Lorentz-Poincaré symmetry. However, the mutation of spin, charge and other intrinsic characteristics depends on the energy or, equivalently, the density of the hadronic medium considered.

This setting led Santilli to identify two main cases, the first in which isoparticles maintain the conventional values of spin, charge and other characteristics, and the second in which these characteristic too are mutated.

We can now clarify the *title* of the memoir [44] proposing the construction of hadronic mechanics. In essence, a particle with spin $1/2$ preserves its spin under *external electromagnetic interactions*, as well known, in which case Pauli's principle is evidently verified. However, Santilli argued that *particles may experience a mutation of their spin under external strong interactions*, such as for nucleons passing very near nuclei considered as fixed and external, in which case an exper-

imental verification of Pauli's principle and, consequently of special relativity, is necessary.

The aspect that does not appear to have sufficiently propagated in the physics community, thus leading to misinterpretation or vacuous judgments, is that *spin mutations are "internal" effects within hadronic matter that, as such, are not visible from the outside*. Alternatively, Santilli argues that if a hadron has the conventional spin 1/2, this does not necessarily imply that its constituents have conventional spin because there could be internal mutations such to compensate each other resulting in the total spin 1/2, in a way similar to the mutual compensation of internal nonconservative forces resulting in total conservation laws (Section 3.11D). Hence, the "external" character of strong interactions is crucial to avoid vacuous claims of "experimental verification" of Pauli's exclusion principle.

Some 30 years following Santilli's call in 1978 to test Pauli's principle, a number of meetings have been recently organized in the subject (without consulting Santilli or quoting his 1978 origination). We assume the serious scholar is aware of the fact that any deviations from Pauli's principle is impossible when data are elaborated via quantum mechanics, since no spin mutation is the possible. Similarly, the serious scholar is assumed to know that hadronic mechanics is the only known axiomatically consistent mechanics predicting deviations from Pauli's principle under the indicated external strong interactions (the verification of Pauli's principle in heavy atoms causing deep wave overlappings of the wavepackets of peripheral electrons with consequential nonlocal nonunitary and nonquantum effects, can be done in a similar way by considering one peripheral electron while the rest of the system is assumed as external).

Isolinearization of second order isoinvariants

Nonrelativistic hadronic mechanics outlined in the preceding sections is characterized by the Galilei-Santilli isosymmetry not presented in these lines for brevity, but treated in detail in monographs [9, 10].

Isorelativistic hadronic mechanics is then characterized by the Lorentz-Poincaré-Santilli isosymmetry of Section 3.10 defined on an iso-Minkowskian space $\widehat{M}(\widehat{r}, \widehat{m}, \widehat{R})$ under the interpretation of the generators as Hermitian operators on a Hilbert-Santilli isospace over the isofield \widehat{R} with isounit $\widehat{I} = 1/T > 0$ and realization of the 4-dimensional isolinear (meaning linear on isospaces over isofields) momentum operator

$$\widehat{p}_k \widehat{\times} |\widehat{e}\rangle = \widehat{p}_k T |\widehat{e}\rangle = -i \widehat{\partial}_k |\widehat{e}\rangle = -i \widehat{T}_k^j \partial_j |\widehat{e}\rangle, \quad k = 1, 2, 3, 4, \quad (3.200)$$

with isostates $|\widehat{e}\rangle$ of a Hilbert-Santilli isospace, the symbol "e" indicating the electron as the primary represented quantity, and the asterisk indicating mutation into the isoelectron.

The second order Casimir-Santilli isoinvariant (3.81) then yields the following **Klein-Gordon-Santilli isorelativistic equation** here written in its projection in our spacetime for simplicity

$$\widehat{m}^{ij}\widehat{p}_i T\widehat{p}_j T|\widehat{e}\rangle = m'^2 C^2 |\widehat{e}\rangle \quad (3.201)$$

or equivalently

$$(\widehat{m}^{ij}\widehat{\partial}_i\widehat{\partial}_j - m'^2 C^2)|\widehat{e}\rangle = 0, \quad (3.202)$$

where: the isometric (namely a matrix with isonumbers as elements) has been simplified to the form $\widehat{M} = \widehat{m}\widehat{I}$, thus avoiding the isomultiplication in the left hand side because $\widehat{M}T\widehat{p}\dots = \widehat{m}\widehat{p}\dots$; m' is the isorenormalized mass, $C = c/n_4$ is the local speed of light and the isoproduct in the r.h.d. has been removed because trivial.

The ‘‘isolinearization’’ of the above second order isoequation has been studied extensively by Santilli, (see EHM Volume II) resulting in the **Dirac-Santilli isoequation** that we write in the simplified form also projected in our spacetime

$$(i\widehat{\gamma}^k\widehat{\partial}_k - m'C)|\widehat{e}\rangle = 0, \quad (3.203)$$

where $\widehat{\partial}_k$ are the isoderivatives, and $\widehat{\gamma}^k$ are the **Dirac-Santilli isomatrices** with antiisocommutation rules

$$\{\widehat{\gamma}^i, \widehat{\gamma}^j\} = \widehat{\gamma}^i T\widehat{\gamma}^j + \widehat{\gamma}^j T\widehat{\gamma}^i = \widehat{m}^{ij} \quad (3.204)$$

showing the appearance of the fundamental isometric directly in the structure of the isoequation. We assume the reader has acquired at least a minimal knowledge of preceding sections to understand that *the Dirac-Santilli isoequation introduces, for the first time Riemannian, Finslerian and other gravitational effects directly in the dynamics of the electron under interior conditions.*

Pauli-Santilli isomatrices

To identify the structure of the Dirac-Santilli isoequation, we must first review the isotopies of $SU(2)$ -spin with particular reference to the isotopies of its fundamental representation via Pauli’s matrices, first studies by Santilli in various works, such as Refs. [80, 107], and reviewed extensively in EHM-II Chapter 6. As indicated above, we have to distinguish the following two cases:

CASE I: Pauli-Santilli isomatrices without spin mutation

This case is characterized by the so-called *regular isounitary isorepresentations* of the Lie-Santilli isosymmetry $\widehat{SU}(2)$. This case can be easily constructed via a nonunitary transformation of the conventional Pauli matrices.

Let σ_k , $k = 1, 2, 3$, be the conventional Pauli matrices defined on a two-dimensional, complex valued, Euclidean space $E(r, \delta, R)$ with trivial metric $\delta =$

Diag.(1, 1, 1). Consider the Euclid-Santilli isospace $\widehat{e}(\widehat{r}, \widehat{\delta}, \widehat{R})$ on a Hilbert-Santilli isospace with isostates $|\widehat{s}\rangle$ and isometric

$$\widehat{\delta} = \text{Diag.}(1/s_1^2, 1/s_2^2), \tag{3.205}$$

where s_1 and s_2 are non-null numbers. Assume for Santilli isounit the nonunitary transform

$$\widehat{I} = 1/T = U_{2 \times 2} U_{2 \times 2}^\dagger = \text{Diag.}(s_1^2, s_2^2). \tag{3.206}$$

Then, the *regular Pauli-Santilli isomatrices* are given by

$$\widehat{\sigma}_k = U_{2 \times 2} \sigma_k U_{2 \times 2}^\dagger, \quad k = 1, 2, 3, \tag{3.207}$$

$$\widehat{\sigma}_1 = \text{Diag.}(s_1^2, s_2^2), \quad \widehat{\sigma}_2 = \text{Diag.}(-is_1^2, is_2^2), \quad \widehat{\sigma}_3 = \text{Diag.}(s_1^2, s_2^2), \tag{3.208}$$

and verify the following isocommutation relations and isoeigenvalues expressions

$$[\widehat{\sigma}_i, \widehat{\sigma}_j] = \widehat{\sigma}_i T \widehat{\sigma}_j - \widehat{\sigma}_j T \widehat{\sigma}_i = i2\varepsilon_{ijk} \widehat{\sigma}_k, \tag{3.209}$$

$$\widehat{\sigma}^2 T |\widehat{s}\rangle = \sum_k \widehat{\sigma}_k T \widehat{\sigma}_k T |\widehat{s}\rangle = 3|\widehat{s}\rangle, \tag{3.210}$$

$$\widehat{\sigma}_3 T |\widehat{s}\rangle = \pm |\widehat{s}\rangle. \tag{3.211}$$

The preservation of the conventional eigenvalues for spin 1/2 is evident, a feature that Santilli proved to extend to all spins (see EHM-II).

Prior to venturing vacuous judgments of triviality, serious readers should be aware that the above Pauli-Santilli isomatrices provide an explicit and concrete realization of hidden variables for

$$\lambda = s_1^2 = s_2^{-2} \tag{3.212}$$

by consequently voiding Bell's inequality of final character, since no longer valid under Santilli isotopies. For technical details, one should study the seminal paper [107].

CASE II: Pauli-Santilli isomatrices with spin mutation

This case is characterized by the *irregular isorepresentations* of the Lie-Santilli $\widehat{SU}(2)$. The latter cannot any longer be derived via a trivial nonunitary transform of the Lie case and constitute an intrinsic new feature of the Lie-Santilli isothory without any correspondence with the conventional theory, although the latter always remains a particular case.

Among various cases identified by Santilli (see above quoted papers and EHM-II), an example of *irregular Pauli-Santilli isomatrices* is given by

$$\widehat{\sigma}'_1 = \widehat{\sigma}_1, \quad \widehat{\sigma}'_2 = \widehat{\sigma}_2, \quad \widehat{\sigma}'_3 = w\widehat{\sigma}_3, \tag{3.213}$$

where w is a real number that *can assume the value zero* (e.g., for gravitational singularities, see next chapters), with isocommutation rules and isoeigenvalues

$$[\widehat{\sigma}'_i, \widehat{\sigma}'_j] = \widehat{\sigma}'_i T \widehat{\sigma}'_j - \widehat{\sigma}'_j T \widehat{\sigma}'_i = i C_{ijk} \widehat{\sigma}'_k, \quad C_{ijk} = \text{Diag.}(1, w, w), \quad (3.214)$$

$$\widehat{\sigma}'^2 T |\widehat{s}\rangle = \sum_k \widehat{\sigma}'_k T \widehat{\sigma}'_k T |\widehat{s}\rangle = (2 + w^2) |\widehat{s}\rangle, \quad (3.215)$$

$$\widehat{\sigma}'_3 T |\widehat{s}\rangle = \pm w |\widehat{s}\rangle. \quad (3.216)$$

The mutation of spin is then evident, as desired by Santilli and as needed by his physical and industrial applications (see next chapters).

Note that the irregular case can indeed be derived via a nonunitary transformation of the Lie case, but *six dimensional* (while that of the regular case was two dimensional, according to

$$U_{6 \times 6} \text{Diag.}(\sigma_2, \sigma_2, \sigma_2) U_{6 \times 6}^\dagger, \quad (3.217)$$

$$U_{6 \times 6} = \text{Diag.}(U_{2 \times 2}, U_{2 \times 2}, w U_{2 \times 2}), \quad (3.218)$$

that ensures the Lie-Santilli character of the isoalgebra.

Dirac-Santilli isoequation

Recall that *the conventional Dirac equation represents an electron under the “external” electromagnetic field of the proton* as well known, since a consistent extension of Dirac’s equation to the two-body system constituted by the H-atom has not been achieved to this day. In this case, all conventional intrinsic characteristics of particles are preserved and, therefore, there are no mutations. In this case, we have ordinary “particles” characterized by the Lorentz-Poincaré symmetry (3.75) with generators (3.76) and commutation rules (3.77)–(3.79).

By comparison, *the Dirac-Santilli isoequation represents an isoelectron under “external” electromagnetic and contact nonpotential interactions*, as necessary for the synthesis of the neutron from protons and electrons occurring in stars and studied in Chapter 6, since this case the wavepackets of the proton and electron are in conditions of mutual penetration, thus causing additional non-Hamiltonian interactions and related isorenormalizations.

Since the electron in vacuum has spin 1/2, the symmetry needed for the characterization of the isoelectron is given by the isotopy of the spinorial covering of the Lorentz-Poincaré symmetry, first studies by Santilli during his visit at the JINR in Dubna, Russia, Communication number E4-93-252 (1993), published in the 1995 paper [90], and today known as *Santilli isospinorial covering of the Lorentz-Poincaré symmetry*, that we write

$$\widehat{\Pi}(3.1) = \widehat{S}\widehat{L}(2.c) \times \widehat{T}(4) \times \widehat{T}(1) \quad (3.219)$$

with generators

$$\widehat{\Pi}(3.1) : \widehat{J}_k, \widehat{K}_k = (\widehat{G}_k)T(\widehat{G}_4)/2, \quad k = 1, 2, 3, \quad \widehat{P}_i, \quad i = 1, 2, 3, 4, \quad \widehat{I}, \quad (3.220)$$

and the same commutation rules as in Eqs. (3.77)–(3.79).

By comparing isosymmetries (3.219) and (3.75), it is evident that $\widehat{SL}(2.c)$ is the isospinorial covering of $\widehat{SO}(3.1)$, $\widehat{T}(4)$ continues to represent isotranslations as in Eqs. (3.88), and $\widehat{T}(1)$ continues to represent isotopic transforms as in Eq. (3.90).

Recall that, contrary to popular beliefs, Santilli has discovered a fundamental 11-th symmetry of the conventional Minkowskian spacetime used for grand unification, operator gravity and other important advances. Consequently, the Lorentz-Poincaré symmetry $P(3.1)$, its isotopic covering $\widehat{P}(3.1)$ and its isospinorial covering $\widehat{\Pi}(3.1)$ are all *eleven dimensional*.

The characterization of isosymmetry (3.219) requires two isospaces and related isounits, one for the mutation of spacetime (st) with *spacetime isounit* \widehat{I}_{st} and one for the mutation of the two-dimensional complex unitary spin space with *spin isounit* I_{spin} . From the positive-definiteness of these isounits, we assume the following diagonal realization (and leave very intriguing off-diagonal realizations to interested reader, see EHM-II)

$$\widehat{I}_{st} = 1/T_{st} = \text{Diag.}(n_1^2, n_2^2, n_3^2, n_4^2), \quad I_{spin} = 1/T_{spin} = \text{Diag.}(s_1^2, s_2^2). \quad (3.221)$$

As for the Pauli-Santilli isomatrices, we have the following two cases:

CASE I: Dirac-Santilli isoequation without spin mutation

Let $|e\rangle$ be the eigenstates of the conventional Dirac equation on the conventional Hilbert space over the field of complex numbers for the representation of an *electron*, and consider the following nonunitary transforms

$$U_{4 \times 4} U_{4 \times 4}^\dagger = \widehat{I}_{st}, \quad U_{2 \times 2} U_{2 \times 2}^\dagger = I_{spin}. \quad (3.222)$$

The isostate on the iso-Hilbert space over the isofield of complex numbers representing the *isoelectron*. In this case is then defined by

$$|\widehat{e}\rangle = U_{4 \times 4} |e\rangle. \quad (3.223)$$

The simplest possible version of the *regular Dirac-Santilli isoequation* on iso-Minkowski space for the characterization of the isoelectron is given by

$$\begin{aligned} U_{4 \times 4} (\gamma^k (p_k - ieA_k) - im'C) |e\rangle U_{4 \times 4}^\dagger = \\ \left(\widehat{G}^k T_{4 \times 4} (\widehat{p}_k - \widehat{(ieA_k)}) - \widehat{(im'C)} \right) T_{4 \times 4} |\widehat{e}\rangle = \\ (\widehat{\gamma}^k (\widehat{p}_k T_{4 \times 4} - ieA_k) - im'C) |\widehat{e}\rangle = 0, \quad (3.224) \end{aligned}$$

$$\widehat{G}^k = \widehat{\gamma}^k \widehat{I}_{st}, \quad \widehat{\gamma}^k = U_{4 \times 4} \gamma^k U_{4 \times 4}^\dagger, \quad (3.225)$$

$$\{\widehat{\gamma}^i, \widehat{\gamma}^j\} = U_{4 \times 4} \{\gamma^i, \gamma^j\} U_{4 \times 4}^\dagger = \widehat{\gamma}^i T_{4 \times 4} \widehat{\gamma}^j + \widehat{\gamma}^j T_{4 \times 4} \widehat{\gamma}^i = \widehat{m}^{ij}, \quad (3.226)$$

where the $\widehat{\gamma}$'s are the *regular Dirac-Santilli isomatrices* and \widehat{m}^{ij} is the isometric of the Minkowski-Santilli isospace.

It is easy to prove that isogenerators (3.220) realized via isogammas (3.225) verify all isocommutators (3.77)–(3.79) and the interested reader is encouraged to verify. Note that, in this case, no isotopy for the spin is needed because automatically provided by the assumed spacetime isotopy, resulting in a new realization of the regular Pauli-Santilli isomatrices, as the reader is suggested to verify. In any case, the spin isotopy can indeed be added, but has to preserve the spin 1/2 by assumption of the case considered, thus being inessential.

CASE II: Dirac-Santilli isoequation with spin mutation

This is the most important case for the synthesis of the neutron from a proton and an electron inside stars studied in Chapter 6, because the latter synthesis requires a mutation of spin.

In this case, we have the irregular realization of Eqs. (3.203), first identified by Santilli in the above quoted paper of 1993–1995, today known as *irregular Dirac-Santilli isoequation*, that can be written:

$$\widehat{G}^k T_{4 \times 4} (\widehat{p}_k - \widehat{ieA}_k) - \widehat{im'C} T_{4 \times 4} |\widehat{e}\rangle = (\widehat{\gamma}^k (\widehat{p}_k T_{4 \times 4} - ieA_k) - im'C) |\widehat{e}\rangle = 0, \quad (3.227)$$

$$\widehat{G}^k = \widehat{\gamma}_k \widehat{I}_{st} = n_k^{-1} \gamma^k \widehat{I}_{st}, \quad k = 1, 2, 3, \quad \widehat{G}^4 = \widehat{\gamma}_4 \widehat{I}_{st} = n_4^{-1} \gamma^4 \widehat{I}_{st}, \quad (3.228)$$

$$\{\widehat{\gamma}^i, \widehat{\gamma}^j\} = \widehat{m}^{ij}. \quad (3.229)$$

In this case, the *orbital isosymmetry* $\widehat{SO}(3)$ of the isoelectron is characterized by the generators and related isocommutation rules

$$\widehat{L}_1 = \widehat{r}_2 T \widehat{p}_{3_2} = \widehat{r}_3 T \widehat{p}_1, \quad \widehat{L}_3 = \widehat{r}_1 T \widehat{p}_2, \quad (3.230)$$

$$[\widehat{L}_1, \widehat{L}_2] = n_3^2 \widehat{L}_3, \quad [\widehat{L}_2, \widehat{L}_3] = n_1^2 \widehat{L}_1, \quad [\widehat{L}_3, \widehat{L}_1] = n_2^2 \widehat{L}_2, \quad (3.231)$$

with isoeigenvalues

$$\widehat{L}^2 T |\widehat{e}\rangle = (n_1^2 n_2^2 + n_2^2 n_3^2 + n_3^2 n_1^2) |\widehat{e}\rangle, \quad (3.232)$$

$$\widehat{L}_3 T |\widehat{e}\rangle = \pm (n_1 n_2) |\widehat{e}\rangle, \quad (3.233)$$

Note that the above particular realization of the isogroup $\widehat{SO}(3)$ is also locally isomorphic to the conventional $SO(3)$ group (because the n 's are positive-definite).

From generators (3.201), the *isotopic formulation of the spin* of the isoelectron is given by

$$\hat{J}_1 = (\hat{G}_2)T(\hat{G}_3)/2, \quad \hat{J}_2 = (\hat{G}_3)T(\hat{G}_1)/2, \quad \hat{J}_3 = (\hat{G}_1)T(\hat{G}_2)/2, \quad (3.234)$$

$$[\hat{J}_1, \hat{J}_2] = n_3^{-2} \hat{J}_3, \quad [\hat{J}_2, \hat{J}_3] = n_1^{-2} \hat{J}_1, \quad [\hat{J}_3, \hat{J}_1] = n_2^{-2} \hat{J}_2, \quad (3.235)$$

with isoeigenvalues

$$\hat{J}_2|\hat{e}\rangle = (1/4)(n_1^{-2}n_2^{-2} + n_2^{-2}n_3^{-2} + n_3^{-2}n_1^{-2})|\hat{e}\rangle, \quad (3.236)$$

$$\hat{J}_3T|\hat{e}\rangle = \pm(1/2)(n_1^{-1}n_2^{-1})|\hat{e}\rangle \quad (3.237)$$

illustrating the spin mutation *desired* by Santilli. Note that the eigenvalues of the spin, not only are no longer 1/2, but they are generally no longer constant to represent the electron when in the core of a collapsing star, or other extreme internal conditions, under which the preservation of the quantum value 1/2 is a pure unverified belief.

Note that the isocommutation rules of $\hat{\Pi}$ are the same as those of \hat{P} (3.1), Eqs. (3.77)–(3.79), as the reader is encouraged to verify and that, despite the indicated differences, Π (3.1) is isomorphic to the conventional spinorial symmetry Π (3.1). In particular, the above isotopic $SU(2)$ -spin remains isomorphic to $SU(2)$, of course, at the abstract, realization-free level.

Additional mutations characterized by the Dirac-Santilli isoequation are those of the magnetic moment μ and electric dipole moment d , whose derivation has been worked out by Santilli in the above quoted 1993–1995 paper via a simple isotopy of the conventional derivation, resulting in the isolaws valid for the case of an axial symmetry along the third axis

$$\hat{\mu} = \mu(n_4/n_3), \quad (3.238)$$

$$\hat{d} = d(n_4/n_3). \quad (3.239)$$

The above laws provide a quantitative geometric representation of the well known semiclassical property recalled earlier that the deformation of a charged and spinning sphere necessary implies an alteration of its magnetic and electric moments. In particular, we have a decrease (increase) of the magnetic moment when we have a prolate (oblate) deformation.

It is an instructive exercise for the interested reader to verify that the above realization of the above irregular Dirac-Santilli isoequation *cannot* be constructed via a nonunitary transform of the conventional Dirac equation as for the regular case, but requires special maps.

3.11.R Direct universality and uniqueness of hadronic mechanics

The following properties are important for an understanding of the verifications and applications of hadronic mechanics:

1) Hadronic mechanics has been proved to be “directly universal,” namely, admitting as particular cases all possible generalizations of quantum mechanics with brackets of the time evolution characterizing an algebra as defined in mathematics (universality), directly in the frame of the experimenter, thus avoiding any coordinate transformation (direct universality). This property is a consequence of the fact that Santilli’s Lie-admissible algebras (Section 2.8) are the most general possible algebras admitting as particular cases all possible algebras as conventionally understood in mathematics.

2) All possible true generalizations of quantum mechanics, namely, those outside its classes of unitary equivalence but preserving an algebra in the brackets of the time evolution, are particular cases of hadronic mechanics.

3) Any modification of hadronic mechanics for the intent of claiming novelty, such as the formulation of basic laws via conventional mathematics, verifies the Theorems of Catastrophic Inconsistencies of Nonunitary Theories.

Note that the above direct universality applies not only for nonrelativistic but also for relativistic hadronic mechanics.

Yet another aspect studied in detail by Santilli for years is whether the structure of hadronic mechanics is unique or there exist *inequivalent* nonunitary generalizations of quantum mechanics that are equally invariant over time. The result of this study is that hadronic mechanics is indeed the sole mechanics verifying the conditions indicated (nonunitary time invariant structure).

As an example, in his original proposal to build hadronic mechanics, Santilli classified all possible modifications of the associative product AB of two matrices A, B via the use of a fixed matrix with the same dimension,

$$AB \rightarrow A\hat{\times}B = ATB, TAB, ABT, \quad (3.240)$$

and concluded that the only acceptable isotopy is the form ATB , because the alternative forms TAB (ABT) violate the right (left) distributive and scalar laws, thus preventing the use of an algebra in the enveloping operator algebras with consequential catastrophic inconsistencies. A reason for the uniqueness is that the only possible representation of contact non-Hamiltonian interactions verifying the condition of time invariance is that via Santilli isounit. Invariance then follows since the unit is the basic invariant of all theories. Nonequivalent generalizations of quantum mechanics must then use a representation of non-Hamiltonian effects other than that via the isounit, by activating the Theorems of Catastrophic Inconsistency of Nonunitary Theories.

3.11.S *EPR completion of quantum mechanics, hidden variables and all that*

Santilli has repeatedly presented hadronic mechanics as a form of “completion” of quantum mechanics in honor of Einstein, Podolsky and Rosen who expressed historical doubts on the completeness of quantum theories. In fact, *hadronic mechanics provides an explicit and concrete realization of hidden variables λ that are realized via the isotopic operator T according to the isoassociative eigenvalue equations*

$$H\lambda|\widehat{\psi}\rangle = H\widehat{\times}|\widehat{\psi}\rangle = HT|\widehat{\psi}\rangle = E|\widehat{\psi}\rangle. \quad (3.241)$$

The hidden character emerges from the fact that, at the abstract, realization-free level, there is no distinction between the conventional associative action of the Hamiltonian on a Hilbert state and its isoassociative covering. In fact, at the abstract level one can write the modular action in the abstract right-associative form “ $H|\widehat{\psi}\rangle$ ” for both quantum and hadronic versions, thus illustrating the truly “hidden” character of said variables.

More generally, **all branches of hadronic mechanics preserve the abstract axioms of quantum mechanics and merely provide broader realizations of the same axioms.**

Santilli has also studied the nonunitary covering of Bell’s inequalities and shown that, contrary to the quantum case, they do admit indeed a classical counterpart, thus altering the entire field of local realism [107].

3.11.T *Operator isogravity*

As indicated in Chapter 1, one of the biggest scientific imbalances of the 20th century physics has been the absence of a consistent quantum formulation of gravity, since the quantization of the Riemannian representation is afflicted by a litany of inconsistencies. In particular, the noncanonical character of the classical formulation requires, for consistency, a nonunitary operator counterpart, thus activating the Theorems of Catastrophic Inconsistencies of Nonunitary Theories.

Santilli studied for decades the problem of a consistent operator form of gravity without any publication. He finally presented his solution at the 1994 M. Grossmann Meeting on Gravitation held at Stanford Linear Accelerator Center [88]. See also EHM Volumes I and II and paper [91].

Santilli’s argument is essentially the following. The impossibility of achieving a consistent operator form of gravity is due to *curvature*, since the latter requires a noncanonical classical structure with consequential nonunitary operator formulation and related catastrophic inconsistencies.

Hence, Santilli formulated his **isogravitational theory** indicated in Section 3.10H in which Riemannian line elements are identically reformulated in the Minkowski-Santilli isospace via the decomposition of the metric $g(r) = T_{gr}(r)m$,

Eq. (3.100), where m is the Minkowski metric, and T_{gr} is the gravitational isotopic element. The formulation of the isometric $\hat{m} = T_{\text{gr}}(r)m$ with respect to the isounit as the *inverse* of the gravitational isotopic element, $\hat{I}_{\text{gr}} = 1/T_{\text{gr}}$, eliminates curvature, thus restoring unitarity on the Hilbert-Santilli isospace over isofields with isounits \hat{I}_{gr} .

This discovery was made possible by the unification of the Minkowskian and Riemannian geometries into the Minkowski-Santilli isogeometry presented in detail in EHM Volume I, as well as in memoir [104].

Following the above advances, the achievement of a consistent operator formulation of gravity was elementary. In fact, **relativistic hadronic mechanics includes gravity without any modification of its structure via the mere interpretation of its isotopic element as being that of gravitational nature.** Again, the procedure merely requires the factorization of the Minkowski metric m from any given Riemannian metric $\hat{m}(r) = T_{\text{gr}}(r)m$, such as for the Schwartzschild's metric, and the use of relativistic hadronic equations. As an illustration, the procedure yields the Dirac-Santilli isoequation (3.203), for which the anticommutation of the isogamma matrices yields precisely the Schwartzschild's metric, Eq. (3.204).

3.11.U *Iso-grand-unification*

There is no doubt that one of Santilli's biggest scientific contributions has been the achievement of the first axiomatically consistent grand unification of electroweak and gravitational interactions without pre-existing comparisons for consistency, mathematical beauty and physical content, to the Foundation's best knowledge (the indication of equally consistent grand unification is encouraged for comparative listing in this section). Here are summary comments released by Santilli:

The achievement of a consistent grand unification has been, by far, the most complex research problem I ever confronted due to the vastity and diversification of the required knowledge. Also, the more I worked at a solution, the bigger the problems with consequential widening of the field. Without any expectation that colleagues would agree, my conclusions following decades of work at the problem are the following:

1) **Antimatter.** *I had to reject all preceding attempts at a grand unification, including that by Einstein, because of unsurmountable inconsistencies caused by antimatter. In fact, electroweak theories beautifully represent matter and antimatter, while a Riemannian gravitation does not, as nowadays well known. Only after achieving the isodual mathematics and related isodual theory of antimatter I was finally able to resolve these inconsistencies with a judicious decomposition of electroweak theories into advanced solutions and their isoduals with a correspond-*

ing gravitational and isodual counterpart allowing full democracy between matter and antimatter at all levels.

2) **Curvature.** After years of failed attempts along orthodox lines, I had to admit to myself that the representation of gravity via a curved spacetime renders any grand unification simply impossible. This was due to a litany of inconsistencies originating from attempting the combination of a theories structurally flat in spacetime, such as electroweak theories, and a gravitational theory that is structurally curved in spacetime. In particular, any reformulation of electroweak theories on a curved manifold to achieve geometric compatibility with gravitation, lead to unsurmountable catastrophes, such as the loss of physical meaning of electroweak theories at the operator level. These inconsistencies were determinant for my decision to cross the scientific "Rubicon" and abandon curvature for a covering theory of gravitation without curvature. That generated the birth of isogravitation.

3) **Covariance.** A third litany of inconsistencies originated from the fact that electroweak theories are beautifully structured by gauge and spacetime symmetries, while gravitation had none. The use of the customary "covariance" adopted by gravitational studies throughout the 20th century caused additional catastrophic inconsistencies, such as the lack of physical meaning of electroweak theories due to the general impossibility to predict the same numerical values under the same conditions at different times. The resolution of this third class of inconsistencies required the laborious construction of the Lie-isotopic theory that, in turn, permitted the construction of the Lorentz-Poincaré-Santilli universal isosymmetry of isogravitation.

The combination of all my studies, including the various new mathematics, the isodual theory of antimatter, the Lie-isotopic theory and relativistic hadronic mechanics, then finally lead to the iso-grand-unification with an axiomatically consistent inclusion of mutually compatible electroweak and gravitational theories for matter and antimatter.

The final solution I proposed is so elementary to be deceptive, because I essentially introduced gravitation where nobody looked for, in the unit of electroweak theories. However, by looking in retrospect, I can say that the virtual entirety of my research was ultimately aimed at the achievement of an axiomatically consistent grand unification. The diversification and novelty of the research illustrates the complexity of the problem of grand unification beyond the level of biased academic views.

In fact, following decades of research, Santilli finally released his iso-grand-unification at the VIII Marcel Grossmann Meeting on Gravitation held in Jerusalem, Israel, in 1996 [110], as well as in related papers [94, 101]. The most comprehensive and updated presentation of the iso-grand-unification is available in the five volumes of HMMC.

3.11.V Acknowledgments

Jointly with the completion in 1997 of the formal construction of hadronic mechanics and its primary experimental verifications as well as applications in the 1997 paper [99], Santilli released a rather vast acknowledgment to all institutions, journals and colleagues who helped the, or were exposed to the construction of hadronic mechanics. The Foundation has retrieved the preprint and provides below the original version of the Acknowledgments since they had to be reduced in the published version by editorial request.

*SANTILLI ACKNOWLEDGMENTS FOR THE CONSTRUCTION
OF HADRONIC MECHANICS DATED 1996,*

released in the preprint “*Relativistic hadronic mechanics: nonunitary,
axiom-preserving completion of relativistic quantum mechanics,*”

R. M. Santilli, IBR preprint TH-06-25 (1996)

(for the final version, download the published version [99]).

It is a pleasant duty to express my sincere appreciation to th referees of Foundations of Physics for a very accurate control of the manuscript and for simply invaluable critical suggestions.

It is also a duty to express my appreciation to a number of institutions, journals and colleagues for hospitality and invaluable help during the laborious studies in the construction of hadronic mechanics and its verification conducted during the past three decades.

First, I would like to thank the following Institutions:

- *The University of Naples, Italy, where I conducted my undergraduate studies in physics for an unforgettable human and scientific experience. I want to remember and thank in particular my mathematics teacher Renato Caccioppoli for propagating to be his passion for mathematics that set the direction of the rest of my scientific life;*
- *The Department of Physics of the University of Torino, Italy, where I put the foundations of hadronic mechanics in the late 1960’s as part of my Ph.D. thesis;*
- *The Avogadro Institute in Torino, Italy, that gave me a chair in nuclear physics when quite young, with various students still remembering and tracing me down to this day;*
- *The Center for Theoretical Physics of the University of Miami, Coral Gables, Florida, where I had a very enjoyable stay during the academic year 1967–1978;*
- *The Department of Physics of Boston University where I taught, from prep courses to post Ph.D. Seminar courses in mathematics and physics, from 1968 to 1974;*

- The Center for Theoretical Physics of the Massachusetts Institute of Technology, where most background technical preparation was conducted in the mid 1970's, such as the papers on the existence and construction of a Lagrangian in field theory, the paper on the identification of gravitational and electromagnetic interactions, the preliminary versions of monographs published by Springer Verlag, and other studies;
- The Department of Mathematics of Harvard University, where the main papers proposing the construction of hadronic mechanics and numerous other works were written in the late 1970's and early 1980's under support from the U.S. Department of Energy;
- The Joint Institute for Nuclear Research, Dubna, Russia, for summer hospitality in recent years, where several papers were written, such as the crucial paper on isonumbers, genonumbers and their isoduals, the paper on the synthesis of the neutron first appeared as JINR Communication Number E4-93-352, and other papers;
- The Institute for High Energy Physics, Protvino-Sherpukov, Russia, also for summer hospitality in recent years, where the most innovative studies in gravitation were initiated;
- The International Center for Theoretical Physics in Trieste, Italy, for a short visit in 1992;
- CERN, Geneva, Switzerland, also for a short stay in 1992;
- The Institute for Basic Research on Harvard Grounds from 1982 to 1989 and then in Palm Harbor Florida from 1989 to present where the main research on hadronic mechanics has been conducted and continued to this day;

and numerous other Institutions for shorter stays.

I would like to express my appreciation for recent hospitality I received for presentations on various aspects of hadronic mechanics at the following meetings (up to 1996):

- Three Workshops on Lie-admissible Formulation, Harvard University, 1978–1981;
- International Conference on nonpotential interactions and their Lie-admissible treatment, University of Orleans, France, 1982;
- Nine Workshops on Hadronic mechanics from 1981 to present held at various institutions in the Boston, Area (USA), Belgrad (Yugoslavia), Patras (Greece), Como (Italy), London (England), Beijing (China), and other locations;
- International Workshop on Symmetry Methods in Physics, J.I.N.R., Dubna, Russia, July 1993;

- *Third International Wigner Symposium, Oxford University, Oxford, England, September 1993;*
- *International Conference, J.I.N.R., Dubna, Russia, June 1993;*
- *XVI-th (1993), XVII-th (1994) and XIX-th (1996) International Workshop on High Energy Physics and Field Theory, I.H.E.P., Protvino-Sherpukov, Russia, September 1993;*
- *International Conference on the Frontiers of Fundamental Physics, Olympia, Greece, September 1993;*
- *VI-th Seminar on High Temperature Superconductivity, J.I.N.R., Dubna, Russia, September 1993;*
- *Seventh Marcel Grossmann Meeting on General Relativity and Cosmology, Stanford University, Stanford, CA, U.S.A., July 1994;*
- *1996 Sanibel Symposium, St. Augustine, Florida, March 1995 and February 1996;*
- *First Meeting for the Saudi Association for Mathematical Sciences, Riyadh, Saudi Arabia, May 1994;*
- *International Conference on Selected Topics in Nuclear Structure, J.I.N.R., Dubna, Russia, July 1994;*
- *International Workshop on Differential Geometry and Lie Algebras, Thessaloniki, Greece, December 1994;*
- *HyMag Symposium, National High Magnetic Field Laboratory, Tallahassee, Florida, December 1995;*
- *International Workshop on new Frontiers in Gravitation, Istituto per la Ricerca di Base, Castle Prince Pignatelli, Monteroduni, Italy, August 1995;*
- *National Conference on Geometry and Topology, Iasi, Rumania, September 1995;*
- *International Symposium for New Energy, Boulder Colorado, April 1996;*
- *International Workshop on the Gravity of Antimatter and Anti-Hydrogen Atom Spectroscopy, Sepino, Italy, May, 1996;*
- *Workshop on Differential geometry, Palermo, Italy, June 1996;*
- *International Workshop on Polarized Neutrons, J.I.N.R., Dubna, Russia, June 1996.*

Special thanks are also due for the recent opportunity of delivering lectures or short seminar courses on the various aspects of hadronic mechanics at:

- *Moscow State University, Moscow, Russia, August 1993;*

- Estonia Academy of Sciences, Tartu, August 1993;
- Theoretical Division, J.I.N.R., Dubna, Russia, September 1993; August 1994; August 1995; August 1996;
- Ukrainian Academy of Sciences, Kiev, September 1993;
- Institute for Nuclear Physics, Alma Ata, Kazakhstan, October 1993;
- Institute for High Energy Physics, Protvino, Russia, June 1993, June 1994, June 1995;
- Theoretical Division, C.E.R.N, Geneva Switzerland, December 1994;
- Department of Mathematics, Aristotle University, Thessaloniki, Greece;
- Department of Mathematics, King Saud University, Riyadh, Saudi Arabia;
- Democritus Institute, Athens, Greece, December 1994;
- Institute of Nuclear Physics, Democritos University of Thrace Xanthi, Greece, December 1994;
- Institute for Theoretical Physics, Wien, Austria, December 1994;
- Department of Mathematics, University of Constanta, Romania, September 1995;
- Research Center COMSERC, Howard University, Washington, D.C., U.S.A. April, 1995;
- Department of Mathematics, Howard University, Washington, D.C., U.S.A., April 1995;
- The International Center for Theoretical Physics (ICTP), Trieste, Italy, 1992;
- Department of Nuclear Physics, University of Messina, Italy, June 1996;
- Department of Mathematics, University of Palermo, Italy, June 1996;
- Academia Sinica, Beijing, China, supper 1995;
- The Italian national Laboratories in Frascati, Italy, 1977;
- The Center for Theoretical Physics of the Massachusetts Institute of Technology, 1976;
- The Lyman Laboratory of Physics, Cambridge, MA, 1978, delivering a seminar course on the integrability conditions for the existence of a Lagrangian in Newtonian mechanics and field theory;
- The University of Illinois in Bloomington, 1968;
- Russian Academy of Sciences, Moscow, June 1996;

and other institutions in various countries. I have no word to express my sincere appreciation and gratitude to all colleagues at the above meetings or institutions for invaluable critical comments.

Additional thanks for the critical reading of parts of this paper are due to: M. Anastasiei, Yu. Arestov, A. K. Aringazin, A. K. T. Assis, M. Barone, Yu. Barishev, J. Ellis, T. Gill, J. V. Kadeisvili, A. U. Klimyk, A. Jannussis, N. Makhal-diani, R. Miron, M. Mijatovic, D. Rapoport-Campodonico, D. Schuch, G. T. Tsagas, N. Tsagas, C. Udriste, T. Vougiouklis, H. E. Wilhelm, and others.

Finally, this paper has been made possible by rather crucial publications appeared in the following Journals, here acknowledge with sincere appreciation:

- *Foundations of Physics*, for publishing: this memoir, the first after the achievement of axiomatic maturity in relativistic hadronic mechanics; the 1981 article on the apparent impossibility for quarks to be elementary at a time of widespread belief to the contrary; and several related articles in classical and operators studies not quoted for brevity;
- *Physical Review A*, for publishing the important article by Schuch on the need for nonunitary treatment of nonlinear operator systems;
- *Physical Review D*, for publishing the 1981 article on the need to verify the validity of Pauli's principle under nonconservative conditions due to external strong interactions; the 1978 article {3c} on the isotopies of electroweak interactions with a breaking of the gauge invariance; and other papers;
- *Hyperfine Interactions*, for publishing the paper on the prediction of a novel light emitted by antimatter;
- *Nuovo Cimento*, for the publication of: the 1967 article on the first Lie-admissibility in the physical literature; the 1983 article on the first isotopies of Minkowski spaces, the Lorentz symmetry and the special relativity the 1983 article {4f} on the first operator realization of isosymmetries via a lifting of Wigner's theorem; the 1982 article on the first Lie-admissible time-irreversible formulation of open strong interactions; the article on the first isotopies of $SU(3)$, article, the scattering theory, and several other seminal papers;
- *The (MIT) Annals of Physics*, for the publication of the 1976 articles on the integrability conditions for the existence and computation of a Lagrangian in field theory, the 1982 article on the crucial identification of the gravitational and electromagnetic fields from the primary electromagnetic origin of mass (that subsequently rendered unavoidable the prediction of antigravity), and others;
- *Journal of Physics G*, for publishing the 1981 articles on the rather crucial isominkowskian representation of the behavior of the meanlives of K - 0 with energy, and other papers;
- *Physica*, for publishing the 1985 article on the possibility of regaining convergent perturbative series for strong interactions, and others;

- *Physics Essays*, for publishing the 1992 article on classical realizations of Santilli's isogalilean relativity, and the article on the representation of the difference between cosmological redshifts of physically connected quasars and galaxies via Santilli's isospecial relativity, and others;
- *Communications in Theoretical Physics*, for publishing a number of crucial articles, such as the first article on the isotopic quantization of gravity, the first article on the isoquark theory, the first article on the isodual representation of antimatter, the first article on the paradox of quantum mechanics at the limit of gravitational singularities, and several others;
- *Annales de la Fondation Louis de Broglie*, for publishing the crucial articles on the limitations of current generalized theories, and others;
- *Revista Tecnica*, for the publication of articles on the isotopies of Newtonian, analytic and quantum mechanics;
- *Journal of Moscow Physical Society*, for the publication of the comprehensive 1993 article on the isotopies and isodualities of the Poincaré symmetry, including the universal symmetry of all possible Riemannian and Finslerian line elements, which is the single most important paper of these studies from which all results can be uniquely derived;
- *J.I.N.R. Rapid Communications* for the publication of the crucial 1993 article on the isotopies of $SU(2)$ -spin with the isopauli's matrices and the reconstruction of the exact isospin symmetry in nuclear physics;
- *International Journal of Quantum Chemistry*, for the publication of the crucial 1981 article on the application and experimental verification of hadronic mechanics to superconductivity, with the first attractive force among two identical electrons in singlet couplings at mutual distances smaller than their coherent length;
- *Chinese Journal of Systems Engineering and Electronics*, for the publication of the crucial 1995 article on the isotopies of the spinorial covering of the Poincaré symmetry and of Dirac's equations, with application to the synthesis of the neutron from protons and electrons only, and other articles;
- *Mathematical Methods in Applied Sciences*, for the publication of the recent comprehensive study {5g} by Kadeisvili on the Lie-Santilli isothory and related methods;
- *Rendiconti Circolo Matematico di Palermo* for the publication of an entire 1996 issue of of their *Supplemento* entirely dedicated to the new mathematics underlying hadronic mechanics;
- *Acta Applicandae Mathematica* for the publication in 1995 of th crucial application of hadronic mechanics to Bell's inequality, the isotopies of the $SU(2)$ spin symmetry and all that;

- *The Indian Mathematical Society, for the publication of numerous seminal papers in pure and applied mathematics at the foundation of hadronic mechanics; and other Journals.*

Particular thanks are additionally due to all past and present Editors of the *Hadronic Journal and Algebras, Groups and Geometries* for their continued encouragement, support and control of various publications quoted in this paper.

Additional thanks are due to the participants, editors and publishers of the *Proceedings of some eighteen international workshops and conferences held in the field of hadronic mechanics in the USA, Europe, and China* resulted in a total of over thirty volumes, which are too numerous to mention here individually.

I must also express my utmost gratitude to G. F. Weiss, S. Smith and P. Fleming, staff of our Institute for Basic Research in Palm Harbor, Florida, and numerous other members and visitors through the years, for simply invaluable help, assistance and control in the preparation of this manuscript.

It is also my pleasant duty to thank several colleagues for their invaluable contributions in the construction of the hadronic mechanics, particularly during the early years of its study, including: S. Okubo, H. C. Myung, R. Mignani, F. Cardone, A. K. Aringazin, A. Kalnay, A. O. E. Animalu, D. Schuch, T. L. Gill, Gr. Tsagas, D. S. Sourlas, J. V. Kadeisvili, E. B. Lin, M. Nishioka, A. Jannussis, G. Eder, J. Fronteau, M. Gasperini, D. Brodimas, P. Caldirola, M. Mijatovic, Y. Prigogine, K. Popper, B. Veljanoski, A. Tellez-Arenas, and others.

I cannot close these Acknowledgments without expressing my appreciation to the American, British, Italian, Swedish, French, German, Russian, Chinese physical and other societies for their role in the construction of hadronic mechanics. On my side, I would like to indicate that when facing truly fundamental structural advances of pre-existing knowledge as it is the case here, the "burden of proof" on their validity belongs to the author(s) and definitely not to the societies, since their historical role is that of exercising caution for the very protection of science. On the other side, scientific societies are suggested to exercise tolerance when attacked for insufficient scientific democracy at the time when the battle for new scientific vistas reaches its climax.

I cannot close these Acknowledgments without expressing my deepest appreciation to the United States of America for being so generous to me and my family, by permitting me to realize my scientific dreams on hadronic mechanics as well as my personal dreams in the American way of life, sports cars and boats, generosity that has caused in me an unbounded allegiance.

It is a truism to say that without my conduction of research in the U.S.A., hadronic mechanics would not have been completed and established because, even though its main lines had been conceived in Italy, the realization of the above indicated "burden of proof" required "experimental verifications and novel industrial applications relevant to society" that would have been of difficult realization

elsewhere because they must be achieved nowadays outside academia whenever dealing with basic advances over pre-established doctrines, as well known to insiders.

On my part, I considered myself a "special immigrant" because: I came here: from a rich Italian family, my father Ermanno Santilli being an Italian Medical Doctor and my grandfather Ruggero Santilli being an Italian industrialist; after achieving in Europe the highest possible education in mathematics physics and chemistry; and while being the recipient of a chair in nuclear physics at the Avogadro Institute in Torino.

The construction and proof of hadronic mechanics were possible "by" (rather than "in") the U.S.A. amidst incredible, well known and documented academic obstructions (at time reaching true levels of hysteria against the surpassing of beloved old doctrines), because of: the inspired values of the U.S. Constitution, the best throughout history I ever read; the crucial democracy of its Institutions; and its unique multitude of overlapping social, governmental and industrial structures offering people a variety of ways to realize their dreams, but only following fierce determination, relentless commitment and true values.

Most special thanks are finally due to my wife Carla for her grace, class, patience and support in enduring predictable obstructions in the conception, completion and proof of hadronic mechanics.

Needless to say, I am solely responsible for the content of this paper owing to the numerous changes occurred during the preparation of the final version.



Chapter 4

SANTILLI DISCOVERIES IN CHEMISTRY AND BIOLOGY

4.1 Introduction

4.1.A *Lack of exact character of quantum mechanics for the hydrogen molecule (1978)*

As recalled in Section 1.9, quantum chemistry has indeed permitted the achievement during the 20th century of historical advances in material and equipment of our daily lives. Nevertheless, it is the fate of all theories to admit broader formulations rendered necessary by insufficiencies of pre-existing theories or by the advent of basically new conditions for which preceding theories were not intended for.

As set in history, quantum mechanics provided a representation of the structure of *one* hydrogen atom with an incredible accuracy, essentially to the desired decimal value. However, when studying *two* hydrogen atoms bonded in the hydrogen molecule $H_2 = H - H$ (where the dash “-” represents valence bond hereon), the preceding accuracy is lost due to the historical inability to represent a residual 2% of the binding energy from unadulterated quantum axioms, with much greater inaccuracies when passing to more complex molecules.

The above insufficiency of quantum mechanics for the hydrogen molecule was one of the motivations for the proposal by Santilli in 1978 to construct the hadronic covering of quantum mechanics, as per the historical paper [44] hereon referred to as the “original proposal of 1978”.

4.1.B *Insufficiencies of the quantum chemical notion of valence (1978)*

Since nuclei do not participate in any appreciable way to molecular bonds, it is evident that the lack of exact character of quantum mechanics for the structure of the $H - H$ molecule is due to the *valence bond*, namely, to the appearance

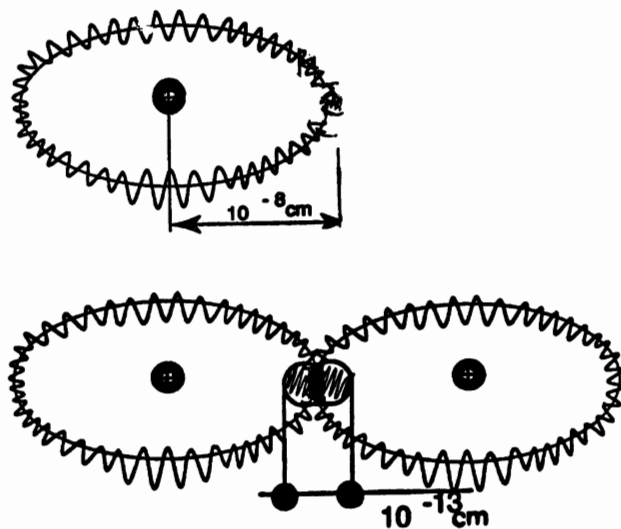

Figure 4.1. The original drawing used by Santilli to illustrate the physical differences between the hydrogen atom and the hydrogen molecule, the former consisting of point-like particles at large mutual distances, and the latter having additional short range interactions necessary for the valence bond. These physical differences illustrate the exact character of quantum mechanics for large mutual distances as in the hydrogen atom and its merely approximate character for additional short distance interactions as in the hydrogen molecule.

of interactions and effects at the short distance conditions of the valence bond beyond the descriptive capabilities of quantum mechanics (see Figure 4.2).

For these and other reasons, Santilli never accepted the quantum chemical notion of valence bonds since his graduate studies in the 1960s at the University of Torino, Italy. In particular, as indicated in Section 1.9, Santilli always considered said notion as a pure nomenclature without quantitative scientific content because, to achieve the latter, the valence must verify the following:

CONDITION 1: Identify explicitly, that is, with equations, the *force* between a pair of valence electrons and its physical or chemical origin;

CONDITION 2: Prove that the above identified force is indeed *attractive*; and

CONDITION 3: The above identified attractive force must *verify experimental evidence* on molecular binding energies and other data.

Quantum chemistry cannot verify the above conditions because *identical electrons repel each other, and certainly they do not attract each other, according to quantum mechanics and chemistry*. Hence, Santilli sets his research objective of building a covering of quantum chemistry more adequate for the representation of the valence and other chemical features.

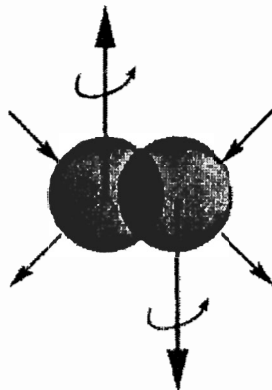

Figure 4.2. A reproduction of the original picture used by Santilli on the valence electrons bond in single coupling illustrating the need for a theory that is nonlinear (in the wavefunction), non-local (of integral type) and nonunitary (because of contact nonpotential type not representable with a Hamiltonian). Quantum chemistry is strictly linear, local-differential and Hamiltonian, thus being structurally unable to provide a quantitative representation of the valence. By comparison, the covering hadronic chemistry has the needed nonlinear, nonlocal and nonunitary structure beginning with its mathematical foundation.

The insufficiency of the quantum notion of valence was the central motivation for the construction of hadronic mechanics and chemistry, as stressed in the Original Proposal of 1978 quoted above, to such an extent that two intersecting circles were assumed as the first logo of the *Institute for Basic Research*.

4.1.C *Insufficiencies of screened Coulomb potentials (1978)*

The impossibility for the conventional formulation of quantum chemistry to provide an exact representation of molecular binding energies and other data became clear in the second part of the 20th century. The resolution of the insufficiencies was then attempted via the so-called *screening of the Coulomb potential*, that is, the multiplication of the fundamental Coulomb potential between two valence electrons, $V = e^2/r$, by an arbitrary function $f(r)$ of completely unknown origin, resulting in “screened potentials” of the type

$$V'(r) = f(r) \frac{e^2}{r}. \quad (4.1)$$

The arbitrary function $f(r)$ was fitted from experimental data; screened Coulomb potentials did achieve the intended accuracy in the representation of binding energies; and quantum chemistry was confirmed as being exactly valid for molecular structures.

Despite the above success, Santilli never accepted screened Coulomb potentials for the following reasons:

1) The map from the Coulomb potential to its screened form requires a *nonunitary transform*

$$V(r) = \frac{e^2}{r} \rightarrow V'(r) = f(r) \frac{e^2}{r} = UV(r)U^\dagger, \quad (4.2)$$

$$UU^\dagger = f(dr) \neq I. \quad (4.3)$$

Consequently, the screening of the Coulomb law causes major departures from the unitary structure of quantum mechanics.

2) The Coulomb potential is a fundamental *invariant* of quantum mechanics. Consequently, its screening causes the breaking of the fundamental Galilei symmetry under which conditions quantum mechanics cannot any longer be exact.

3) It is well known that the *quantum of energy* is solely possible for the Coulomb law and that any quantization of the energy is impossible for screened potentials.

For these and other reasons, Santilli always rejected as inappropriate the name of “quantum chemistry” for screened Coulomb potentials.

In the scientific reality, it is clear that the screening of the Coulomb law is outside the class of unitary equivalence of quantum mechanics and chemistry; hadronic mechanics and chemistry are indeed the broadest possible nonunitary coverings of quantum theories; and, therefore, screened potentials are a particular case of the nonunitary class of interactions treated by hadronic mechanics. To put it explicitly, Santilli showed that hadronic chemistry was already in use by the end of the 20th century, although under the disguised name of “quantum” chemistry.

As one can verify, Santilli’s Original Proposal of 1978 was centered in the construction of a *nonunitary* covering of quantum mechanics also in view of the nonunitary character of map (4.2). Hence, the insufficiencies of quantum chemistry had a crucial role for the conception, development and verification of hadronic mechanics.

4.1.D Classification of hadronic chemistry (2000)

Immediately following the achievement in 1996 of mathematical maturity of hadronic mechanics, Santilli passed to applications of the new mechanics in chemistry because some of the most important experimental verifications and industrial applications of the new discipline was expected precisely in chemistry. These studies produced a covering of quantum chemistry known as *hadronic chemistry* comprising the following branches:

QUANTUM CHEMISTRY: assumed to be exactly valid for all mutual distances of particles bigger than $1 \text{ fm} = 10^{-13} \text{ cm}$;

ISOCHEMISTRY: characterized by a Lie-isotopic, time invariant, axiom-preserving, nonunitary covering of quantum chemistry formulated over Hilbert-San-

tilli isospaces over Santilli isofields for the representation of *isolated and reversible chemical structures and processes*;

GENOCHEMISTRY: characterized by a Lie-admissible, time irreversible covering of isochemistry formulated on Hilbert-Santilli genospaces over Santilli geno-fields for the representation of *irreversible chemical structures and processes*;

HYPERCHEMISTRY: characterized by a multi-valued covering of genochemistry for the representation of *organic structures and processes*;

ISODUAL ISO-, GENO- AND HYPER-CHEMISTRY: characterized by the isodual map (2.9) for the description of the *chemistry of antimatter*.

4.1.E Basic literature

Hadronic mechanics achieved mathematical maturity in a special issue of the *Rendiconti Circolo Matematico Palermo* of 1996 [93] entirely dedicated to Santilli's new mathematics, which issue also presented the first formulation of Santilli hypermathematics needed for biology. The main historical reference in hadronic chemistry is the 2001 monograph on *Foundation of Hadronic Chemistry* hereon referred to as FHC [18]. Subsequent studies can be found in *Hadronic Mathematics Mechanics and Chemistry*, hereon referred to as HMMC Volumes I, II, III, IV and V [20–24]. Santilli's discovery of new magnecular fuels with complete combustion, and related industrial realization, can be found in [118]. The main references on Santilli's studies in biology can be found in the monographs [16].

The Australian biologist Chris R. Illert provided important input in Santilli's studies in biology, on which we quote the joint monograph [15].

Various, additional, specialized papers will be identified during the course of our presentation.

It should be stressed that in this chapter we shall present for notational simplicity only the *projection* of Santilli's hadronic chemistry on a conventional Hilbert space over a conventional field, so as to avoid the complex notations of the full hadronic treatment. The understanding is that only the latter treatment resolves the Theorems of Catastrophic Inconsistencies of Section 3.7. Therefore, readers without a technical knowledge of hadronic mechanics are suggested to abstain from venturing judgments on the content of this chapter so as to avoid a clear illusion of knowledge.

4.2 Hadronic Chemistry

4.2.A *Animalu-Santilli Cooper pair (1995)*

The application and experimental verification of hadronic mechanics that anticipated hadronic chemistry is given by the first quantitative representation in history of the *structure* of the Cooper pair in superconductivity. As it is well known, quantum mechanics does provide a consistent representation of super-

conductivity, but via an *ensemble* of Cooper pairs considered point-like, without any description on how identical electrons could bond themselves into the Cooper pair, since electrons repel each other according to quantum mechanics.

A dominant model in the quantum literature in the field is that based on the interplay of entities called “phonons” that, however, are known to have a purely mathematical character since no “phonon” has ever been discovered, or can at least be formulated, within the context of elementary particle physics.

Independently from this basic insufficiency, the quantum description of superconductivity has long surpassed the boundaries of quantitative predictions for the increase of superconductive temperatures, recent efforts being essentially conducted on grounds of trials and errors without any mathematical and/or physical and/or chemical guiding foundations.

Hadronic mechanics permitted the first quantitative representation of the structure of the Cooper pair without any use of hypothetical “phonons”, in a way fully compatible with available experimental data, as well with remarkable predictive capacity for bigger superconductive temperature.

The origin of the bond between the identical electrons of the Cooper pair resulted to be the *contact nonpotential interactions* occurring in the deep mutual penetration and overlapping of the wavepackets of the electrons, as first identified by Santilli in the Original Proposal of 1978. The trigger for the bond of the electrons resulted to be due to the cuprate as well as other nuclei. The nonpotential character of the interactions rendered mandatory the use of the sole invariant mechanics for their representation, hadronic mechanics.

In this way, the hypothetical “phonons” providing a hypothetical exchange bond between electrons that repel each other according to quantum laws, resulted as being a mere mathematical mechanism for the approximation of contact nonpotential interactions beyond any capability of quantum representations. The main gain in the process is a dramatic increase of the predictive capacities to increase the superconductive temperature, all the way to the prediction of a new electric current based on the transfer of Cooper pairs or, more appropriately, valence electrons pairs in singlet bond, since the latter have no appreciable magnetic moment, with evident dramatic decrease of the resistance.

Among a large number of publications in the field, we quote the historical paper by A. O. E. Animalu and R. M. Santilli of 1995 [92]. Vast studies in the field were conducted by Animalu and reviewed in details in HMMC, Volume V, where Santilli gave the name of *Animalu isosuperconductivity* to the resulting new discipline.

4.2.B Santilli-Shillady strong valence bond (1999)

The central problem of molecular chemistry is the verification of Conditions 1, 2, 3 of Section 4.1. This objective was achieved by R. M. Santilli and the American chemist D. D. Shillady in the historical paper of 1999 [113].

To provide a conceptual outline, consider the conventional quantum mechanical equation in relative coordinates and reduced mass for two electrons in singlet coupling as per Figure 4.2,

$$\left(\frac{p^2}{m} + \frac{e^2}{r}\right)\psi(r) = E\psi(r), \quad (4.4)$$

where m is the electron mass. The above equation shows the *repulsive* Coulomb force between the *point-like charges* of the electrons. But the electrons have *extended wavepackets* of the order of 1 fm whose mutual penetration, as necessary for the valence bond, causes *nonlinear, nonlocal and nonpotential interactions* at the foundations of hadronic mechanics (see the preceding chapter). The only known possibility for an invariant representation of these interactions is to exit from the class of unitary equivalence of Eq. (4.4) via an isounitary transformation (see Section 3.11) that, for simplicity, we present below in its *projection* into a conventional nonunitary form

$$UU^\dagger \neq I, \quad UU^\dagger = \hat{I} = 1/T, \quad (4.5)$$

$$U[(p^2/m + e^2/r)\psi(r)]U^\dagger = \quad (4.6)$$

$$\begin{aligned} & [(Up^2U^\dagger)/m + (e^2/r)UU^\dagger](UU^\dagger)^{-1}[U\psi(r)U^\dagger] = \\ & [(1/m)\hat{p}T\hat{p}T + e^2/r]\hat{\psi}(r) = E'\hat{\psi}(r), \end{aligned}$$

where one should note the different eigenvalue E' from the value E of Eq. (4.4) (due to the general noncommutativity of the Hamiltonian and the isounit).

At this point, Santilli and Shillady introduce the following realization of the nonunitary transform, that is, of the *fundamental isounit of hadronic chemistry*, Eq. (4.7) of FHC,

$$\begin{aligned} UU^\dagger = \hat{I} = 1/T = \exp\left([\psi(r)/\hat{\psi}(r)] \int \psi_1^\dagger(r)\psi_2(r)d^3(r)\right) = \\ 1 + [\psi(r)/\hat{\psi}(r)] \int \psi_1^\dagger(r)\psi_2(r)d^3(r) + \dots, \quad (4.7) \end{aligned}$$

where ψ and $\hat{\psi}$ are the solutions of the unitary and nonunitary equations, and ψ_k , $k = 1, 2$, are the conventional quantum mechanical wavefunctions of the two electrons.

It is evident that, as desired, the above isounit represents interactions that are: nonlinear, because dependent in a nonlinear way in the wavefunctions; non-

local, because inclusive of a volume integral; and nonpotential, because not representable with a Hamiltonian. Additionally, for all mutual distances between the valence electrons greater than 1 fm, the volume integral of Eq. (4.7) is null with the crucial limit

$$\lim_{r>1\text{ fm}} \hat{I} = 1, \quad (4.8)$$

under which hadronic chemistry recovers quantum chemistry identically and uniquely. As it was the case for hadronic mechanics, hadronic chemistry merely provides a form of “completion” of quantum chemistry at short distances much along the celebrated intuition by Einstein, Podolsky and Rosen.

Santilli and Shillady solved the above equations in all details. First, by inserting isounit (4.7) in Eqs. (4.6), they obtained the isoequation here projected on a conventional Hilbert space

$$\left[\frac{p^2}{2m'} + \frac{e^2}{r} - V_o \frac{e^{-br}}{1 - e^{-br}} \right] \hat{\psi}(r) = E' \hat{\psi}(r), \quad (4.9)$$

where m' represents the isorenormalization of the mass caused by nonpotential interactions, and one recognizes the emergence of the *attractive Hulthen potential*

$$V_{\text{Hulthen}} = V_o \frac{e^{-br}}{1 - e^{-br}}. \quad (4.10)$$

But the Hulthen potential is known to behave like the Coulomb potential at short distances and be much stronger than the latter. Therefore, Eq. (4.9) admits the excellent approximation

$$\left[\frac{p^2}{2m'} - V' \frac{e^{-br}}{1 - e^{-br}} \right] \hat{\psi}(r) = E' \hat{\psi}(r), \quad (4.11)$$

where the new constants V' reflects the “absorption” of the repulsive Coulomb potential by the much stronger *attractive Hulthen potential*.

In this way, Santilli and Shillady achieved for the first time in the history of chemistry a valence coupling between two identical electrons in singlet coupling with a strongly attractive force, as requested by experimental evidence, which model is today known as the *Santilli-Shillady strong valence bond*.

4.2.C The isoelectronium (1999)

Another major insufficiency of quantum chemistry is the *lack of restriction of the valence correlation-bond specifically and solely to a valence pair*. This additional insufficiency causes further inconsistencies between the prediction of the theory and reality, such as the prediction that all molecules are paramagnetic, in dramatic disagreement with experimental evidence.

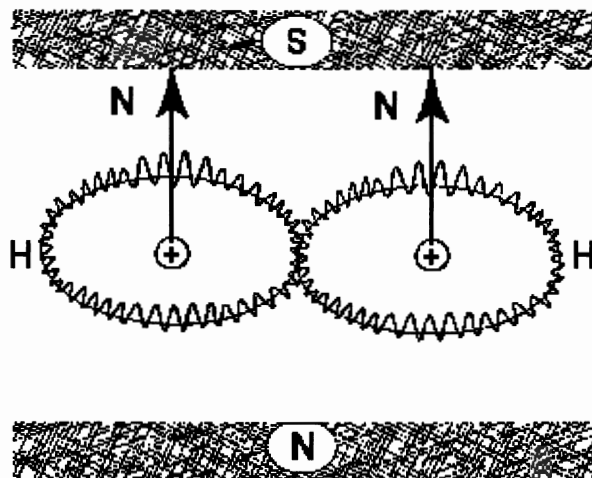

Figure 4.3. The original drawing used by Santilli to illustrate a catastrophic consequence of the quantum chemical notion of valence, the prediction of the paramagnetic character of all substances. The prediction includes the hydrogen molecule, in dramatic disagreement with experimental evidence according to which the hydrogen molecule is diamagnetic, thus being unable to acquire a total magnetic polarization under an external magnetic field. The indicated prediction is a consequence of the absence in quantum chemistry of a strongly attractive valence force, in which case valence electrons are unconstrained and, consequently, can acquire independent magnetic polarizations under an external magnetic field. The picture provides a conceptual rendering of the two H-atoms of the hydrogen molecule as essentially being independent. The alternative conception of orbitals distributed around the two nuclei carries an even stronger prediction of paramagnetic character because it can acquire more easily a total polarization under an external magnetic field contrary to nature.

Alternatively and equivalently, the fact that the hydrogen molecule is not paramagnetic can solely be represented via a strong bond between a valence electron pair into a quasiparticle Santilli and Shillady called the *isoelectronium*, that, as a necessary condition to avoid the prediction of the paramagnetic character of the H – H molecule, must have an oo-shapes orbit around the individual H atom as shown in Figure 4.4.

In the event the isoelectronium orbits along a single external orbit encompassing the two nuclei, its orientation under a sufficiently strong external field is consequential, resulting again in the catastrophic prediction of the paramagnetic character of the H – H molecule.

On technical grounds, the isoelectronium is the bound state of two identical valence electrons in singlet coupling characterized by the isoequation (4.9). Intriguingly, said equation admitted one and only one eigenvalue, thus characterizing the isoelectronium as a quasiparticle possessing the following main characteristics (see FHC for details):

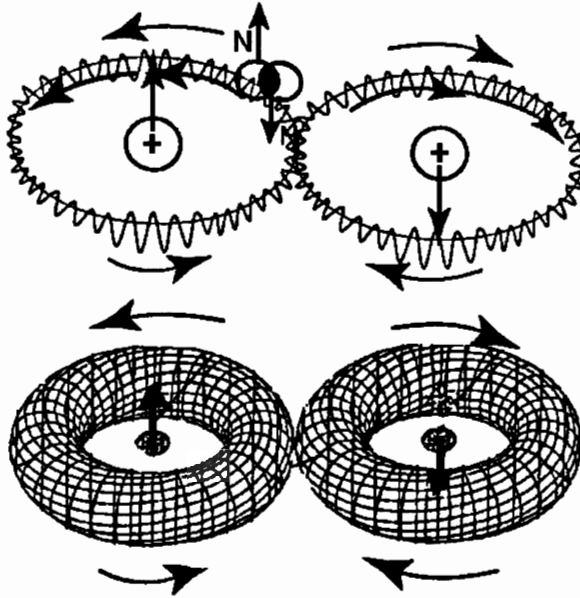

Figure 4.4. A view of isochemical model of the hydrogen molecule at absolute zero degrees temperature, thus without any rotational degree of freedom, with the Santilli-Shillady strong valence bond between valence electrons pairs into the isoelectronium quasiparticle. Note the o-shaped orbital of the isoelectronium, the only one allowing a representation of the diamagnetic character since, under an external strong magnetic field, the two H atoms acquire parallel but opposite magnetic polarities with null value at sufficient distance. Note also the toroidal distribution of the orbital of the isoelectronium due to the isouncertainty principle of hadronic mechanics.

ISOELECTRONIUM: Mass = 1.022 MeV; spin = 0; charge = $2e$; magnetic moment = 0; radius $b^{-1} = 6.8432 \times 10^{-11}$ cm.

Needless to say, the isoelectronium is *unstable* because the isouncertainty principle predicts the tunneling of the electrons through the nonpotential barrier. However, the bond between identical electrons in singlet coupling is so strong to cause the recombination of the isoelectronium following its spontaneous disintegration since the bond is attractive at distances much bigger than b^{-1} due to the extended character of the wavepackets.

It should be indicated that the name “isoelectronium” was proposed to emphasize the fact that *the individual electrons in valence couplings are not conventional particles, but isoelectrons*, that is, electrons under Hamiltonian and non-Hamiltonian interactions characterized by the fundamental Poincaré-Santilli isosymmetry, thus having not only conventional renormalizations of *kinematical* characteristics caused by Hamiltonian interactions, but also isorenormalizations of *intrinsic* characteristics caused by non-Hamiltonian interactions.

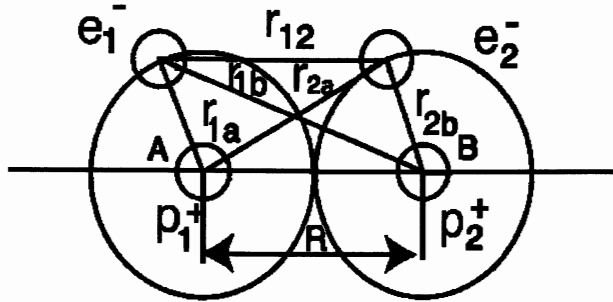

Figure 4.5. A view of all possible conventional interactions between the two electrons and the two protons of a hydrogen molecules. Being quantum mechanical, all these interactions are solely at a distance derivable from a potential, as in Eq. (4.12), thus being basically insufficient for a representation of the short term nonpotential interactions in valence bonds.

A fundamental feature is that *the strongly attractive Santilli-Shillady valence bond has no potential energy by central assumption because originating from nonpotential/non-Hamiltonian interactions.* By recalling that the mass of the electron is 0.511 MeV, the mass of the isoelectronium 1.022 MeV is therefore assumed under the assumption that the positive potential energy for the Coulomb repulsion cancels out with the negative binding energy of the electron magnetic fields that, in singlet coupling, is attractive.

4.2.D The hydrogen molecule (1999)

By combining the vast advances outlined until now, hadronic chemistry permitted the first achievement of an exact-numerical representation of all characteristics of the hydrogen molecule H₂ = H – H from unadulterated first principles without ad hoc adulterations, including binding energy, electric and magnetic moments, size, and other features, as presented in FHC Section 4.4 and historical paper [113].

As it is well known, according to quantum chemistry, the hydrogen molecule is a *four body* system comprising two protons and two electrons with conventional equation for the molecule at rest, that is, the two protons are considered as rest as conventionally done

$$\left[\frac{p_1^2}{2m_1} + \frac{p_2^2}{2m_2} + \frac{e^2}{r_{12}} - \frac{e^2}{r_{1a}} - \frac{e^2}{r_{1b}} - \frac{e^2}{r_{2a}} - \frac{e^2}{r_{2b}} + \frac{e^2}{R} \right] \psi(r) = E\psi(r), \quad (4.12)$$

where 1, 2 represents the two electrons; a, b represent the two protons; and R is the distance between the protons. Due to its four-body character, the above

equation, does not admit any analytic solution; misses at least 2% of the binding energy; and predicts that the hydrogen molecule is paramagnetic due to the evidence independence of the electrons.

The repetition of the nonunitary transform of the preceding section yield *the isochemical model of the hydrogen molecule as a four-body system*

$$\left[\frac{p_1^2}{2m'_1} + \frac{p_2^2}{2m'_2} - \widehat{V} \frac{e^{-br}}{1 - e^{-br}} + \frac{e^2}{R} \right] \widehat{\psi}(r) = E' \widehat{\psi}(r), \quad (4.13)$$

showing the appearance of the Santilli-Shillady strong valence bond of Hulthen type that “absorbs” all coulomb potentials, where m' represents the isorenormalized mass of the electrons.

In the figures below we provide the results of the solutions of the isochemical model (4.13) achieved via variational methods by Santilli and Shillady in their historical paper of 1999, with detailed elaboration additionally provided in FHC, Chapter 4.

However, a fundamental implication of hadronic chemistry is that of restricting the above four-body model to a *three-body structure* evidently composed by the two protons at mutual distance R and the two valence electrons strongly bonded into the isoelectronium quasiparticle. In fact, by repeating the nonunitarity map of the preceding section, *the isochemical model of the hydrogen molecule as a three-body system* can be written

$$\left[\frac{p_{\text{isoe}}^2}{2m_{\text{isoe}}} + \frac{p_a^2}{2m_{\text{prot}}} + \frac{p_b^2}{2m_{\text{prot}}} - \widehat{V} \frac{e^{-br}}{1 - e^{-br}} + \frac{e^2}{R} \right] \psi(r) = E' \psi(r), \quad (4.14)$$

where the system does admit an analytic solution in its restricted form under the assumption that the isoelectronium is stable; and one should note again the change of the eigenvalue in the transition from Eq. (4.12). Note also that Eq. (4.14) is purely quantum chemical because all distances between the constituents are much bigger than 1 fm.

An exact *variational* solution of model (4.14) was first studied in 2000 by A. K. Aringazin and M. G. Kucherenko in paper [183]. The exact *analytic* solution of model (4.14) was achieved in 2007 by R. Perez-Enriquez and R. Riera in paper [191].

4.2.E The water molecule (2000)

Despite a deceptive simplicity, the water molecule $\text{H}_2\text{O} = \text{H} - \text{O} - \text{H}$ is one of the most complex structures in nature whose understanding, let alone its representation, is beyond the capability of the rather limited theories of the 20th century because of the following additional insufficiencies or inconsistencies:

1) Quantum chemistry not only fails to achieve an exact representation of the binding energy of the water molecule from first principles without ad hoc

Table 4.1. Summary of results for the hydrogen molecule.

Species	H ₂	H ₂ ^a	H ₂
Basis screening			
1s	1.191	6.103	1.191
2s	0.50	24.35	0.50
2p	0.50	24.35	2.36
3s	0.34	16.23	*
3p	0.34	16.23	*
3d	0.34	-16.2 ^b	*
4sp	0.25	12.18	*
4f	0.25	12.18	*
Variational energy (a.u.)	*	-7.61509174	*
SCF energy (a.u.)	-1.12822497	*	-1.13291228
CI energy (a.u.)	-1.14231305	*	*
CINO energy (a.u.)	-1.14241312	*	*
SAS energy (a.u.)	*	*	-1.174444
Exact energy (a.u.) [30]	-1.174474	*	-1.174474
Bond length (bohr)	1.4011	0.2592	1.4011
Isoelectronium radius (bohr)	*	*	0.01124995

^aThree-body Hamiltonian (5.1).

^bThe negative 3d scaling indicates five equivalent three-sphere scaled to 16.20 rather than "canonical" 3d shapes.

Table 4.2. Isoelectronium results for selected molecules.

Species	H ₂	H ₂ O	HF
SCF-energy (DH) (a.u.)	-1.132800 ^a	-76.051524	-100.057186
Hartree-Fock ^d (a.u.)			-100.07185 ^d
Iso-energy (a.u.)	-1.174441 ^c	-76.398229 ^c	-100.459500 ^c
Horizon R _c (Å)	0.00671	0.00038	0.00030
QMC energy ^{d,e} (a.u.)	-1.17447	-76.430020 ^e	-100.44296 ^d
Exact non-rel. (a.u.)	-1.174474 ^f		-100.4595 ^d
Corellation (%)	99.9 ^b	91.6 ^b	103.8
SCF-dipole (D)	0.0	1.996828	1.946698
Iso-dipole (D)	0.0	1.847437	1.841378
Exp. dipole (D)	0.0	1.85 ^g	1.82 ^g
Time ^h (min:s)	0:15.49	10:08.31	6:28.48

(DH⁺) Dunning-Huzinaga (10S/6P), {6,2,1,1,1/4,1,1}+H₂P₁+3D1.

^aLEAO-6G1S + optimized GLO-2S and GLO-2P.

^bRelative to the basis set used here, not quite HF-limit.

^cIso-energy calibrated to give exact energy for HF.

^dHartree-Fock and QMC energies from Luchow and Anderson [33].

^eQMC energies from Hammond *et al.* [30].

^fFirst 7 sig. fig. from Kolos and Wolniewicz [34].

^gData from Chemical Rubber Handbook, 61st ed., p. E60.

^hRun times on an O2 Silicon Graphics workstation (100 MFLOPS max.).

Figure 4.6. A reproduction of Tables 4.1 and 4.2 of Santilli's FHC showing the achievement by isochemistry of a numerically exact representation of all features of the hydrogen molecule.

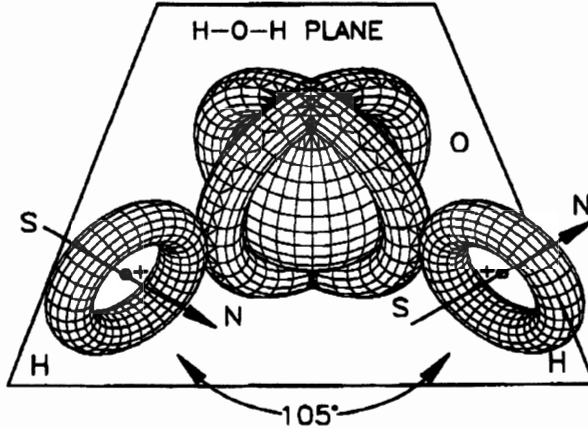

Figure 4.7. A view of the water molecule H_2O at absolute zero degree temperature, thus without any rotational degree of freedom, showing the $\text{H}-\text{O}-\text{H}$ plane, the 105° between the $\text{H}-\text{O}$ and $\text{O}-\text{H}$ dimers and, above all, the natural occurrence according to which the orbitals of the H atoms are not spherical, but of toroidal character for their coupling with the oxygen, thus providing a direct verification of the isochemical model of the hydrogen molecule of Figure 4.5.

adulterations, but predicts electric and magnetic polarizations that are wrong even in the sign, let alone in their (absolute) values.

2) Quantum chemistry is a structurally linear theory, thus representing complex multi-body systems such as the water molecule via the factorization of the total wavefunction into its individual components,

$$\psi_{\text{total}} = \psi_1 \psi_2 \dots \psi_n, \quad (4.15)$$

which factorization, in turn, requires the validity of the *superposition principle* as a pre-requisite for consistency. However, multi-body systems are nonlinear (in the wavefunction and other quantities), under which occurrence the superposition principle is inapplicable, with consequential impossibility of formulating a consistent factorization

$$H(r, p, \psi, \dots) \psi_{\text{total}} \neq H(r, p, \psi, \dots) \psi_1 \times \psi_2 \times \dots \psi_n, \quad (4.16)$$

thus resulting in the inapplicability of the very axioms of quantum chemistry to complex structures such as the water molecule.

3) When passing to the synthesis of the water molecule, the insufficiencies of quantum chemistry become embarrassing because the former process is structurally irreversible, while the latter theory is reversible, thus predicting with equal

statistical probability both the synthesis and its spontaneous decay (Section 1.9)



thus becoming inapplicable for a serious study.

4) When passing to water molecules as part of complex environments such as in the liquid state or when at the foundation of life, the insufficiencies of quantum chemistry become simply beyond any level of acceptability.

5) Besides all these limitations or sheer inconsistencies, quantum chemistry admits an additional rather crucial limitation given by the poor convergence of perturbative series. In essence, the water and other complex molecules are multi-body systems, thus requiring approximate solutions via variational, perturbative, Gaussian, and other methods, all based on expansions whose calculations require computers due to their complexity. The insufficiency here referred to is given by the fact that the time requested for basic calculations by large computers is generally excessive, thus implying an inherent lack of strong convergence of the underlying perturbative series, with consequential debatable accuracy.

All the above insufficiencies or sheer inconsistencies establish that the selection of the appropriate *generalization* of quantum chemistry should indeed be subjected to scientific debate, but its denial for the preservation of an old theory is equivocal and ascientific.

Santilli conceived and constructed hadronic mechanics and chemistry for the solution of the above insufficiencies. In fact:

1) Hadronic chemistry achieved the first exact representation of all features of the water molecule from first unadulterated principles;

2) The reconstruction of linearity on the Hilbert-Santilli isospace over Santilli isofields (isolinearity) achieved via the embedding of all nonlinear terms in the isounit and isotopic element,

$$H(r, p, \psi, \dots) = H_o(r, p)T(\psi, \dots), \quad (4.19)$$

and restores the superposition principle with exact factorization

$$H_o(r, p)T(\psi, \dots)\psi_{\text{total}} = H_oT(r, p, \psi, \dots)\psi_1 \times \psi_2 \times \dots \times \psi_n, \quad (4.20)$$

with consequential validity of the isotopic theory for complex systems.

3) The entire branch of *genochemistry* has been constructed by Santilli with an irreversible structure precisely to resolve the inconsistency 3).

4) The additional branch of *hyperchemistry* has been built by Santilli precisely to initiate the study of complex inorganic and organic structures, as we shall see later on this chapter (see Section 4.5 below).

5) Yet another central feature of isochemistry is that the absolute value of the isounit, such as Eq. (4.7), is much bigger than one and the isotopic element is

much smaller than one. Consequently, all series that are slowly convergent are turned into a strongly (fast) convergent form. In fact, the variational calculations for the isochemical model of the water molecule turned out to require a computer time at least 1,000 shorter than that of conventional calculations (see FHC for details).

The understanding of hadronic chemistry requires the knowledge that it permits a series of treatments of the water molecule with increasing complexities and methodological capabilities. The first treatment addressed in this section is that via isochemistry and applies when the water molecule is assumed as isolated from the rest of the universe, reversible over time and at absolute zero degrees temperature, thus without any rotational degrees of freedom as in Figure 4.7.

ISOCHEMICAL MODEL OF THE WATER MOLECULE: The model achieved for the first time the exact representation from first axiomatic principles without ad hoc adulterations of the binding energy, sign and values of the electric and magnetic moments, and other features as first presented by Santilli and Shillady in their second historical paper of 2000 [114] with a detailed presentation available in FHC, Chapter 5. The study is too complex for a technical outline in this section. Therefore, we limit ourselves to the following conceptual summary.

The model can be constructed and worked out via a series of progressively improving representations. The simplest one is given by achieving an exact solution for the dimer O – H and then introducing the additional H atom as a perturbation. This can be done by representing the oxygen as a two-body ion O⁻ characterized by one valence electron and all the rest of the atom assumed as concentrated in its nucleus with one single positive elementary charge.

The Santilli-Shillady strong bond of the valence electrons into the isoelectroonium then renders the system H – O⁻ a restricted three-body system with an exact solution. The additional H atom is then added as a perturbation or via other mean.

By denoting with the subindices 1 and *a* the hydrogen and 2 and *b* the oxygen, the conventional quantum chemical representation of the above indicated H – O⁻ dimer is similar to that of Eq. (4.12), i.e.,

$$\left[\frac{p_1^2}{2m_1} + \frac{p_2^2}{2m_2} + \frac{e^2}{r_{12}} - \frac{e^2}{r_{1a}} - \frac{e^2}{r_{1b}} - \frac{e^2}{r_{2a}} - \frac{e^2}{r_{2b}} + \frac{e^2}{R} \right] \psi(r) = E\psi(r). \quad (4.21)$$

Santilli and Shillady then apply a nonunitary transform as for the hydrogen molecule, resulting in the appearance of the strongly attractive Hulthen potential as in model (4.13). At this point, the bond of the second H atom can be represented via a nonunitary image of the Coulomb law resulting in screening of Gaussian type

$$2e^2/r \rightarrow 2e^2(1 \pm e^{-\alpha r})/r, \quad (4.22)$$

where the double value $2e$ originate from the duality of the bonds in $\text{H} - \text{O} - \text{H}$; α is a positive constant to be determined from the data; the sign “-” applies for an O-atom as seen from an H-electron; and the sign “+” applies for the O-atom as seen from the H-nucleus.

Note that lifting (4.22) would be aprioristic and without axiomatic foundation for quantum chemistry, since it requires a *nonunitary* image of the Coulomb law, while for the covering hadronic chemistry it is derived from first principles, namely, via precisely the needed nonunitary transform of quantum settings.

The implementation of the above features then yields the *isochemical model of the water molecule* in its projection in the conventional Hilbert space over conventional fields

$$\left[\frac{p_1^2}{2m'_1} + \frac{p_2^2}{2m'_2} - \widehat{V} \frac{e^{-br}}{1 - e^{-br}} - \frac{2e^2}{r_{2a}} - \frac{2e^2(1 - e^{-\alpha r_{1b}})}{r_{1b}} + \frac{e^2(1 + e^{-\alpha R})}{R} \right] \widehat{\psi}(r) = E' \widehat{\psi}(r), \quad (4.23)$$

where E' is half of the binding energy of the water molecule; R is the interatomic distance; and the size of the isoelectronium should also be fitted from the data.

Under the above approximation, plus the assumption that the isoelectronium is stable, model (4.23) constitutes the first exactly model of the water molecule from first principles in scientific history. Such an exact solution was first reached by Santilli and Shillady via variational methods in their historical paper of 2000, with comprehensive variational studies conducted by A. K. Aringazin a reproduced in Chapter 6 of FHC.

Note the *double* nonunitary transform requested by the model, the first for the isoelectronium and related strong bond, and the second for the representation of the second H atom via a perturbation-screening of the $\text{H} - \text{O}$ dimer. Note also that the model is invariant if and only if written on Hilbert-Santilli isospaces over Santilli isofields. Note finally that the computer usage needed for the variational calculations resulted to require 1/1000 shorter time than that needed for conventional model because both unitary transforms verify the conditions that the related isotopic element is must smaller than one.

A more accurate isochemical model of the water molecule is given by a *five body* system comprising the two H nuclei, the O atom assumed with all electrons concentrated in the nucleus except for the two valence electrons, and two isoelectronia assumed as fully stable. Needless to say, this model admits no analytic solution, thus requiring variational or other approaches.

A further isochemical model is the preceding one in which the two isoelectronia are assumed as being unstable and their meanlives are computed from the experimental data.

Table 5.1. Isoelectronium results for selected molecules [3b].

	OH ⁺	OH ⁻	H ₂ O	HF
SCF-Energy ^a	-74.860377	-75.396624	-76.058000	-100.060379
Hartree-Fock ^b				-100.07185 ^b
Iso-Energy ^c	-75.056678	-75.554299	-76.388340	-100.448029
Horizon R_c (Å)	0.00038	0.00038	0.00038	0.00030
QMC Energy ^{b,d}	-76.430020 ^d			-100.44296 ^b
Exact non-rel.				-100.4595
Iso-Dipole (D)	5.552581	8.638473	1.847437	1.8413778
Exper. Dipole			1.84	1.82

^a Dunning-Huzinaga (10s/6p), (6,2,1,1,1/4,1,1)+H2s1+H2p1+3d1.

^b Iso-Energy calibrated to give maximum correlation for HF.

^c Hartree-Fock and QMC energies from Luchow and Anderson [22].

^d QMC energies from Hammond, Lester and Reynolds [21].

Figure 4.8. A reproduction of Table 5-1 of Santilli's FHC summarizing the achievement of the first numerically exact representation of the binding energy, electric and magnetic moments of the water molecule.

GENOCHEMICAL MODEL OF THE WATER MOLECULE. It is based on the assumption of *two* nonunitary transforms for the characterization of the forward "F" and backward "b" genounits and related motion in time

$$UW^\dagger = I^f, \quad WU^\dagger = {}^bI, \quad (4.24)$$

$$I^f = ({}^bI)^\dagger, \quad (4.25)$$

The model is particularly useful for the *irreversible representation of the synthesis of the water molecule* $H_2 + O \rightarrow H_2O$ in such a way to prevent the existence of a finite probability for the spontaneous time reversal image.

HYPERCHEMICAL MODEL OF THE WATER MOLECULE. It is essentially given by a multi-valued extension of the preceding models and has resulted as having basic relevance for the initiation of the understanding of the complexity of the water molecule when part of living cell, thanks also to the availability of a virtually unlimited degree of freedom for biological correlations and other complex events (see Section 4.5 below). Note that the water molecule acquires such a complexity as being beyond our conceptual understanding.

ISODUAL ISO-, GENO-, AND HYPER-CHEMICAL MODELS OF THE WATER MOLECULE. They are the images of the preceding models characterized by the isodual map (2.9) and are used for quantitative studies of the *antimatter water molecule* (see FHC for details).

Additional very important studies on hadronic chemistry were conducted by A. K. Aringazin and his group in Kazakhstan. Besides the detailed review of these studies by Santilli in FHC, we indicate here additional papers [184, 185].

4.3 The New Chemical Species of Santilli Magnecules

4.3.A Historical notes

The dimension of Santilli's scientific conceptions can be understood by noting that all the preceding advances on *conventional* molecular structures were done as a mere *preparatory basis* for the conception, quantitative treatment, experimental verification and industrial development of a basically *new* chemical species, that is, a species whose bond is NOT that of valence. The results were presented in yet another historical paper of 1998 [108] with a detailed presentation in FHC and an update in the monograph of 2008 [25], plus various papers quoted in the subsequent sections.

4.3.B Conception of Santilli magnecules (1998)

The primary origin of pollutants contained in fossil fuel exhaust is the valence bond that is so strong to prevent full combustion. Consequently, Santilli set his research goal to search for a new way of bonding together into stable clusters the same atoms composing fossil fuels under the following:

CONDITION 1: The new bond should be *weaker* than the valence bond as a necessary condition to decrease pollutants;

CONDITION 2: The new weaker bond should allow the formation of clusters that are *stable* at industrially used storage values of temperature and pressure, e.g., those for methane; and

CONDITION 3: The new, weaker and stable bond should *decompose* itself at the combustion temperature to optimize the energy released by the combustion.

As we shall see later, the above conditions permitted the identification of new environmental processes in which pollutants in the exhaust are decreased by increasing the combustion. In particular, fuels verifying the above conditions are said to admit a *full combustion*, namely, they release no uncombusted component in the exhaust, that is, no HydroCarbons HC, carbon Monoxide CO and other combustible contaminants present in fossil fuel exhaust.

By proceeding in his typical analytic way, following the identification of his research goal, Santilli conducted systematic studies on the realization of the above conditions. To understand the difficulties facing the conception and production of a new chemical species, one should recall that atoms have a spherical distribution of their orbitals, thus normally exhibiting the sole possibility of a valence bond. Hence, *Santilli had to create a new force field in atoms* as a condition to achieve a new chemical species.

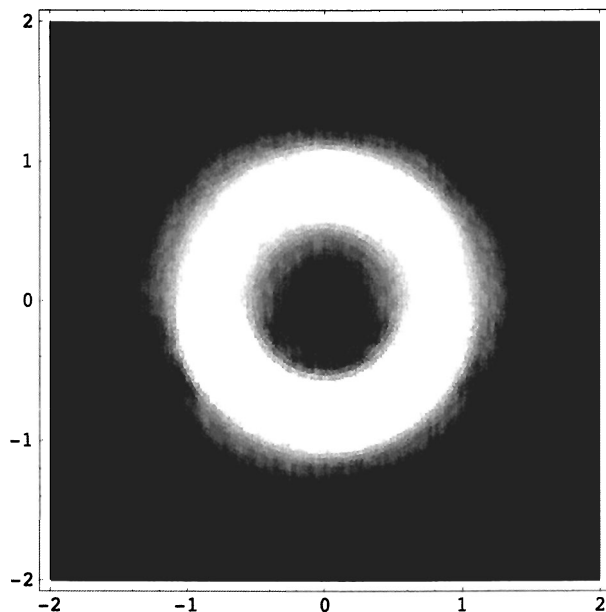

Figure 4.9. The new chemical species of Santilli magnecules requires an atomic technology capable of polarizing the orbitals of individual atoms (rather than molecules) into a toroidal form (rendering by A. K. Aringazin).

The answer originated from Condition 3 that suggested the use of *magnetic forces* since all magnetic effect disappears at a given temperature (called the Curie Temperature). Therefore, Santilli argued that, in the event a new bond could be based on magnetic fields, all Conditions 1, 2, 3 would be verified because: magnetic bonds are known to be weaker than valence bonds; they are expected to be stable under ambient conditions; and they are expected to decompose themselves at the combustion temperature that was assumed as being the Curie temperature of the new bond.

Santilli argued that the possible control of the distribution of atomic orbitals, from their conventional spherical form to a *toroidal form* would indeed create a magnetic dipole North-South along the symmetry axis, thus creating the needed new field in atoms that normally have none.

A huge difficulty then emerged because it is known in the technical literature that the control of the orbitals of atomic electrons requires extremely strong magnetic fields of the order of 10^{10} Gauss or more, namely, magnetic fields at least 1,000 times stronger than the biggest magnetic field available at the U. S. Large Magnet Laboratory in Tallahassee, Florida.

By again proceeding in his analytic way, Santilli conducted a systematic search of engineering means for exposing atomic orbitals to the needed very strong mag-

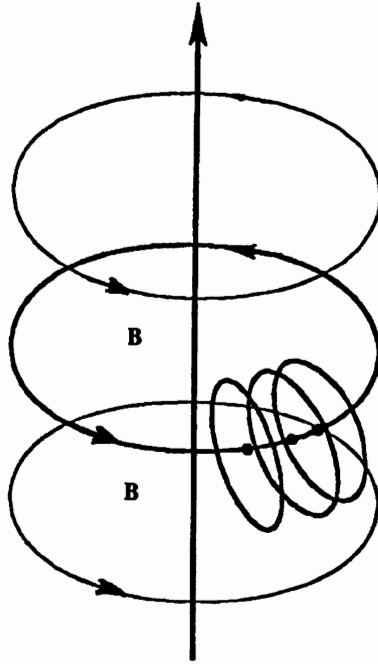

Figure 4.10. The sole known possibility of industrial production of new fuels with Santilli magnecular structure is given by submerged electric arcs due to the need for very strong magnetic fields that are indeed provided by electric arcs at atomic distances. In particular, the arc performs three important functions: 1) the polarization of atomic orbitals into toroids with symmetry axis tangent to the local magnetic force given by a circle perpendicular to the arc direction; 2) The coupling of different atoms with opposing magnetic polarities North-South-North-South-etc.; and 3) The compression of magnetically polarized and coupled atoms toward the arc due to still unknown effects.

netic fields, and concluded his studies with the selection of DC *electric arcs* submerged within a fluid (a gas or a liquid). In fact, in this case, the magnetic field M follows the known law

$$M = kA/r, \quad (4.26)$$

where A represents the number of Amperes of the arc, r the distance from the arc and k a constant depending of the selected units whose value is here irrelevant. Therefore, at atomic distances from the arc, that are of the order of 10^{-8} cm, and for currents of the order of 10^3 A, the magnetic field M is indeed of the desired order of 10^{11} Gauss.

In early 1998, Santilli introduced his new chemical species he called *magnecules* to distinguish them from conventional *molecules*, the former having the new *mag-*

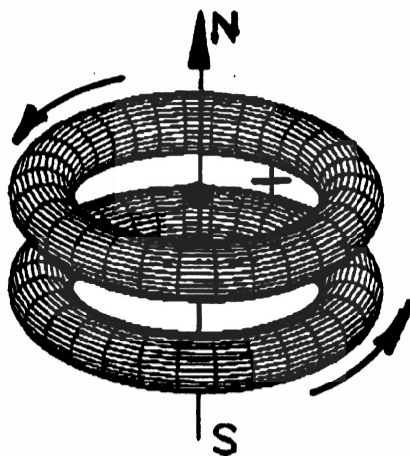

Figure 4.11. A conceptual rendering of an “elementary magneccule” comprising two identical or different atoms whose bond is entirely of magnecular character, namely, originating from opposing polarities North-South-North-South of the toroidal distributions of orbitals, as well as the polarization of nuclear and electron magnetic moments.

necular bond, the latter being characterized by the conventional *valence* bond, the new species being defined as follows:

SANTILLI MAGNECCULES: Are given by clusters comprising individual atoms, such as H, C, O, etc., dimers, such as H–O, C–H, etc., and ordinary molecules, such as C–O, CO₂, etc., bonded together by opposing magnetic polarities of toroidal polarizations of atomic orbitals plus opposing nuclear and electron magnetic polarizations. Electric polarizations are evidently expected to participate in the magnecular bond, although they are notoriously weaker and much more unstable than magnetic bonds.

In the historical paper of 1998 Santilli conducted a quantitative identification of the magnetic field caused by electrons rotating at a speed close to the speed of light within a toroidal polarization, and concluded that such a magnetic field is about 1,315 stronger than the nuclear magnetic field. This calculation was independently verified for the first time by M. G. Kucherenko and A. K. Aringazin in paper [181]. Additional comprehensive studies were conducted by A. K. Aringazin, as in paper [198].

4.3.C Detection of Santilli magneccules

There should be no surprise on the fact that no new chemical species were discovered from the pioneering studies by Avogadro, Canizzaro and others of the

Information from Data File:
 File : C:\HPCHEM\1\DATA\0618004.D
 Operator : NAW
 Acquired : 18 Jun 98 3:01 pm using AcqMethod VOC_IRMS
 Sample Name: TOUP'S TECH
 Misc Info : 1ML LOOP; 10C @ ULTRA COLUMN
 Vial Number: 1
 CurrentMeth: C:\HPCHEM\1\METHODS\DEFAULT.M

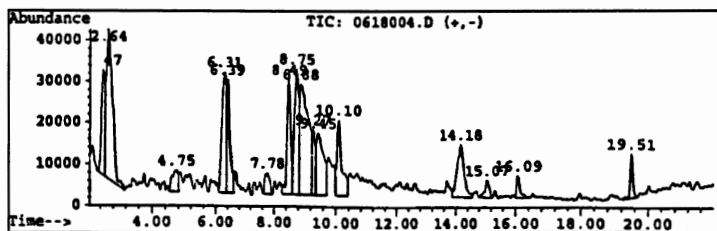

Retention Time	Area	Area %	Ratio %
Total Ion Chromatogram			
2.474	1753306	5.386	32.724
2.644	5091514	15.641	95.030
4.754	641528	1.971	11.974
6.307	2737749	8.411	51.098
6.390	2211258	6.793	41.272
7.782	592472	1.820	11.058
8.490	2357396	7.242	43.999
8.754	2784829	8.555	51.977
8.882	5357812	16.460	100.000
9.265	1123809	3.452	20.975
9.448	2421234	7.438	45.191
10.098	1946292	5.979	36.326
14.177	2129791	6.543	39.751
15.073	435208	1.337	8.123
16.085	389822	1.198	7.276
19.509	577433	1.774	10.777

Figure 4.12. The historical printouts on the original detection of Santilli magnequles achieved on June 19, 1998, at the analytic laboratories of McClellan Air Force Basis near Sacramento, CA, via a HP GC model 5890, and a HP MS model 5972 equipped with a HP IRD model 5965. The test was conducted on a gas with magnequcl structure produced by Santilli via an electric arc between graphite electrodes submerged within distilled water. According to quantum chemistry, the heaviest expected species was CO_2 at 44 amu. For this reason, the analysts set the scan between 40 amu and 400 amu, the latter being the instrument upper limit. At the appearance of the numerous unexpected species of the top figure, all much heavier than 44 amu and in macroscopic percentages, the analysts showed surprise.

middle of the 19th century until Santilli studies at the end of the 20th century. In fact, all available analytic methods and equipment have been conceived, developed and established for the detection of *molecules*, and NOT for magnequcles. Any belief that Santilli's magnequcles can be detected or denied via the use of conventional molecular means constitutes a mere illusion at best, the results emerging from such biased approaches being called by Santilli "experimental beliefs."

The serious scientist should remember that, by conception and construction, magnecules have a bond much *weaker* than that of molecules. Consequently, all analytic methods that are indeed very fast and efficient for the detection of molecules, usually destroy the very magnecular species to be detected, e.g., because the energy of ionization beams is much bigger than that for magnecular separation while being unable to cause any molecular separation. Also, all magnetic bonds and effects are known to have a Curie temperature at which they disappear. Therefore, any claim of lack of existence of magnecules via Gas Chromatographers (GC) and other equipment using thermal and/or high temperature detection processes, is purely nonscientific, since the thermal process destroys the very species to be detected.

By far the biggest difficulties were experienced by Santilli in the experimental verification of his new species, not only because of the deplorable conditions of analytic chemistry at the end of the 20th century for which no basic novelty was believed as being possible. Hence, when faced with anomalous results, rather than admitting possible novelty, analysts would enter into incredible gyrations and manipulations of the equipment for the specific intent of eliminating any possible novelty, and then claiming lack thereof.

A typical example in gas chromatography is the reduction of a peak in the mass spectrum, let us say, at 250 atomic mass units (amu) to its components H₂, CO, etc., and then claim absence of a new species, when the detected conventional molecules are the *constituents* of the peak at much lower amu, thus resulting in a pure "experimental belief" without scientific content.

Additional difficulties were created by the widespread practice of conducting only *one* detection and then claiming a final "experimental result," while in reality no result can be claimed to be scientific on serious grounds without at least a *second* verification with a *different* instrument. This practice is particularly insidious for magnecules because "experimental beliefs" obtained with one analytic equipment can be solely dismissed with a second independent verification.

Following a systematic study of all available equipment, Santilli selected the use of a Gas Chromatographer Mass Spectrometer equipped with an InfraRed Detector (GC-MS/IRD) because that instrument allows the study of the *same* cluster, firstly, in the mass spectrum and, secondly, under the IRD. In the event the GC-MS and the IRD are used separately, the MS peak would not generally appear in the IRD when of magnecular nature, thus leading to manipulations of experimental data and illusions of scientific process.

Santilli then conducted a nation wide search for a GC-MS/IRD to discover that no academic or commercial analytic laboratory in the U.S.A. had none since GC or GC-MS alone are very effective for molecular detections, thus leading to the widespread tendency of avoiding any verification of the results via a different equipment. Continued search revealed that military and forensic laboratories do

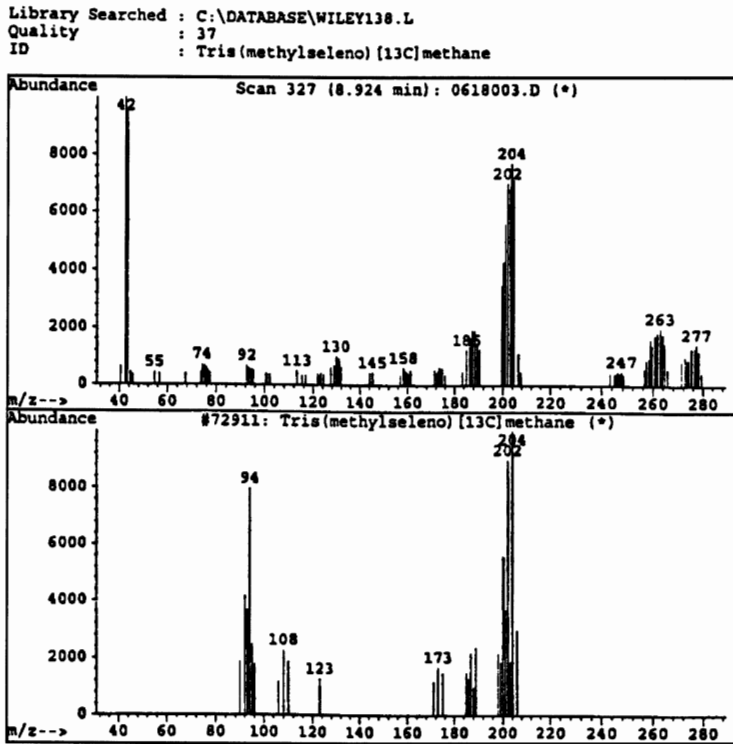

Figure 4.13. Following the identification of the unexpected peaks in the mass spectrum of the preceding figure, the analysts requested the computers of the Air Force Basis (containing in excess of 500,000 molecules) to identify the individual peaks. Contrary to expectation, the computer failed to produce the identification of any of the peaks of the preceding scan. Hence, the analysts indicated to Santilli that he had apparently produced "new yet unknown molecules."

generally have GC-MS/IRD due to stringier requirements for verification and accuracy.

Following such an extensive search, Santilli finally located the availability at the McClellan Air Force Base near Sacramento, California, of a GC-MS/IRD consisting of a HP GC model 5890, a HP MS model 5972, equipped with a HP IRD model 5965. Santilli visited said basis on June 19, 1998, with samples of gas produced via an arc between graphite electrodes submerged within distilled water. Following confirmation of the needed equipment, the GC-MS/IRD had to be used in way rather unusual for molecular tests, such as:

- 1) The feeding line had to be the largest available because feeding lines with small sectional area (of a fraction of 1 mm^2), that work perfectly well for molecular species, do not allow the passage of magnecular species with large amu due to an anomalous adhesion of magnecules to the internal walls of the feeding line;

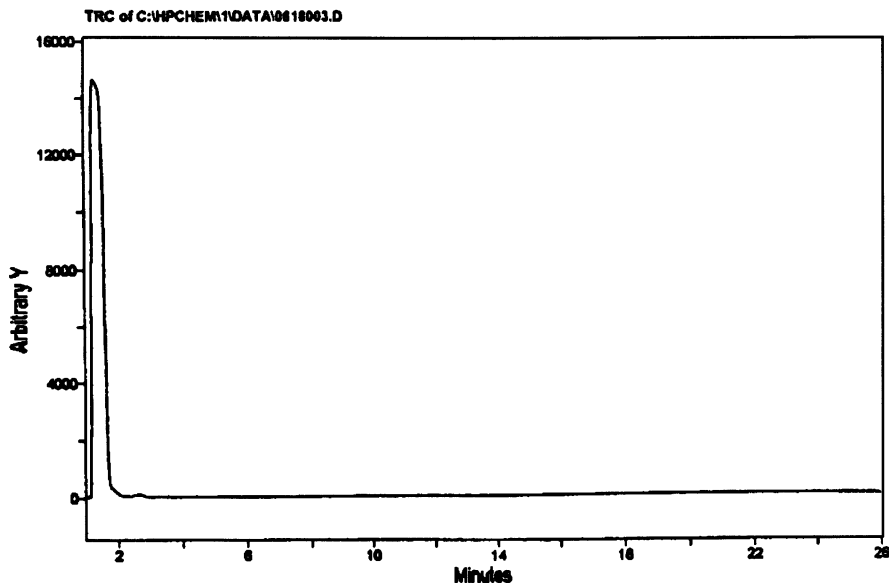

Figure 4.14. Following the failure by the computer to identify any of the detected peaks, Santilli requested the analysts to inspect the same peaks under the IRD. The above figure established that none of the peaks in the mass spectrum between 40 amu and 400 amu had any IR signature at all, thus establishing the the bond of the peaks cannot possibly be of valence type, since the sole molecule that shows no IR signature is the hydrogen and a few others light with orbitals having perfect spherical symmetry. The appearance in the computer screen of the IR scan of this figure has potentially historical meaning because it constitutes clear experimental evidence of the novelty of the bond. In fact, the analysts showed great surprise at the view of this scan and indicated to Santilli that he had indeed discovered a “new chemical species” which could not be that characterized by valence bonds. The analysts of the McClellan Air Force Basis then released a signed statement of novelty reproduced in the historical 1998 paper as well as in FHC.

2) The temperature of the column had to be the lowest possible because high column temperature, while excellent for rapid detection of molecules, destroy in part or in full the magneuclear species to be detected;

3) The elution time had to be the longest admitted by the instrument (and set at 21 minutes) to allow the proper separation of magnecules into clusters appearing in the mass spectrum, while short elution times so effective for the separation of molecules, may provide the superposition of magneuclear clusters without proper separation, thus with ambiguous results.

Following considerable perplexities due to the unusual character of the requests, the analysts at the McClellan Air Force Base did implement all unusual requests by Santilli and, in so doing, produced on June 19, 1998 the first experimental evidence on the existence of the new chemical species of magnecules reported in the figures below.

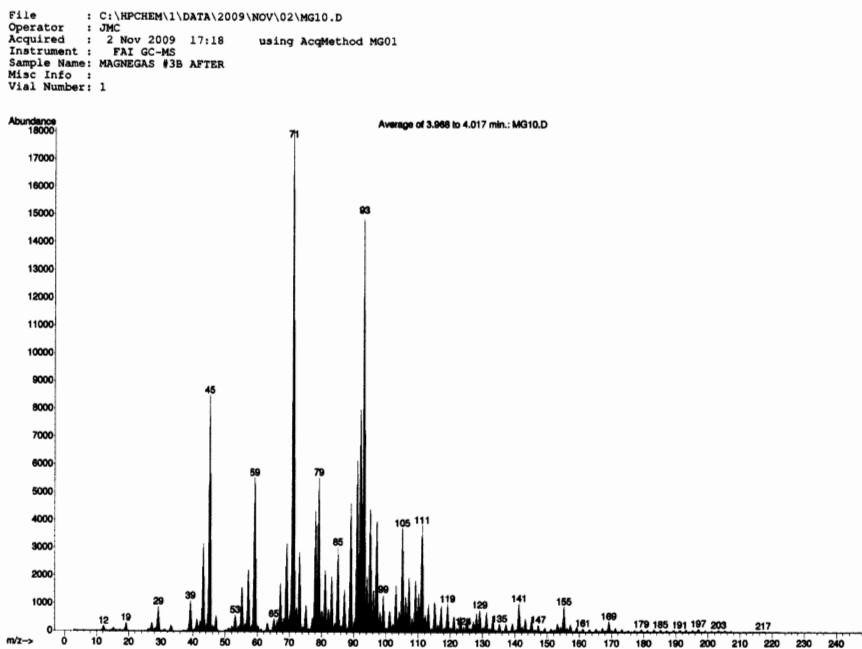

Figure 4.15. Following the original scans of 1978 reproduced in the preceding figures, numerous chemical analyses have been conducted on Santilli magnecules in three continents. We reproduce in this figure the MS spectrum of magnegas from 3 amu to 250 amu obtained by the FAI Laboratories in Atlanta Georgia, in April 2010. As one can see, the scan does not show the expected large peak at 28 amu that is routinely detected in the same gas via GC in the 35% range, and shows instead a series of anomalous peaks in full confirmation of the scan of Figure 4.12.

An additional experimental evidence is given by the *anomalous adhesion* of gases with a magnecular structure, namely, their adhesion to solid or liquid substances irrespective of whether paramagnetic or diamagnetic. This anomalous characteristic is established by the blanks of GC-MS that, following the flushing of the magnecular gas with an inert gas, show essentially the same peaks as those of the scan with the gas, to such an extent to require flushing with an inert gas at high temperature to recover conventional blanks, namely, those with no appreciable peaks except for background (see Figure 4.28 below). This feature evidently confirms the magnetic polarization of the gases here considered as well as its existence at the level of individual atoms, a condition necessary for adhesion via polarization by induction to both paramagnetic and diamagnetic substances. The feature also has a number of important industrial applications, such as the

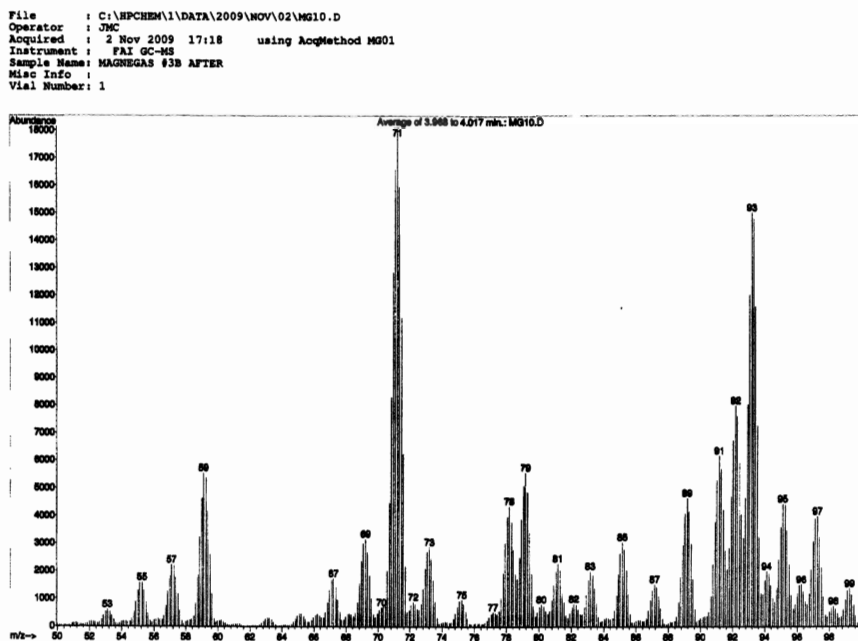

Figure 4.16. A more detailed view between 50 to 100 amu of the preceding FAI scan.

elimination of the seepage through containers walls for hydrogen when treated to have a magnecular structure (see Section 4.4E).

For additional experimental verification, we refer the serious scholar to the literature in the field, such as [18, 24, 118]. Figures 28, 29 of the latter reference present the scan of a GC-MS/IRD similar to that at the McClellan Air Force Bases, operated by a forensic laboratory in Largo, Florida with similar results (unknown heavy peaks in the MS without IR signature), although with the accumulation of the MS peaks due to the short elution time.

4.3.D Magnecular structure of H_3 and O_3 (1998)

As it is well known, GC-MS routinely detect the species H_3 at 3 amu and O_3 at 48 amu. Their interpretation in quantum chemistry is that via a conventional *valence bond*.

Santilli never accepted such an interpretation for various reasons. To begin, the deep correlation-bond of valence electrons is in single couplings as in Figure 4.2, thus creating a *boson* with total spin 0. Consequently, Santilli argues that *it*

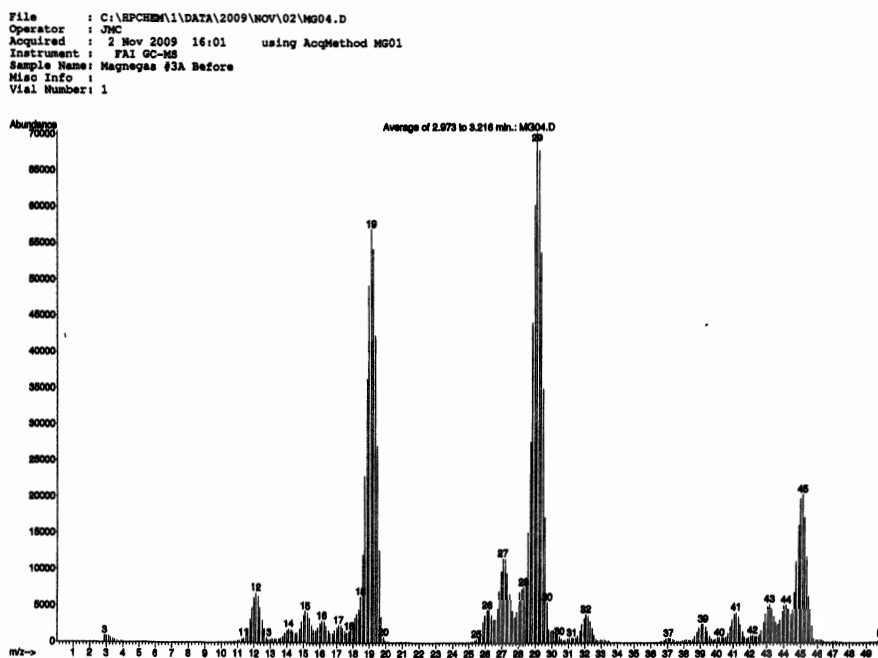

Figure 4.17. An additional illustration of the novelty of Santilli magneucle between 3 and 50 amu showing a peak at 19 amu now interpreted as $H_3O = H - O - H \times H$, another new peak at 29 amu interpreted as $C - O \times H$, and other peaks that can only be interpreted as being Santilli magneucle.

is impossible for quantum mechanics and chemistry that a fermion with spin 1/2, the electron, can bond to a boson with spin 0, the isoelectronium valence pair.

As recalled in Section 4.1, the notion of valence in quantum chemistry is not quantitative for various insufficiencies, including the absence of the correlation-bond of the valence electrons, specifically, to electron *pairs*. It is then evident that, in the absence of such a restriction, the species H_3 and O_3 can have a valence bond. However, such an interpretation is faced with serious inconsistencies, such as the prediction that all substances are paramagnetic (Section 4.2C).

Additionally, nature establishes beyond doubt that the valence bond is for electron pairs. Hence, the valence bond for the species H_3 and O_3 requires that only two out of three atoms are bonded at any given time. Santilli has proved that such an interpretation is disproved by the binding energies of H_3 and O_3 , namely, the predicted binding energy is in dramatic disagreement with experimental values.

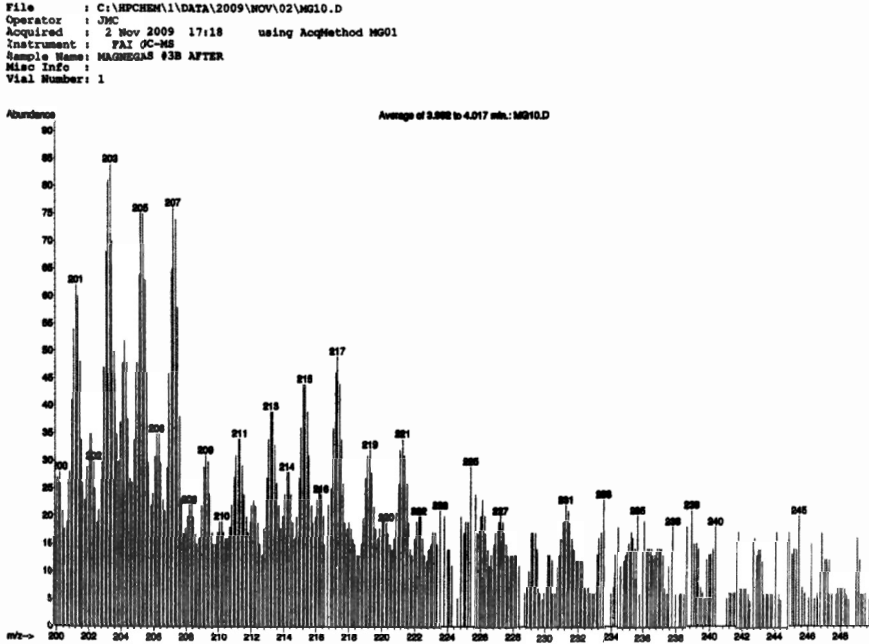
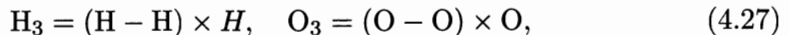

Figure 4.18. Yet another novelty of Santilli magneucle, the so called “accretion” of peaks by one amu that, evidently, can only be interpreted as the addition of one hydrogen atom, a new feature here illustrated from 200 to 250 amu, but which actually exist from 0 to 1,000 amu.

In view of the above and other evidence, Santilli proposed in FHC that the species H_3 and O_3 have a *magneclar structure* of the type



namely, they comprise ordinary molecules H_2 and O_2 with valence bond plus a third atom with magneclar bond (see Figure 4.20), thus being magneclules according to their definition. In any case, it is known that *ozone* O_3 is formed under electric discharges precisely as needed for the production of magneclules (Section 4.3B), and a similar mechanism holds for the H_3 .

4.3.E *Magneclar structure of liquids and solids (1998)*

Another notion of quantum chemistry rejected by Santilli since his graduate studies is the interpretation of the water liquid state as being due to “H-bridges” or similar conjectures, because, as it is the case for the valence, the notion is a pure nomenclature without the explicit identification of a force binding the water

SPECTRA REPORT | INTERNAL VAPOR ANALYSIS

Page 1of1
 ORS LOT NO 184443-001
 DATE TESTED 1/18/2010
 QUANTITY TESTED 2
 PACKAGE TYPE CYLINDER
 MFG CODE Date filled: 01/14/10
 Filled by: R.S.
 PO: XXXX-XXXX-XXXX-7641
 Rel. No:
 RUGGERO SANTILLO
 INSTITUTE FOR BASIC RESEARCH

720 WESLEY AVE
 SUITE #1
 TARPON SPRINGS, FL 34689
 UNITED STATES

SAMPLE ID	HT1	HT2	Mass	33	54	800
Mass 2	36,749	72,242	Mass 33	54	800	
Mass 3	9,638	223,826	Mass 34	463	2,573	
Mass 4	2,917,650	4,757,170	Mass 35	0	396	
Mass 5	0	1,258	Mass 36	0	3,290	
Mass 6	5,057	14,612	Mass 37	0	85	
Mass 7	0	98	Mass 38	0	100	
Mass 12	71	10,412	Mass 39	185	205	
Mass 13	0	477	Mass 40	3,844	6,961	
Mass 14	36,891	70,451	Mass 41	132	403	
Mass 15	227	911	Mass 42	70	463	
Mass 16	11,953	15,409	Mass 43	129	446	
Mass 17	749	17,310	Mass 44	472	6,646	
Mass 18	2,554	114,079	Mass 45	0	108	
Mass 19	878	15,911	Mass 46	0	148	
Mass 20	2,766	59,218	Mass 50	121	94	
Mass 21	0	628	Mass 51	123	85	
Mass 22	0	109	Mass 52	101	249	
Mass 24	0	616	Mass 53	0	75	
Mass 25	0	104	Mass 54	0	173	
Mass 26	166	4,603	Mass 55	0	219	
Mass 27	169	11,343	Mass 56	0	260	
Mass 28	304,901	629,602	Mass 57	0	294	
Mass 29	2,304	6,452	Mass 69	0	85	
Mass 30	3,587	20,538	Mass 71	0	103	
Mass 31	0	2,188	Mass 77	88	0	
Mass 32	79,062	31,752	Mass 78	374	138	
			Mass 82	0	147	
			Mass 83	0	133	
			Mass 84	0	630	
			Mass 85	0	77	
			Mass 91	117	0	

Figure 4.19. Yet another independent confirmation of Santilli magnecules, this time given by the dramatic increase of species for a deuterium gas (second column from the left) when traversed by a DC arc between carbon electrodes (last column to the right). The importance of the above scan is that of dismissing the widespread interpretation of new species as being “fragments” of larger molecules, for the evident intent of bypassing novelty. In fact, such a belief is dismissed by the fact that electric arcs separate molecules and create none. Therefore, the large increase of chemical species of this scan can only be interpreted via Santilli magnecules.

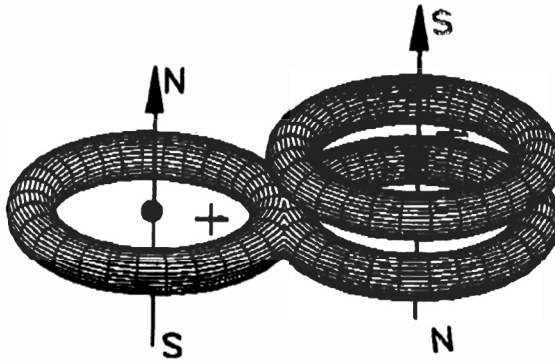

Figure 4.20. Quantum chemistry suggests that the valence, in one of its various nomenclatures without quantitative treatments, is responsible for all possible species existing in the universe, expectedly, until the end of time. Consequently, for quantum chemistry the species H_3 and O_3 are characterized by valence bonds. Santilli has identified numerous inconsistencies of such an interpretation and shown that said species have instead a magnecular structure comprising conventional molecules H_2 and O_2 with a third atom under magnecular bond as shown in the figure. In fact, ozone O_3 is formed under intense electric discharges that separate O_2 molecule as a condition to have a free oxygen atom, jointly polarize the O_2 molecule, and align them as in Figure 4.10, thus providing a natural representation of its formation, let alone of its structure in a way compatible with experimental data. The same holds for H_3 .

molecules together, without the proof that such a force is indeed attractive, and without showing that such an attractive force represents experimental data.

In his historical monograph FHC, Santilli proposed that *the liquid state of water as well as of other liquids has a magnecular structure*, namely, the bond between the water molecules is of dominant magnetic character, evidently with an inevitable component originating from electric polarizations. The view was based on various reasons, such as:

1) An inspection of the water molecule in its natural state as depicted in Figure 4.7, reveals that the orbitals of the H atoms do not have a spherical distribution, but instead have a toroidal one, thus possessing a natural magnetic field North-South along the symmetry axis. The same must occur for the orbitals of the corresponding valence electron of the O atom much along the Santilli-Shillady strong valence bond of Figure 4.5. It is then quite natural to interpret the bond between water molecules in the liquid state as caused by attractive, opposite, magnetic polarities North-South-North-South of the toroidal polarizations of the H and O orbitals, as in Figure 4.21.

2) All available valence electrons in the water molecule are strongly bonded, as established by the high value of energy needed for molecular separation. Consequently, any belief that the liquid state might originate from valence bonds is

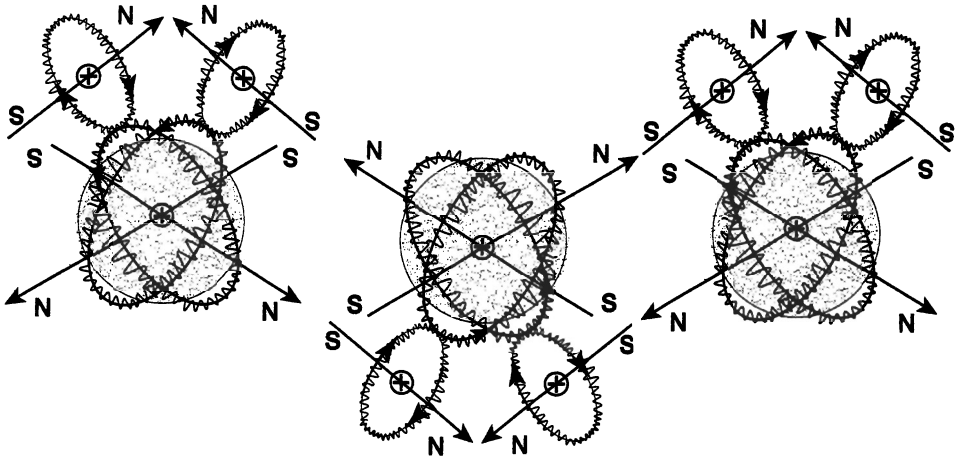

Figure 4.21. A schematic view of the magnecular structure of the liquid state of water discovered by Santilli and presented in FHC. The magnecular structure can be confirmed via a mere inspection of the presence of magnetic fields in the natural state of the water molecule as in Figure 4.7, whose coupling via opposing polarities North-South-North-South results precisely in the magnecular structure of this figure.

purely nonscientific. The water molecule is also neutral and, consequently, the sole use of electric polarizations as the entire origin of the bond for the water state fails to provide any quantitative representation of experimental data, such as the energy needed for the breaking of the liquid state into a gaseous form. These occurrences leave magnetic polarizations as the sole possible or otherwise plausible origin of the bond in the liquid state.

3) The breaking of the liquid state at the boiling temperature is a confirmation of its magnecular character, since all magnetic bonds cease to exist at a given temperature. As a matter of fact, the boiling temperature of water, 100°C, is the Curie temperature of the magnecular structure of liquid water.

In FHC Santilli provides experimental evidence obtained via Liquid Chromatographers Mass Spectrometers equipped with Ultra Violet Detectors (LC-MS/UVD, the equivalent for liquids of the GC-MS/IRD for gases) of the formation of various *liquid magnecules* via the use of magnetic fields, including a bond between oil and water. We regret to be unable to reproduce here this vast experimental evidence.

In FHC Santilli also presents evidence of *solid magnecules*, such as fullerenes, consisting of hard carbon composites that sublime at a sufficient high temperature, thus confirming the magnecular (rather than the valence) character of the bond. Additional examples of solid magnecules are given by certain calcium composites initiating with accretion, then bonding under pressure via magnetic

induction, and finally resulting in the formation of a solid. Additional examples of gaseous liquid and solid magnecules are nowadays identified rather frequently.

In Table 8.31, page 371 of FHC, Santilli presents experimental measurements conducted by the SGS Testing Laboratory of Fairfield, NJ, according to which liquids and solids exposed to intense magnetic field exhibit an *increase of their density*. This important feature is currently under industrial development for the production, e.g., of carbon composites with increased specific weight that are of great importance for automotive and other applications.

4.4 Industrial Realization of Fuels with Magnecular Structure

4.4.A Catastrophic forecasts facing mankind

As it is well known, mankind is nowadays extremely dependent on petroleum fuels, with about one billion cars, five millions trucks, five hundred thousand planes in daily use, plus an unknown number of military, industrial and agricultural vehicles, with clear trends for rapid increase of fuel consumption.

As it is equally well known, world petroleum reserves and production either have already reached their peak, or their maximal capacity is only a question of a few years, with catastrophic risks for mankind due to the expected exponentially increasing costs under shortages of petroleum fuels, to such a level to cause disruptions of the very fabric of our societies, all the way to nuclear wars.

Only totally irresponsible people can sit and wait for these disasters to occur and do nothing, since NOW is the time to initiate corrective measures. Along these lines, the only possible, or otherwise credible way to prevent said catastrophes is to develop an alternative fuel that, as Santilli puts it, to be really effective, must verify the following::

CONDITION I: The alternative fuel must be suitable for use in existing engines without structural modifications, as a prerequisite to really have a serious control of our future. For instance, fuel cells operated car, while fully commendable, cannot provide a real solution because they cannot replace one billion existing cars prior to the indicated catastrophes. Similarly, hydrogen as a fuel for internal combustion engines, even though equally warranted for development, is not a solution because its use requires a structural change of existing engines, and similar occurrences hold for other alternative fuels.

CONDITION II: The alternative fuel must be produced from a widely available feedstock other than petroleum or food. This condition eliminates ethanol produced from corn and similar alternative fuels as viable alternatives. In any case, a large scale production of a fuel from food would cause per se catastrophic problems in food shortage, price, etc.

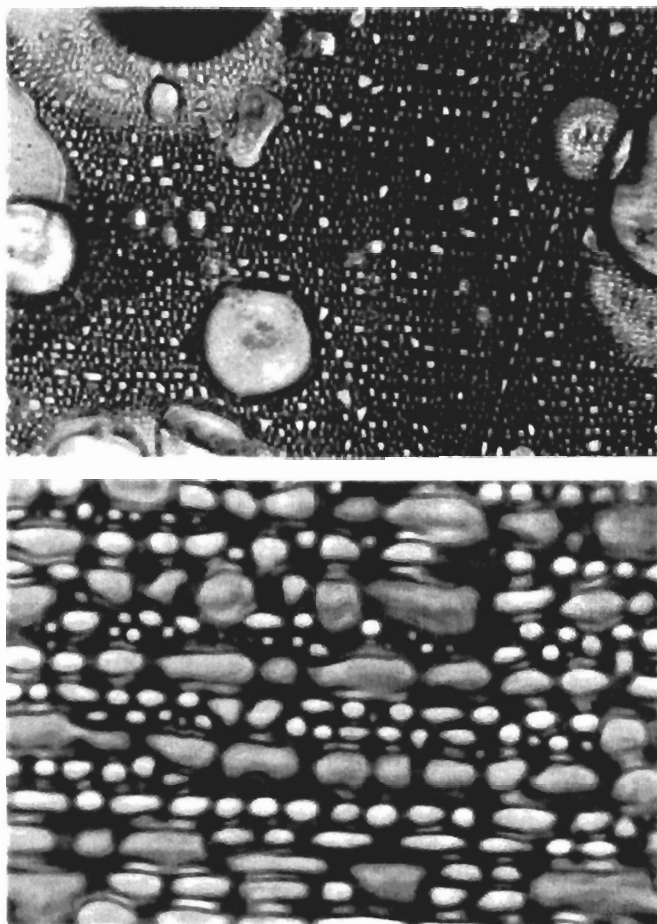

Figure 4.22. The top picture depicts under a 10× magnification a liquid magnecule composed of a bond between fragrance oil and water, the lower picture showing its 100× enlarged view. The pictures were obtained by the Givaudain-Roure Research Laboratories in Dubendorf, Switzerland. It should be indicated that the bubbles are partially fragrance oil and partially water, while the magnecule is the entire dark area of the pictures, which area was transparent water prior to Santilli's formation of the magnecular bond. Therefore, liquid magnecules may have specific weights of 10,000 amu or more, and are generally visible to the naked eye. It is instructive to know that tests at the same laboratory via an LC-MS conventionally set to identify oil fragrance molecules, showed no presence at all of any magnecular species because the analysts refused to use the largest available feeding line. In so doing, the analysts prohibited the admission in the LC-MS of the very species to be detected. This occurrence, rather frequent for analysts whose mind remains set at molecular detections, is confirmed by the fact that the LC-MS did detect the fragrance oil and water, but failed to provide any detection at all of the dark liquid of the pictures.

CONDITION III: The production of the alternative fuel must be energy efficient, in the sense that the energy content of the fuel must be bigger than the energy used for its production. This condition eliminates ethanol, hydrogen and other alternative fuels under their current production methods since their energy content is a fraction of the energy used for their production.

CONDITION IV: The alternative fuel must be cost effective as a necessary prerequisite for its actual use by individuals with consequential prevention of the indicated catastrophes. This condition eliminates ethanol, hydrogen and other fuels as a viable alternatives because they are currently more expensive than gasoline for the same energy content and are predicted to remain so under known production technologies.

CONDITION V: The alternative fuel must be environmentally acceptable on global grounds, including production, storage and combustion. This condition eliminates hydrogen as currently produced from fossil fuels or via the electrolytic separation of water under commercially available electricity because in both case the pollution caused by hydrogen production is bigger than that caused by gasoline production and combustion. Additionally, current methods for hydrogen production and combustion cause "oxygen depletion," one of the most serious environmental problems I introduced at the 2000 World Hydrogen Conference in Munich, Germany, consisting of the permanent removal of breathable oxygen in our atmosphere and its conversion into forms not usable for breathing. In fact, fossil fuel combustion converts O_2 into CO_2 that is no longer recycled by our plants due to the enormous volumes of daily production. Hydrogen is a beautiful fuel when is produced from:

- 1) Renewable energy sources, such as solar, wind or hydro-energy;
- 2) Via the electrolytic separation of water; under the additional condition that
- 3) The produced oxygen is freely released in the atmosphere for being recaptured by hydrogen combustion as a necessary condition to maintain the current oxygen percentage in our atmosphere.

By contrast, the oxygen produced in electrolytic separation of water is nowadays sold and used for fertilizers, food, metal cutting, and other uses none of which make oxygen available for hydrogen combustion. Under these conditions, hydrogen combustion causes a very serious oxygen depletion evidently given by the conversion of atmospheric oxygen into H_2O , that is not appreciably recycled by plants into breathable oxygen also in view of the very large volume of water existing in our planet.

To understand the gravity of oxygen depletion, responsible individuals should note that we have accumulated in our atmosphere an estimated number of one billion tons of excess CO_2 from fossil fuel combustion and hydrogen production. The O_2 in CO_2 was originally breathable oxygen and it is now no more. But O_2

constitutes about 72% of CO₂. Therefore, we have eliminated from our planet an estimated number of 720 million tons of breathable oxygen.

In the event hydrogen is allowed to have a large scale automotive and other uses, because of the depletion of oxygen into CO₂ caused by its current production plus the depletion of oxygen into H₂O caused by its combustion, human life on Earth would be extinct in a few years because of the reduction of breathable oxygen below the level needed to sustain human life.

The understanding of Santilli's discoveries by responsible individuals requires the knowledge that his fuels with magnecular structure, generically called *magne-gases*, are the only known fuels meeting Conditions I-V while being industrially available NOW. Additional understanding of the societal relevance of Santilli's discoveries will be presented in the next chapters in relation to truly new and clean energies.

4.4.B Santilli hadronic reactors (1998)

Submerged electric arcs were discovered in the 19th century for the repair of metal ships. The production of a gas and its combustible character were discovered at the same time by sailors who used to lit up the gas emerging from underwater welding and called it "fire on water." The clean burning character of the gas was also known at that time. Despite the above promising features, submerged electric arcs did not reach industrial relevance for the production of a combustible gas since their discovery in the the 19th century until Santilli's studies in the late 1990s.

Recall from Section 4.3 that Santilli had selected submerged electric arcs for the production of his new magnecular species. Therefore, he initiated the systematic study of submerged electric arcs in 1998. By proceeding with his typical analytic method, Santilli first identified the main limitations of submerged electric arcs, and then conducted systematic theoretical and engineering studies for their resolution by using his knowledge of hadronic mechanics and chemistry.

In essence, electric arcs submerged within a stationary liquids have a very low *Efficiency E* defined as the ratio between the volume *V* in scf of gas produced and the electric energy *E*_{elec} needed for its production expressed in Wh

$$E = V/E_{\text{elec}}. \quad (4.28)$$

Electric arcs between carbon electrodes are indeed very efficient in the separation of water molecules by producing a plasma of mostly ionized H, O and C atoms around the electrode tips. However, the passage of the arc through the H and O atoms causes their combustion into H₂O via an implosion, thus resulting in a very low efficiency *E*, with consequential excessive cost for the combustible gas, because most of the separated water molecules are then recombined.

Stationary submerged electric arcs have additional shortcomings, such as the production in the plasma of an excessive percentage of CO_2 , measured up to 18% prior to combustion (and 27% in the combustion exhaust), due to the synthesis of CO in the presence of O atoms while being traversed by the arc.

Santilli conducted systematic engineering studies for the resolution of the above insufficiencies by developing a new method called *PlasmaArcFlow* (PAF, patented and international patents pending), consisting in continuously flowing the liquid feedstock through the arc, then controlling the cooling down of the plasma in the surrounding liquid, and controlling the formation of the combustible gas with magnecular structure, while the latter is cleaned by its bubbling through the liquid. This *new PAF process* does indeed allow the production of a clean burning, cost competitive magnecular gas ready for combustion at the time of its production without any need for additional refining.

PlasmaArcFlow Refineries are known scientifically as *Santilli hadronic reactors* because of their conception and engineering realization via the use of hadronic mechanics and chemistry due to excessive divergences between the predictions of quantum theories and experimental data outlined in Figure 4.23 and Chapter 6. In this respect, Santilli states:

As an editor of various journals, I continue to receive papers to this day attempting to represent the structure of the hydrogen atom with Newtonian mechanics despite the availability for about one century of its exact quantum solution. Therefore, it is very easy to predict that the manifestly nonlinear, irreversible and non-Hamiltonian processes caused by submerged electric arcs will indeed continue to be studied with the manifestly linear, reversible and Hamiltonian special relativity and quantum mechanics, despite the availability of numerically exact and invariant solutions via the nonlinear, irreversible and non-Hamiltonian genomechanics, thus resulting in the mere illusion of serious research.

A main feature of Santilli hadronic reactors is their high efficiency with an energy output that is a multiple of the used electric energy. This important feature is due to the fact that the primary source of energy of hadronic reactors is not the electric energy of the arc, but *carbon combustion* in the plasma. As a matter of fact, Santilli conceived his reactors for the primary purpose of developing a *new, cleaner and more efficient carbon combustion*.

In the plasma of an electric arc between carbon electrodes submerged in water we have all chemical reactions of the conventional combustion of carbon in air, such as the synthesis of CO with the release of 288 Kcal/mole, the synthesis of CO_2 with the release of 87 Kcal/mole, and others. Additionally, in the plasma of hadronic reactors we have the synthesis of H_2 with the release of 110 Kcal/mole that does not occur in conventional carbon combustion in air, thus showing that Santilli's combustion of carbon in the plasma of an arc has a bigger energy output of the combustion of the same carbon in air. The environmental qualities of a

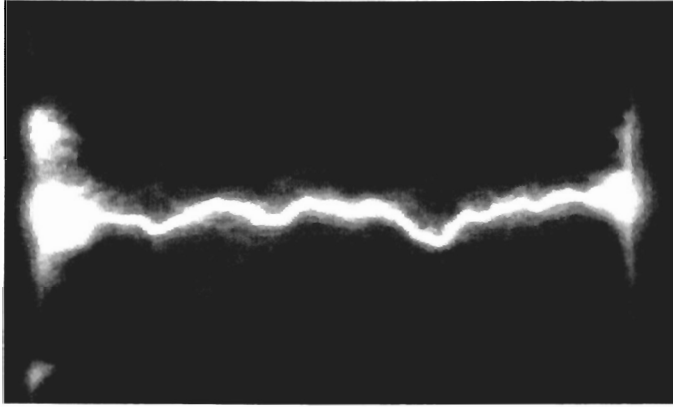

Figure 4.23. A beautiful picture of a DC electric arc between graphite electrodes submerged in distilled water that constitutes, jointly with the valence and other events, a case of clear inapplicability of 20th century theories. To begin, Maxwell's equations and special relativity are certainly applicable to an arc in vacuum (or at best in air), but they are fundamentally inapplicable for the same arc when submerged in water because of the impossibility of representing: the dielectric character of water; the existence of the longitudinal, attractive, Ampere force between the two electrodes (that is basically incompatible with Maxwell's equations); the collapse of the resistance under a closed arc; and other aspects. Similarly, quantum chemistry predicts that the gas produced under the considered conditions is composed of close to 50% hydrogen and 50% carbon monoxide plus traces of carbon dioxide and other substances, a prediction that is dramatically disproved by GC-MS analyses (see Figure 4.12). Additionally, quantum chemistry predicts the absence of oxygen in the exhaust, while experimental measurements show the presence in the exhaust of up to 14% breathable oxygen, plus having additional deviations from quantum predictions with errors of the order of at least ten times the experimental data (see FHC for details). Hadronic mechanics and chemistry have resolved these insufficiencies for which reason the equipment producing magneuclear gases via submerged electric arcs are called "Santilli hadronic reactors."

carbon combustion via a submerged arc is evident because all solids and liquid contaminants are trapped in the liquid and then eliminated by the arc.

To study these aspects, Santilli has introduced first the *Scientific Efficiency* (SE) of hadronic reactors given by the total energy output (as the sum of the energy in the gas E_{gas} plus the heat acquired by the liquid E_{liquid}) divided by the total energy input (as the sum of the used electric energy E_{electr} and the energy of carbon combustion E_{carb}), which Scientific Efficiency is always *smaller than 1*, and we write

$$SE = (E_{\text{gas}} + E_{\text{liquid}})/(E_{\text{electr}} + E_{\text{carb}}) < 1. \quad (4.29)$$

However, hadronic reactors recycle liquid wastes that are generally very rich in carbon, such as engine oil waste, cooking oil waste, etc. In this case, *the carbon brings an income*, rather than carrying a cost. As a result, Santilli introduced the *Commercial Efficiency* (CE) given by the Scientific Efficiency without the

carbon energy in the denominator. Since the latter is a large multiple of the electric energy (see FHC for details), it is then evident that the Commercial Efficiency is *much bigger than 1*, and we write

$$CE = (E_{\text{gas}} + E_{\text{liquid}})/E_{\text{electr}} > 1. \quad (4.30)$$

In fact, small hadronic reactors (say with 50 kW) have a Commercial Efficiency of the order of 5, namely, *for each unit of electric energy input, the reactors produce up to five units of energy output as a combination of thermal energy in the combustible fuel and heat acquired by the liquid feedstock.*

As we shall see in Chapter 6, the above high efficiency cannot be numerically explained via the sole use of conventional chemical reactions, such as the synthesis of CO, CO₂, etc., and requires the admission of *novel nuclear processes*, that, if properly enhanced, can give an energy output 50 times or more the used electric energy.

In regard to *cost* of the magnegas fuel produced with hadronic reactors, we recall that, in their industrial version with a minimum of 300 Kw power, operating in the “total mode” at a minimum pressure of 100 psi, at the temperature of 200°F while processing an oil-base liquid feedstock, hadronic reactors require approximately 70 W = 220 BTU of electricity for the production of 1 scf of fuel with about 900 BTU/scf, plus 300 BTU of heat acquired by the liquid feedstock with a total $CE = 5.95$, the excess energy originating from the chemical and nuclear reactions in the plasma of the hadronic reactor.

One gasoline gallon contains about 110,000 BTU. Therefore, the *Gasoline Gallon Equivalent* (GGE) of magnegas is given by 110,000/900 = 122 scf. The production of one GGE of magnegas requires 122 × 70 W = 8.5 kWh that, at the current rate of 0.08/kWh yields the electricity cost of 0.68/GGE.

The computation of the total direct cost of one GGE of Magnegas requires the *addition* of 30% for other direct costs, including carbon electrodes, service and amortment of purchase prize over 15 years, yielding the total direct cost of 1.08 per GGE, *less* the income for the recycling of the liquid waste that generally reduces considerably the direct costs and, in certain special case, can be *bigger* than the direct cost.

4.4.C Industrial realization of MagneGas fuel (1998)

Following the above basic research, Santilli conducted systematic engineering work for the optimization of the PAF method and industrialization of the process into completely automatic and remote controlled *PlasmaArcFlow Refineries* of various dimensions and powers for the gasification of a variety of liquid wastes into *MagneGas* fuel of which he introduced the name as well as the chemical symbol MG.

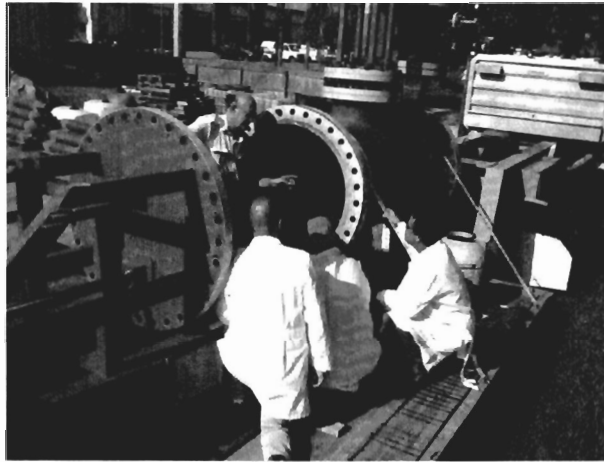
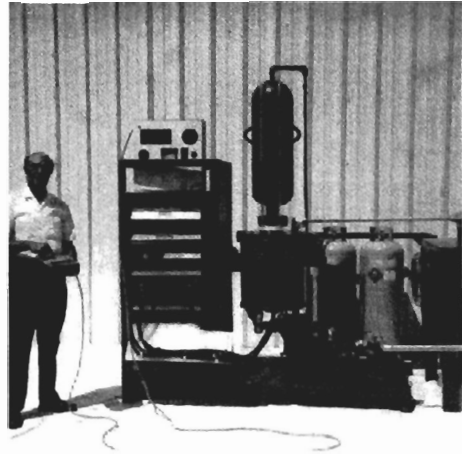
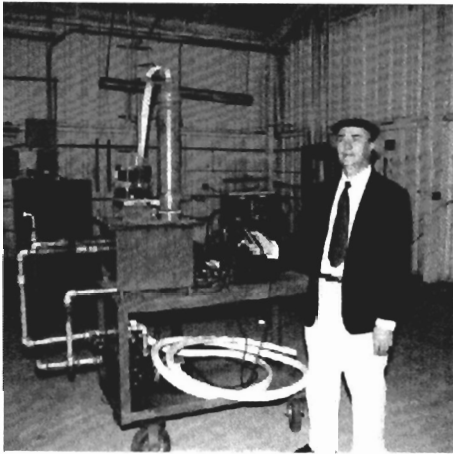

Figure 4.24. Views of some of the various hadronic reactors built by Santilli for pure research purposes. The top view shows the first manually operated hadronic reactor built in late 1998 to test the PlasmaArcFlow principle with minimal costs. Because of encouraging results, Santilli built a series of sequentially improved research reactors to test the various aspects of the new technology, the middle picture showing a completely automatic 50 kW hadronic reactor built in 2001. Numerous additional research reactors followed. The bottom pictures shows a large 500 kW research reactor built in 2005 and still used by Santilli for various tests, particularly those of nuclear character outlined in Chapter 6 (the bottom pictures shows from the left Santilli and three of his technicians: Michael Rodriguez, John T. Judy, and Eugene West).

In so doing, Santilli obtained the U.S. Patents 6,926,872, 6,673,322, 6,663,752, 6,540,966, and 6,183,604 whose study is suggested for any in depth knowledge of this new technology. A U. S. corporation was set up with public listings of its stock that is now in production and sale of MagneGas in the American continent, MagneGas Corporation <http://www.magnegas.com> with affiliated companies for

the development of the MagneGas Technology in India, Europe, Australia and other countries.

MagneGas does indeed verify Conditions I–VI of Section 4.4A for an effective progressive replacement of petroleum fuels in view of the following main aspects:

1. MagneGas can be effectively used in all existing gasoline engines (see Picture 4.19 on various cars currently using magneGas);

2. MagneGas is produced from liquid waste available everywhere in unlimited volumes, such as engine oil waste, cooking oil waste, city, farm and factory liquid wastes, etc;

3. MagneGas production is energy efficient, because its energy content is bigger than the electric energy needed for its production, as outlined in the preceding sections via the notions of Scientific and Commercial Efficiencies;

4. MagneGas is less expensive than fossil fuel when produced in sufficient volume by assuming an income for the recycling of the liquid waste, as also outlined in the preceding section;

5. MagneGas is environmentally acceptable because it admits complete combustion, thus having no HC, CO or other contaminants in its exhaust (see Figure 4.27).

Additionally, one should bear in mind that **MagneGas is industrially available now**. In fact, it is in regular production and sale in various countries. For additional information, one may visit the following links:

- Fox News video on the MagneGas Technology:
<http://www.youtube.com/watch?v=WmYfDZcyBjc>;
- Video by Dunedin Water Treatment Plant:
http://www.youtube.com/watch?v=0C6r_6evo4k;
- Invited presentation at the United Nations:
<http://www.un.org/webcast/csd15/csd15-h.htm>;
- Video by MagneGas Corporation:
<http://www.youtube.com/watch?v=NDpDZWnRc4>.

As Santilli puts it: *During WWII, Germany had no major petroleum reserves and synthesized most of its fuel in both their gaseous and liquid forms for use in cars, tanks as well as airplanes. In fact, the catalytic liquefaction of gaseous fuels, today called Fisher-Tropsch, was discovered in Germany during that period. A country synthesizing its fuels to fight the rest of the world some sixty years ago is incontrovertible evidence that, today, some sixty years later, our dependence on petroleum fuels is a purely political occurrence, since there is no possible or otherwise credible doubt on the technical capability today by any country achieving fuel independence.*

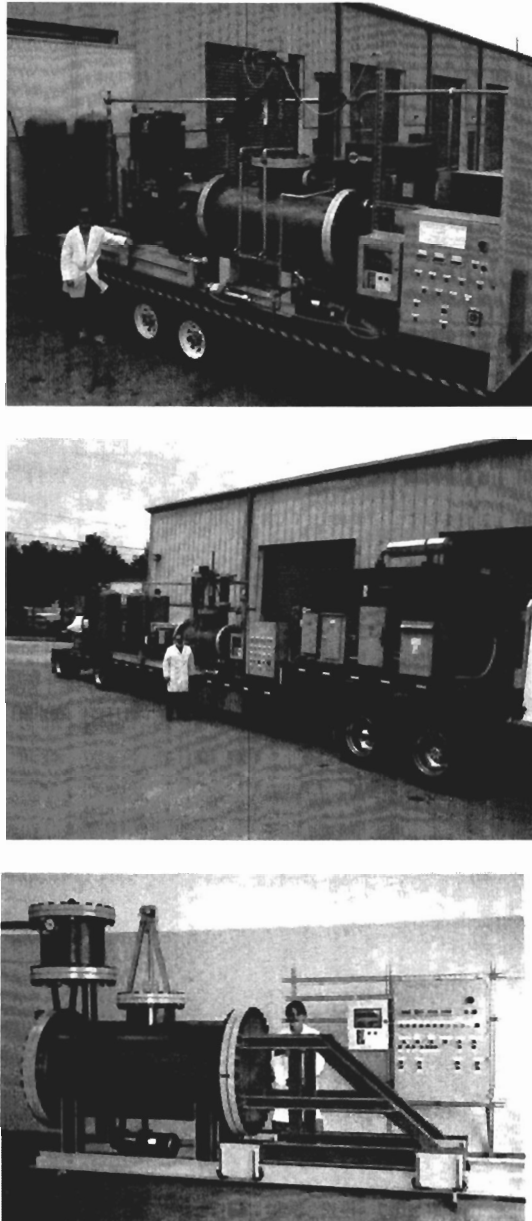

Figure 4.25. A view of various industrial hadronic reactors built by Santilli: the top view shows a 50 kW Magnegas Refinery on a trailer operated by Richard Lyons, one of Santilli's technicians; the middle view shows a 100 kW refinery on a trailer operated by John T. Judy; and the bottom view shows the PlasmarcFlow Module of a 500 kW floor mounted industrial Magnegas Refinery.

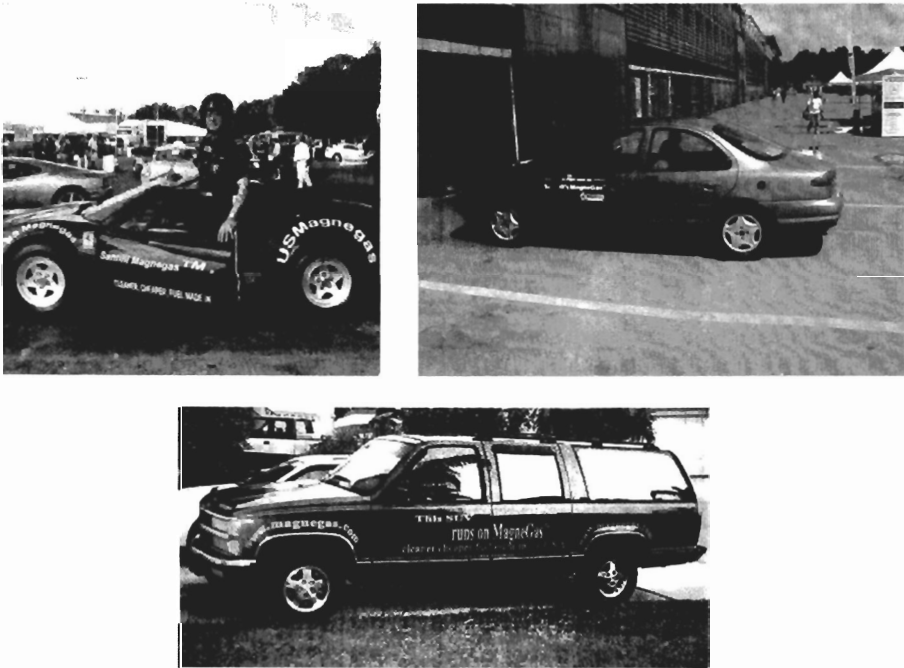

Figure 4.26. A view of some of the numerous cars prepared by Santilli to operate on MagneGas. The picture from the top shows Santilli with a Ferrari 308 GTSi 1981 he converted to operate on MagneGas while being tested in 2001 at various Florida race tracks, including Sebring, Moroso and others, to show that the car accelerates faster and revs higher than the same car running on gasoline due to the high octane of MagneGas (about 130), the lower temperature of the combustion exhaust (about 30% lower) due to about 50% of water vapor in the same exhaust, and other factors. The middle picture shows a Ford Contour 1999 bifuel (namely, operating on gasoline and natural gas, with a switch on the dash for the change of fuel), operated on MagneGas in lieu of natural gas without any change, while being tested at the Race Track in Monza, Italy, in June 2008. The bottom picture shows a Chevrolet Suburban 1994 produced for the sole operation on gasoline, with the additional equipment needed to operate on MagneGas that is daily used by Santilli, gasoline being used for refueling when MagneGas is depleted.

4.4.D Industrial realization of the HHO fuel (2006)

Another fuel with a magnecular structure studied in detail by Santilli is that produced via a special electrolyzer that turns distilled water into a very powerful, combustibile, and gaseous form for which he introduced the chemical name of *HHO*. Prior to Santilli's studies, a similar gas was known under the name of *Brown gas* but referred to a perfect stoichiometric mixture of 2/3 ordinary hydrogen and 1/3 ordinary oxygen gases.

However, Santilli showed that a 70–30 mixture of H_2 and O_2 does not possess the special features of the HHO gas, such as that of instantaneously melting

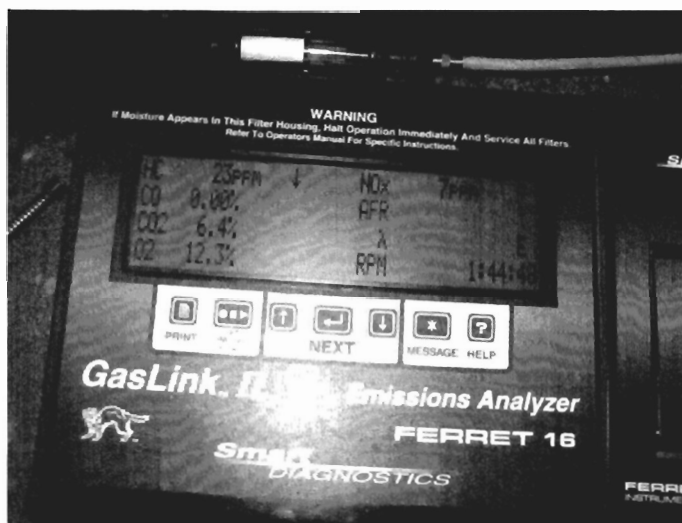

Figure 4.27. A picture of the reading of an exhaust analyzer showing the combustion exhaust of the cars of the preceding figure, the exhaust being sensed at the manifold, thus prior to the catalytic converter. The data show the main characteristic of MagneGas of being a fuel with complete combustion, thus without contaminants in the exhaust. In fact, MagneGas exhaust is composed of about 50% water vapor, 12% to 14% breathable oxygen, 5% to 7% carbon dioxide, and the rest is given by atmospheric gases. We should note that the detected HC originate from the seepage of engine oil through the piston rings in a rather old car, since MagneGas is produced at 10,000°C at which temperature no HC can survive. Similarly, CO is produced by the combustion of fossil fuels, while CO is a fuel component for MagneGas. Therefore, any presence of CO in the MagneGas exhaust is equivalent to the presence of gasoline in the exhaust of a gasoline operated car, namely, both are evidence of lack of proper combustion (for detail see the quoted specialized literature).

tungsten and bricks at flame contact. Hence, he conducted systematic experimental measurements establishing that at least a percentage of the HHO gas has a magnecular structure. Such a percentage is then crucial for the stability of the gas, e.g., to avoid the perfect stoichiometric ratio of hydrogen and oxygen for selfcombustion. The results of the studies have been reported in historical paper [121] (we cannot possibly review here for brevity).

It should be stressed that, due to two years of delays between the date of acceptance of the above paper and that of its publication, a considerable confusion resulted and *the above quoted printed version is NOT the final version approved by Santilli but that of uncorrected galleys with several garblings such as those in the symbols as well as misprints*. For the correct version, we refer the reader to monograph [25].

The research herein considered was conducted by Santilli as a scientific consultant of the American company *Hydrogen Technology Applications, Inc.* which

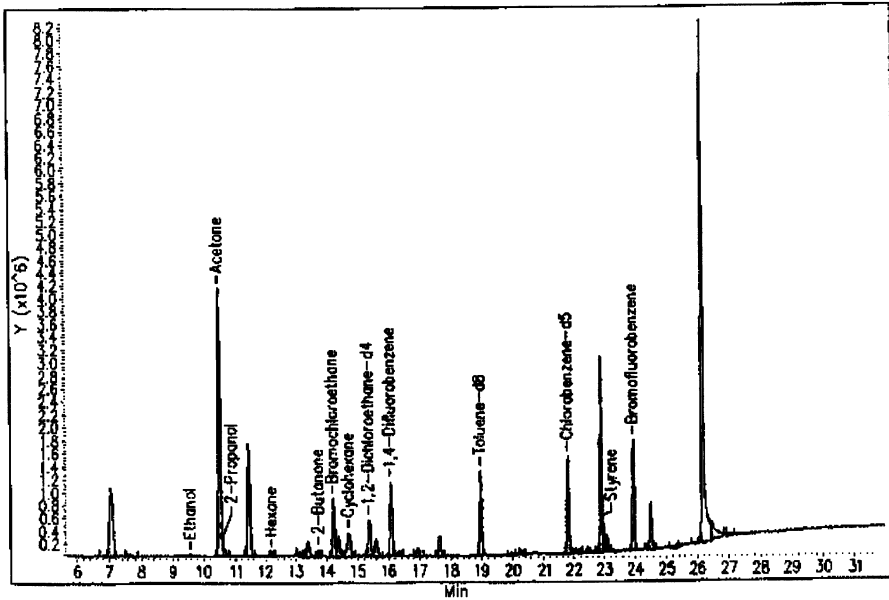

Figure 4.28. Experimental evidence of the magnecular structure of the HHO gas: a printout of the blank following completion of the scans with a GC-MS and removal of the gas from the instrument. For all conventional molecular gases, the blank solely shows background data none in macroscopic percentage. By contrast, the blank of this figure is essentially similar to the ordinary scan under the precautions indicated in Section 4.3 (sufficiently large feeding line, low column temperature, longest possible elusion time, etc.). Since the HHO gas was removed from the instrument, the above printout establishes the magnecular character of the gas via its anomalous adhesion to the walls of the instrument. Additionally, the scan shows a number of species in macroscopic percentage other than H_2 and O_2 that can only be explained as magnecular clusters comprising combinations of H or O, HO, H_2 , O_2 , and H_2O , since the gas originates from distilled water.

company is the owner of all intellectual rights and is currently producing and selling the HHO gas on a world wide basis under the commercial name of *Aquygen*TM. More details can be obtained from the website <http://hytechapps.com>.

4.4.E Industrial realization of MagneHydrogen fuel (2003)

Santilli has been very supporting of hydrogen as a fuel to such an extent that he dedicated years of research to the field. In particular, he supports the environmentally acceptable production and combustion of hydrogen consisting of:

1) Hydrogen should be produced via clean renewable sources of electricity, such as those of wind, solar or hydro-origin;

2) The clean electricity is used for the electrolytic separation of water; and, above all,

3) The oxygen produced in the process is released in the atmosphere so that the combustion of hydrogen reacquires said oxygen by maintaining unchanged the oxygen balance in our planet.

In reality, the current production and use of hydrogen is dramatically different than the above sound environmental lines, by causing the following serious environmental problems:

A) Hydrogen is generally produced from electrolytic separation of water via currently available, environmentally unacceptable sources of electricity. Alternatively, hydrogen is produced via the reformation of fossil fuels that notoriously cause a pollution bigger than that caused by gasoline combustion. Since the energy needed for hydrogen production is bigger than its energy content, under the condition here considered there is no real environmental or other gain in the use of hydrogen as fuel.

B) In case hydrogen is produced from the electrolytic separation of water, the produced oxygen is captured and sold for various scopes, rather than released in the atmosphere, in which case the oxygen balance in our planet is lost at the time of oxygen combustion. For instance, when oxygen is sold for metal cutting, it is turned into iron oxides. Consequently, the combustion of hydrogen, whether in an engine or a fuel cell, causes *oxygen depletion* (Section 4.4A), namely, the permanent removal of breathable oxygen from our planet and its conversion into water vapor.

C) Assuming that the above environmental aspects are solved, hydrogen remains with serious additional problems, such as that of seepage through the walls of containers due to its extremely small size, thus causing known storage problems.

D) Hydrogen is the lightest gas in nature. Therefore, when released in the atmosphere due to seepage or other reasons, it rises very rapidly to the ozone layer where it causes the additional environmental problem called *ozone depletion*, namely, the permanent removal of ozone from our atmosphere with consequential increase of skin and other forms of cancer, due to the very fast chemical reaction (that has no equivalent for other fuels and their exhaust)



E) Additionally, hydrogen has a limited amount of energy content, thus causing known storage problems to reach a desired range. In fact, hydrogen has 300 BTU/scf, while gasoline has about 110,000 BTU/g. Consequently, the Gasoline Gallon Equivalent (GGE) for hydrogen is $110,000/300 = 360$ scf. It then follows that to reach the same range of a tank with 30 gallons of gasoline, there

is the need of $30 \times 360 = 10,800$ scf, namely, a volume of hydrogen so large that it cannot be effectively stored in a car. This limitation has requested the cryogenic liquefaction of hydrogen by some automakers, which liquefaction renders the cost of hydrogen simply prohibitive for the foreseeable future since hydrogen liquefies close to the absolute zero degree temperature. Additionally, hydrogen must be continuously maintained at the liquid state irrespective of whether the car is used or not, thus causing additional costs as well as danger in the event the on board cryogenic system fails, since in this case there is an explosive transition from the liquid to the gas form due to the very fast change of volume, rather than combustion.

With his typical research style, Santilli addressed systematically all the above problems and searched for their solution in support of hydrogen as a fuel. Firstly, he developed the MagneGas Technology also in support of hydrogen since MagneGas contains a minimum of 60% hydrogen in a *mixture* with other gases, thus being of easy separation via membranes or other separation processes. This new form of hydrogen production has numerous advantages over conventional production, such as:

I) An acceptable energy efficiency, since the energy needed for hydrogen production is smaller than its energy content thanks to the very high efficiency of hadronic reactors, thus alleviating the use of environmentally unacceptable electricity for hydrogen production;

II) A significant reduction or elimination of oxygen depletion, because MagneGas is rich of oxygen originating from *liquids*, rather than from the atmosphere; and

III) A major reduction or elimination of the ozone depletion, because the hydrogen produced from MagneGas has no seepage due to its magneuclear structure that seals the walls of all containers via layers of atoms bonded by magnetic induction, as established by various tests.

Additionally, Santilli developed yet another fuel with a magneuclear structure under the name of *MagneHydrogen*, today known under the chemical symbol MH. The objective was to avoid the cryogenic liquefaction of hydrogen via the increase of its specific weight because, in the event the specific weight of hydrogen can be increased by a factor of 3, the "heavy" species of MH would reach an energy content equivalent to that of natural gas, thus avoiding any need for cryogenic liquefaction, with evident benefits for the hydrogen industry, such as dramatically reduced costs, increased range, etc.

As it is well known, there is no possibility of increasing the specific weight of hydrogen under a valence bond because valence electrons couple in pairs, resulting in the conventional molecular structure $H_2 = H - H$ with specific weight 2.016 amu. By contrast, magneuclear bonds have no theoretical limit in the number of bonded atoms, the limit being set by the temperature and other conditions.

It is then evident that the only possibility for increasing the specific weight of hydrogen is that via magnecular bonds, hence the name of MagneHydrogen.

Santilli also searched for means to produce a form of MagneHydrogen with specific weight bigger than 2.016 amu. Following various trials and errors, he developed a process consisting in passing MagneGas through a zeolite selected for hydrogen purification; collection the hydrogen released; and then passing it again at pressure through the same zeolite seven consecutive times. The species of hydrogen produced in this way resulted to have about *seven times* the specific weight of conventional hydrogen (see Figure 4.29 for more details).

The research herein outlined was conducted by Santilli as scientific advisor of the U. S. corporation *Clean Energies Tech, Inc.* that is the sole owner of all intellectual rights. A vast industrial effort is under way at this writing (Spring 2009) to organize the industrial production of MagneHydrogen.

To clarify the discovery, the hydrogen collected following the first passage of MagneGas through the zeolite is expected to have indeed a magnecular structure, but with a minimal increase of the specific weight over that of the hydrogen. The subsequent passages of the species through the same zeolite essentially cause the accumulation under pressure of polarized hydrogen clusters along opposite polarities North-South-North-South-..., resulting in a sequence of magnecular clusters of the type

$$MH_1 = H, \quad (4.32)$$

$$MH_2 = H - H + H \times H, \quad (4.33)$$

$$MH_3 = (H - H) \times H + H \times H \times H, \quad (4.34)$$

$$MH_4 = (H - H) \times (H - H) + H \times (H - H) \times H + H \times H \times H \times H, \text{ etc.}, \quad (4.35)$$

whose main limitation is that of their breakdown due to collisions caused by temperature.

The main reference of the discovery of MagneHydrogen is the additional historical paper of 2003 [118] whose pdf file contains copies of the signed laboratory reports as well as the monographs previously quoted.

4.5 Santilli Discovery in Biology

4.5.A Historical notes

There is no doubt that Santilli achieved his most advanced discoveries in biology whose foundations are outlined in monograph [16].

In this section we shall attempt a conceptual review of these advances with the understanding that such a task is faced with serious difficulties due to the complexity of the conceptions as well as of the mathematics used for their quantitative treatment. Another difficulty of this review is that Santilli has not published a number of advances in biology that have been made available to us as notes not

SPECTRALAB

6349 82nd Avenue North
 Pinellas Park, Florida 33781
 Phone: (727) 545-2297 • Fax (727) 547-8024

Component	Gas
Hydrogen	99.2
Carbon monoxide	None detected
Carbon dioxide	None detected
Methane	0.78
Ethane	None detected
Ethene (ethylene)	None detected
Ethyne (acetylene)	None detected



ADSORPTION RESEARCH INC.

6175-D Shamrock Court
 Dublin, OH 43016

Gas	Molecular Weight (g/mol or amu/molecule)
MagneGas™ [Feed]	15.60
MagneHydrogen™ [Product]	15.06
Ordinary Hydrogen [for comparison]	2.016

Figure 4.29. The measurements of the new species of MagneHydrogen (MH) produced under Santilli's directions by independent U. S. laboratories, whose directors released signed statements that have been included in the historical paper of 2003 quoted below. As one can see, the top measurements indicates that the species is composed of 99.2% hydrogen while having the specific weight of 15.06 amu, that is, 7.4 times that of hydrogen. This evidence seals in a final and incontrovertible way the existence of Santilli magnecules, by disqualifying as nonscientific any theoretical or theological doubt since only a basically new species, that is, a species with a basically new bond other than the valence, can provide a credible representation of the results.

completed for publication, although we have been told that the completion of these papers and their publication are expected in the near future.

On historical grounds, Santilli has been one of the leading scientists to establish the basic insufficiencies of quantum mechanics and chemistry for biological structures. As he puts it: *Any belief of conducting serious quantitative studies of biological structures with quantum mechanics and chemistry raises issues of scientific ethics and accountability because first year graduate students know that said theories predict biological entities to be perfectly rigid, perfectly eternal and with no reproductive capacity. Therefore, the selection of the applicable "generalization" of quantum mechanics and chemistry should indeed be subject of scientific debates, but not its need.*

It is our opinion that the year 1997 of publication of the above quoted monograph will be remembered by ethically sound scholars as signaling the transition from rudimentary studies in biology to fundamentally new and dramatically more complex scientific vistas with truly vast horizons and outcome beyond our predictive capacity.

In closing, Santilli has requested to remember Prof. Bakunin, the lady who taught him organic chemistry at the University of Naples, Italy, during his undergraduate studies in the 1950s, since his interest in biology originated from her teaching.

4.5.B *Deformability, irreversibility, and multi-valuedness of biological structures.*

The first and perhaps most important contribution by Santilli to biology has been the identification of the following main characteristics of biological structures, which identification sets the basis for the discovery of the *generalized mathematics* needed for quantitative treatments:

DEFORMABILITY. Santilli often initiates lectures in the field by squeezing in front of the audience a small rubber ball and stating: *This simple deformation of a rubber ball is incompatible with special relativity and quantum mechanics because it violates their central pillar, the rotational symmetry, from which there is a consequential inevitable violation of the Lorentz symmetry.* He then moves his fingers and states: *A main feature of biological structure is deformability requiring a dramatic departure from the 20th century theories. In the absence of a theory representing deformability from its main axioms, we know today that no invariant quantitative treatment is possible.*

IRREVERSIBILITY. Santilli then projects in the lecture screen a representative biological event, such as the birth and death of a flower, and states: *Yet another main feature of biological structures is their irreversibility over time. This feature, alone, is sufficient to rule out all dominant theories of the 20th century, since they were conceived, developed and tested to represent systems reversible*

over time, such as the structure of nuclei, atoms and molecules. Again, without methods that are irreversible in their basic axioms, we merely have the illusion of quantitative studies in biology.

MULTI-VALUEDNESS. Santilli then recalls the studies by the Australian biologist Chris R. Illert who showed that a three-dimensional Euclidean space can indeed represent all *shapes* of seashells, but the computerized use of the same space to represent the *growth* of seashells causes the latter first to grow in a deformed fashion and then crack. Santilli then states: *The basic axioms of the Euclidean space at the foundation of the 20th century theories not only provide an axiomatization of perfect rigidity and reversibility, but also the representation axes are single valued, that is, they grant one single value for each point. By comparison, Illert has shown that a more accurate representation of the growth of seashells occurs via the use of a six-dimensional space, that is, a space in which each axis is doubled.* It is evident that, when passing from the relatively “simple” seashells to complex bio;logical structures such as a DNA, the number of dimensions needed for a quantitative treatment may become beyond our intuitional capacities. For more details, one should consult Illert’s contributions in monograph [15].

4.5.C *Representation of biological structures via Santilli’s deformable, irreversible and multi-valued hypermathematics*

Illert’s doubling (in 1995) of the three Euclidean axes for the representation of seashells growth motivated the discovery in 1996 by Santilli of hypermathematics presented in historical mathematical memoir [93] and summarized in Chapter 2. As Santilli’s put’s it: *When we observe a seashell in our hands, we can fully perceive its growth via our three Eustachian lobes. The sole way to reconcile the six-dimensionality of seashell growth with our three-dimensional sensory perception is via a hyper-Euclidean space with three dimensions in which each axis is two-valued. At the abstract, realization-free level, there is no distinction between the two-valued hyper-Euclidean space and the conventional space, thus allowing our senses to perceive the seashell growth in three dimensions. By contrast, the use of a six-dimensional space would lead to irreconcilable incompatibilities between the mathematical representation and our perception of reality.*

Additionally, the multi-valued hyperspace must be irreversible as a necessary condition not to violate causality. This requirement can be implemented via the adoption of *Santilli’s multi-valued genospaces*, as presented in the above quoted mathematical memoir and outlined in Chapter 2. As the reader will recall, irreversibility is set at the most primitive level, the basic hyperunits, that are different for different directions of time, thus assuring lack of violation of causality.

Once a multi-valued irreversible genospace is assumed as the carrier space, the invariant representation of deformations follows from *Santilli’s multi-valued*

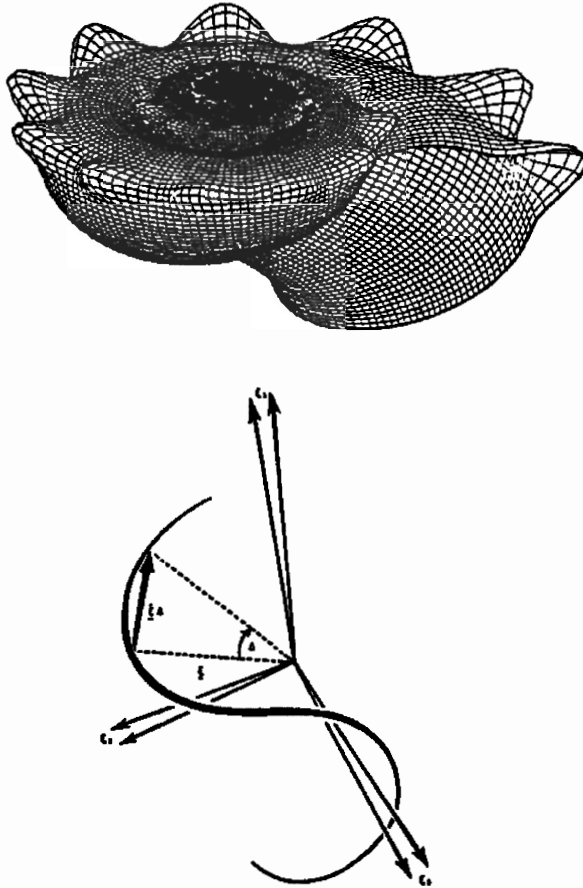

Figure 4.30. A conceptual rendering of Illert's representation of seashells growth with the doubling of the Euclidean reference axes.

hyperrotational symmetry, namely, the isorotational symmetry at the foundation of isorelativity and hadronic mechanics (Sections 3.10 and 3.11) in which the basic isounits are first differentiated for motions forward and backward in time, and then they are assumed to be multi-valued. The invariant representation of deformability under multivaluedness then follows, jointly with the bypassing of the Theorems of catastrophic Inconsistencies outlined in Section 3.7.

A comprehensive study of the isorotational symmetry and related isotrignometry is available in monographs [12, 14].

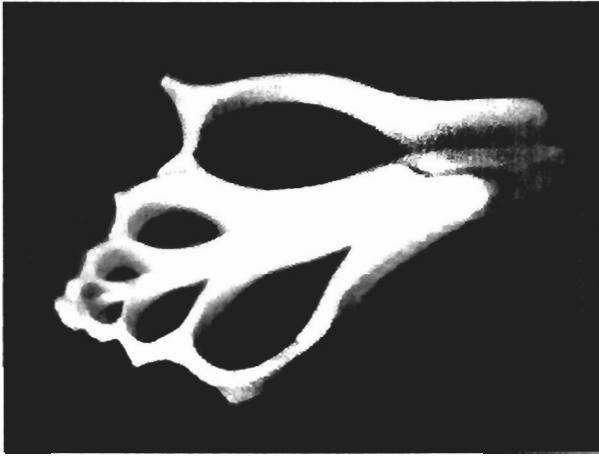

Figure 4.31. The slicing of a small seashell showing the various bifurcations despite its small size. The notion of time needed for a quantitative representation of the construction by the seashells of all these bifurcations is so complex to be truly beyond human comprehension. It can be represented via Santilli's hypertime consisting of the ordered set of four motions in future and past time, each one being multi-valued.

The deformable, irreversible and multi-valued hyperrotational symmetry is then achieved via the reformulation of isomathematics into the hypermathematics outlined below.

We assume the reader is aware of the differences between *Santilli's hypermathematics* and the conventional *hyperstructures*. Both are multi-valued, but the former consists of a comprehensive, multi-valued irreversible lifting of the entire mathematics, including units, numbers, spaces, symmetries, algebras, geometries, topology, etc., all based on *conventional* operations. By contrast, hyperstructures are generally reversible over time, are based on abstract hyperoperations and do not possess left and right units, under which conditions there is no direct and consistent application to experimental measurements.

For clarity, hypermathematics that can be outlined, separately, for hypertimes and hyperspaces.

SANTILLI HYPERTIMES

The need for the representation of biological structures via Santilli deformable, irreversible and multi-valued hypermathematics has been confirmed by various different approaches. One of them is by identifying the notion of *time* needed for biological structures. Illert has shown that a necessary condition for a seashell to form *bifurcations* is to master all directions of time that, contrary to popular belief, are *four*, being given by: *motions forward and backward in future time and in past times*.

The sole known rigorous representation of the above occurrence is via Santilli multi-valued hypermathematics and its isodual. In fact, the conjugation of widespread use in the 20th century, time inversion, can only represent the transition from motion forward to future times into backward in past time (represented with upper “f” and “b”, respectively). The sole known way to achieve the remaining two directions of time is via Santilli isoduality (2.9) (represented with an upper “d”). We have in this way the following *Santilli’s four different hypertimes*

$$t = \{t^f, t^b, t^{fd}, t^{bd}\}, \tag{4.36}$$

$$t^f : \text{Motion forward in future times,} \tag{4.37}$$

$$t^b : \text{Motion backward in past times,} \tag{4.38}$$

$$t^{fd} : \text{Motion forward in past times,} \tag{4.39}$$

$$t^{bd} : \text{Motion backward in future times.} \tag{4.40}$$

Eqs. (4.43)–(4.47) merely initiate the illustration of the complexities of biological structures. In fact, Santilli’s hypermathematics is based on hyperunits, as shown in Chapter 2, that are generally different for different times (as well as different space components), and we have the following *time hyperunits*

$$I^t = \{I^{tf}, I^{tb}, I^{tfd}, I^{tbd}\}. \tag{4.41}$$

Therefore, the four different times (4.43) are not measured with respect to the conventional unit of time, say, 1 sec, but each hypertime is measured with respect to its own hyperunit, by continuing to illustrate the complexity of biological structures. In fact, the four hypertimes, to be hypernumbers, must have the explicit structure

$$t^f = t_1 I^{tf}, t^b = -t_2 I^{tb}, t^{fd} = -t_3 I^{tfd}, t^{bd} = t_4 I^{tbd}, \tag{4.42}$$

where $t_k, k = 1, 2, 3, 4$, are conventional positive numbers. The complexity of biological structures is further illustrated by the fact that *each hypertime and related hyperunit can be multi-valued*,

$$I^t = \{(I_1^{tf}, I_2^{tf}, \dots), (I_1^{tb}, I_2^{tb}, \dots), (I_1^{tfd}, I_2^{tfd}, \dots), (I_1^{tbd}, I_2^{tbd}, \dots)\}. \tag{4.43}$$

But, each hypertime characterizes its own hyperspace. Thus, already at this introductory level we see the need for *four-values hyperspaces*, and we write,

$$S^t = \{S^f, S^b, S^{fd}, S^{bd}\}, \tag{4.44}$$

each component being multi-valued. But we perceive the growth of a seashell with our sensory perception based on a unique time evolution. The sole known way to achieve compatibility between the multi-valued mathematics needed for

biology and our single-valued evolution in time is that via Santilli hypertime since, at the abstract realization-free level the multi-valued character disappears. Alternatively, we can say that the abstract, realization-free axioms characterize our sensory perception of time, while actual calculations are done with specific multi-valued realizations.

More explicitly, Santilli states that the ordinary time t perceived by us is realized into the four-fold times (4.43) and, correspondingly, our time unit $I^t = 1$ sec is factorized into the four hyperunits of Eq. (4.48), each one possibly being multi-valued as in Eqs. (4.50) depending on the complexity of the case at hand. For the case of Illert’s seashells, the four hyperunits can be single-valued resulting in the conventional four directions of time (4.44)–(4.47). However, for more complex biological structures, each hyperunit can be multivalued, resulting in Eqs. (4.50).

In this way, we are naturally forced to distinguish the *observer time*, which is our perception of time, and the *intrinsic time*, which is of such a complexity as being outside our intuition and solely representable with mathematical language.

As an illustration, consider only the forward hypertime. Its hyperunit I^f can have positive-definite but arbitrarily small or arbitrarily large values. Even though we perceive a seashell in our hands with our observer’s time, in its own internal perception the seashell can be in the extreme past or the extreme future. The addition of the remaining three hypertimes illustrates again the inability of our limited mental capacity to understand the complexity of a relatively “simple” biological structure such as a seashell, much bigger complexities being expected for the DNA structure.

SANTILLI HYPERSPACES

Let us pass to the outline of Santilli’s hyperspaces. Assume at the abstract level a point P in Euclidean space with coordinates $P = x, y, z$ and realize the latter in the following multi-valued *space hypercoordinates* (each set being ordered),

$$P = \{x, y, z\} \rightarrow \{(x_1, x_2, \dots), (y_1, y_2, \dots), (z_1, z_2, \dots)\}, \tag{4.45}$$

with corresponding *space hyperunits*

$$I^{\text{tot}} = \{(I_{1x} = 1/n_{1x}^2, I_{2x} = 1/n_{2x}^2, \dots), \tag{4.46}$$

$$(I_{1y} = 1/n_{1y}^2, I_{2y} = 1/n_{2y}^2, \dots), (I_{1z} = 1/n_{1z}^2, I_{2z} = 1/n_{2z}^2, \dots)\},$$

and related hyperproduct as identified in Section 2.2C. The hyperline element left invariant by the hyperrotational symmetry can be written

$$r^2 = x^2 + y^2 + z^2 \rightarrow \hat{r}^2 = (x_1^2 n_{1x}^2 + x_2^2 n_{2x}^2 + \dots) + \tag{4.47}$$

$$(y_1^2 n_{1y}^2 + y_2^2 n_{2y}^2 + \dots) + (z_1^2 n_{1z}^2 + z_2^2 n_{2z}^2 + \dots),$$

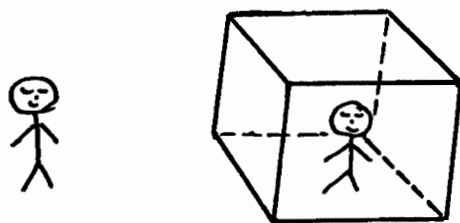

Figure 4.32. In Figure 2.1 we have described Santilli isobox, while in this figure we describe the hyperbox consisting of a box examined by two observers, an external observer in our time and space, and an internal observer in hypertime and hyperspace. For the case of the isobox, both observers are in a $(3 + 1)$ -dimensional space, the main differences being the perception of much different shapes in generally different times. For the case of the hyperbox, the differences between the exterior and interior observer become of truly difficult understanding by the limited capacities of the human mind, and can solely be treated mathematically, since the exterior observer is in a $(3 + 1)$ -dimensional space, while the interior observer is in a space with an unlimited number of folds branching into multi-dimensional universes.

which line element illustrates in a transparent way the deformability of the original perfect sphere $x^2 + y^2 + z^2$. The universal invariance is then given by the hyperrotational symmetry as indicated above.

We are regrettably forced to halt here our rudimentary review of Santilli's hypermathematics to prevent excessive length. We limit ourselves to stress, again, that the complexity of biological structures is truly beyond human intuition, as illustrated by the *hyperbox* of Figure 2.1 reproduced below under a new interpretation.

4.5.D *Hypermolecules, hypermagnecules and hyperliquids*

The origin of Santilli's prolific discoveries in so different fields is his conviction that quantitative sciences will never admit final descriptions, a limitation that he applied primarily to his own advances. As an example, following the discovery of the isonumbers (Section 2.2A) that, alone, would have assured his name in the history of mathematics, Santilli identified their limitations and, in so doing, discovered the genonumbers; then he identified their limitations and, in so doing, discovered the hypernumbers; then he identified their limitations and, in so doing, discovered the isodual numbers.

Santilli systematically applied this self-criticism to essentially all his discoveries. Consider, for instance, the achievement of the first known quantitative representation of *molecules* and their valence bond with an explicitly identified attractive valence force in complete agreement with experimental data (section 4.2). That achievement, alone, was sufficient to set his name in the history of

chemistry. Nevertheless, Santilli remained dissatisfied because he considered the advance excessively limited with respect to the complexities of nature.

Consider, for instance, the water molecule. It is popularly believed that such a molecule has one and only one representation, and that it is the same whether it is in our atmosphere or part of a cell. Santilli considers such a view rather arrogant because it assumes a final knowledge of one of the most complex structures in the universe with capabilities and feature simply beyond our imagination at this writing. In reality, there are reasons to expect that, when all features of a cell are taken into account, including its reproductive capacity, each water molecule of a cell is in some form of communication with all the remaining molecules of the same cell. Additional evidence indicates that one water molecule of one cell may well be in some form of communication with all other cells of a body, and so on.

The only quantitative way of initiating the study of such a complexity is via hypermathematics. In this way, Santilli worked out in a paper made available to the Foundation (and expected to be published soon for uploading in pdf format when completed) his model of *hypermolecules* essentially consisting in the reformulation of the molecular models of Sections 4.2 via multi-valued hypermathematics.

Santilli then applied the same self-critical analysis to his *magnecules* to discover, again, their excessive limitations for biological structure. In this way, in an additional paper made available to the Foundation and expected to be published, Santilli introduced his *hypermagnecules*, namely, nonvalence bonds primarily due to opposing magnetic (and electric) polarizations, each bond being multivalued.

Santilli *hyperliquid* is, therefore, composed by hypermolecules under hypermagnecular bonds by achieving in this way one of the most complex structures known to the authors, not only for mathematical treatment, but also because of the truly unlimited possibilities of interconnections *at a distance*, as manifestly necessary for any serious understanding of the complexities of biological systems.

4.5.E Deciphering the DNA code?

The deciphering of the code contained in a Deoxiribonucleic Acid (DNA) is, by far, the most cryptographic problem facing mankind. Santilli felt repugnance to the idea that a code of such a complexity could be understood with the ordinary numbers 1, 2, 3, ... dating back to pre-biblical times. With the understanding that the achievement of a solution will require centuries of studies, Santilli introduced his multi-valued hypernumbers for the specific intent of initiating quantitative studies on the DNA code.

The main argument is that the association of two atoms in a DNA can produce an entire organ, such as the liver, with an extremely large number of constituents. The association of two atoms A_1 and A_1 in a DNA can be mathematically represented via the *multiplication*. The multiplicity of the results of the original

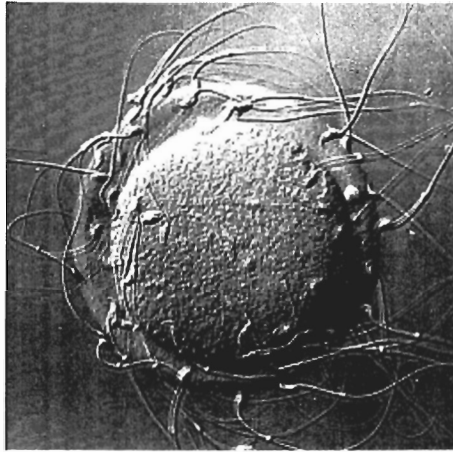

Figure 4.33. The fusion of two gametes to form a zygote and initiate a new life. Santilli argues that the original two individual gametes, generally classified as cells, have in reality an extremely complex structure since they show a specific purpose, movements and action. Hence, their cytoplasm and other components cannot be merely made up of ordinary molecules with quantitatively unknown valence bond and links into a liquid state via quantitatively unknown H-bridges. Hence, he represents each individual genome via his notion of hyperliquid. Additionally, Santilli argues that the two gametes cannot be considered independent one from the other since they seek each other. A representation of this interconnection at a distance is also permitted by the notion of hyperliquid, since the latter allows, in principle, the connection of one cell with all possible cells existing in the universe, of course in a way inversely proportional to the square of the distance, much along the fact that the wavepacket of one electron can be considered to be null only at infinite distance.

association then leads, inevitably, to Santilli hypernumbers in which the product of two elements can give rise to an ordered, but unlimited number of results, e.g.,

$$A_1 \times A_1 = \{1.7684, \int f(r)dr, 745.344, \log(p^{er}), \dots\}. \quad (4.48)$$

The capability by the hypernumbers of at least initiating the deciphering of the DNA code is evident. Despite these evident possibilities, Santilli call published in the historical 1997 monograph [16] as well as in other papers, has remained unanswered by biologists, perhaps due to their limitation to understand Santilli's mathematics. The point is that, without an adequate advanced mathematics, biologists merely have the illusions of advances in their field.

4.5.F *Understanding the DNA structure?*

Santilli never accepted as final the idea that the DNA has a molecular structure, as stated in the best books in the field (see also wikipedia) because excessive simplistic when compared to the complexities of the structure considered.

Therefore, he suggested that *the DNA has a magnecular structure*, namely, it is characterized by atoms that, in part, are under a molecular bond, and in part under a magnecular bond. The hypothesis is strongly supported by the numerous unknown “H-bridges” in the field, with Santilli magnecular bond with a clearly identified attractive force.

Despite a clear advance over rather simplistic models in the literature, Santilli remained dissatisfied with said magnecular structure because basically insufficient to provide the extremely complex inter-relations needed to explain the production of a large organism from a minute helix of atoms.

In this way, he reached one of his most important notions, that that *the DNA has a hypermagnecular structure*, as conceptually indicated in the preceding sections. This essentially means the conception of the DNA as being composed of atoms under hypermolecular bonds that, in turn, are under a hypermagnecular bond.

A rather feverish research is ongoing at a number of corporations in the U.S.A. and abroad. We regret the prohibition to report these studies because of expected disruptions by academic chemists usually aimed at halting the funding to suppress undesired advances.

4.5.G *A future new cure for cancer?*

Self-appointed pseudo-scientist generally dub as “semantic” basic advances without any serious study because beyond their comprehension. This is also the case for Santilli’s discoveries in biology, although by a rapidly decreasing number of academicians. The problem for said pseudo-scientist is that all Santilli discoveries have concrete applications under development by the industry and certainly not by academia, with due exceptions, because of the novelty.

Santilli introduced the notion of magneliquid for the specific intent of initiating the transition from microwave ovens exciting individual molecules of a liquid such as water, to a new generation of equipment that *disrupts the magnecular bond between molecules*. The development of the latter equipment is evidently prohibited by the conventional notion of “H-bridges” due to their pure nomenclature character without quantitative treatment. By comparison magnecular bonds in a liquid can indeed be treated quantitatively. Additionally, all magnetic effects are known to have a temperature at which they disappears (the Curie temperature).

A new equipment that disrupts the magnecular bond between molecules can be attempted in a number of ways, e.g., via microwaves causing the magnecular Curie temperature at the *microscopic level of individual molecular couplings*, which equipment is currently under development by the industry. One of the most important possible application of these advances is a basically new cure for cancer indicated in Figure 4.35.

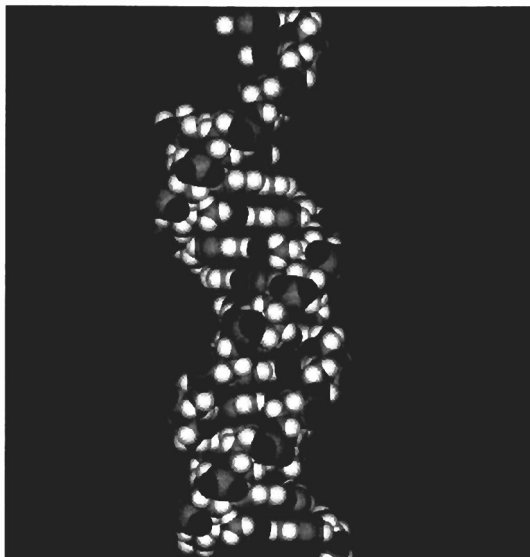

Figure 4.34. Santilli never accepted as final the idea that the DNA is a “molecule” (see wikipedia and advanced references quoted therein) for various reason. To begin, valence electrons can solely bond in pairs under singlet couplings resulting in bosons with null spin (Figure 4.2). A first year graduate student knows that no additional spin 1/2 electron can be credibly bonded to a spin 0 valence electron pair. Therefore, the belief that five hundred million atoms of a DNA could be kept together by valence bonds caused the exiting of science in favor of theology. The next possibility is that a DNA could be a “liquid” since its molecules are admitted in the literature as being bonded by “H-bridges.” However, this alternative hypothesis is faced with gross inconsistencies, e.g., the doubling of cells, the fusion of gametes, and other basic events deviate from the prediction of liquid structures (e.g., via surface tension), again, to such an extent of causing the exiting of science in favor of theology. Santilli’s main stand is that the structure of the DNA is immensely beyond all 20th century knowledge of chemistry. To initiate scientific, that is, quantitative studies, Santilli introduced first the hypothesis that the DNA has a magnecular structure so as to replaced the nomenclature of “H-bridges” with equations and actual attractive forces discussed in Section 4.3E. However, the hypothesis soon turned out to be insufficient, e.g., because of the inability to represent cell interconnections at a distance (Figure 4.33). Consequently, Santilli formulated the broader hypothesis that the DNA has the structure of a hypermagnecule. A rather feverish research is going on at U. S. and foreign companies (rather than academia) along a hierarchy of hypermagnecular structures of increasing complexity, the first one being that bonding together hypermolecules, the second one at the level of chromosomes, and so on. It is regrettable that the current condition of scientific ethics in academic chemistry prevents the disclosure of these industrial studies.

4.5.H Cloonan’s advances in Santilli Magnecules

The cplex-isoelectronic theory is a new theory of pericyclic chemical reactions and aromatic molecules, within the field of organic chemistry, which is based on an expansion of the Robinson electronic theory of organic chemistry. The

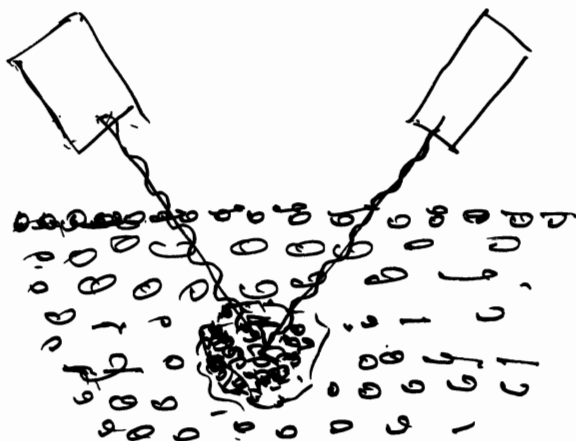

Figure 4.35. Santilli's original hand drawing illustrating a possible future elimination of cancer. The principle is the disruption of the magnetic bond between molecules, whether within a cell, a DNA or other structures depending on the case at hand. In the event the procedure is possible, it is predicted not to require surgery because the achievement of the Curie temperature for the disruption of magnetic bonds in a DNA can be achieved by two microwaves that are individually non-disruptive for human tissues, and are disruptive solely at their intersection, as illustrated in the figure. We regret the inability to report the ongoing industrial research in the field to prevent academic disruptions.

cplex-isoelectronic theory is a qualitative and regularity based theory (see <http://www.cplex-isoelectronic.com>).

The theory was developed as a response to the complexity of chemistry due to the inability of the Schrödinger equation to be solved precisely for H_2 and larger molecules, the resultant use of assumptions and approximations, the formidable and intractable calculations due to the diversity of factors involved and the effect of chaos on complex systems.

The new theory makes different predictions from the present quantum chemical methods and the experimental data, when available, is found to be consistent with these new predictions (see [193]). These new predictions include the existence of suprafacial concerted thermal $[2 + 2]$, $[4 + 4]$, $[6 + 2]$ and $[6 + 6]$ cycloadditions, suprafacial concerted photochemical $[4 + 2]$ and $[6 + 4]$ cycloadditions, stepwise $[2 + 2 + 2]$ cycloadditions of ethyne, diamagnetic ring currents for some cyclic systems with $4np$ electrons, a stepwise pathway for the conrotatory photochemical ring opening of 1,3-cyclohexadiene, a concerted photochemical electrocyclisation for 1,3-cyclohexadiene via disrotatory motion, a concerted suprafacial $[1, 5]$ sigmatropic shift with inversion for norcaradiene, a concerted suprafacial $[1, 3]$ carbon shift with inversion and retention, a concerted suprafacial photochemical $[1, 5]$ hydrogen migration, a concerted photochemical $[3, 3]$ shift, stabilisation of

cyclic $4np$ electron systems by delocalisation and their excess energy is due only to electronic repulsion and strain, the monohomocyclopropenium and cyclopropenyl cations are not "aromatic" (see the above quoted reference).

These findings are also consistent with Santilli's Hadronic Chemistry which predicts more serious limitations with quantum chemistry especially as the explanation provided by the cplex-isoelectronic theory is completely different from the rational provided by quantum theories for pericyclic reactions and aromatic molecules. Nobel prizes have been awarded for these quantum chemical methods; namely the Woodward Hoffmann Conservation of Orbital Symmetry, Fukui's Frontier Molecular Orbital Theory in 1981 and the *ab initio* and DFT methods in 1998. Thus the way is paved for new ideas and theories in organic chemistry and thus in biology. Furthermore it highlights the complexity of chemistry and biology, the limitations of quantitative theories and the fact that quantitative science will never admit final descriptions.

Our research into the magnecular bond has confirmed Santilli's claims that magnecules cannot be detected by infrared (IR) and nuclear magnetic resonance (NMR) spectroscopy as well as highlighting some of the reported anomalies from a chemist's vista. Research is ongoing to explore the magnecular bond by separation of the magnecules and their structural elucidation by gas electron diffraction (see Ref. [192]).



Chapter 5

EXPERIMENTAL VERIFICATIONS IN CLASSICAL PHYSICS, PARTICLE PHYSICS, NUCLEAR PHYSICS, CHEMISTRY, SUPERCONDUCTIVITY, ASTROPHYSICS, ANTIMATTER AND COSMOLOGY

5.1 Introduction

5.1.A *The unreassuring conditions of 20th century particle physics*

Despite historical successes for the structure of the hydrogen atom and other systems, the first half of the 20th century saw numerous authoritative voices of doubt on the final character of special relativity and quantum mechanics, such as: Heisenberg's studies on covering nonlinear theories; Dirac's support for a new theory without divergencies; and others.

During the remaining half of the 20th century, these authoritative voices of doubt were ignored, other sound dissident views were "disqualified" via the abuse of academic authority without technical counter-arguments and, as Santilli puts it, special relativity and quantum mechanics were assumed as being exactly valid for all conceivable conditions existing in the universe, expectedly until the end of time.

This occurrence created an unreassuring condition because all physical theories are known by experts to have limitations. Particularly unreassuring has been the protracted claim of the exact validity of special relativity and quantum mechanics in scattering experiments because of numerous insufficiencies denounced by Animalu and Santilli in their recent memoir [127].

Among said limitations, we recall the manifest irreversibility over time of high energy scatterings compared to the well known reversibility of the very mathematical structure, axioms and physical laws of special relativity and quantum mechanics; the necessary point-like character of all particles under quantum descriptions for which all possible scatterings among charged particles are essentially of Coulomb nature (except for possible decays); and other reasons.

Therefore, the unreassuring condition of the 20th century physics is of such a serious character to cast shadows on the very validity of a number of “experimental results” that, when dealing with relativistic quantum treatments of deep mutual penetration of particles, are called by Santilli “experimental beliefs.”

To stimulate a collegial return to serious scientific values in physics, at his recent invited (and paid) plenary talk at the inauguration ceremony of the new *Research Institute for Hypercomplex Systems in Geometry and Physics* in Moscow, Russia, on May 4–5, 2009 (see [129]), Santilli suggested the conduction of systematic collegial studies on the identification of the following:

I) *CONDITIONS OF EXACT VALIDITY OF SPECIAL RELATIVITY AND QUANTUM MECHANICS*. They are assumed by Santilli as being those of the original conception of the theory by Einstein, Minkowski, Heisenberg, Schrödinger, Dirac and other founders, and are given by *point-like particles and electromagnetic waves propagating in vacuum conceived as empty space*. Hence, special relativity and quantum mechanics are assumed as being exactly valid for the structure of the hydrogen atom, particles in accelerators, and numerous other systems in which the mutual distance of particles is sufficiently big to allow their effective point-like approximation. In this case, we have the sole presence of action-at-a-distance, potential interactions and the systems are entirely represented with the sole knowledge of the Hamiltonian, as well known.

II) *CONDITIONS OF APPROXIMATE VALIDITY OF SPECIAL RELATIVITY AND QUANTUM MECHANICS*. They are assumed by Santilli as being conditions causing the partial or total mutual penetration of the wavepackets and/or charge distribution of particles, as typically the case for mutual distances of the order of 10^{-13} cm = 1 fm, under which we have additional contact interactions that are not representable with a Hamiltonian (variationally nonselfadjoint interactions). In this case, the representation of systems require a second operator besides the Hamiltonian, whose only known invariant selection is given by Santilli isounit. The 20th century physics managed to claim the exact validity of special relativity and quantum mechanics under the latter conditions too via the introduction of completely arbitrary parameters and functions of unknown physical origin, their fit from the experimental data, and then the claim of the exact validity of preferred theories. Santilli has shown that these arbitrary parameters are, in reality, a direct measurement of the *deviations* of special relativity and quantum mechanics from the conditions considered, with truly paradoxical cases, such as that of the Bose-Einstein correlation reviewed below, whose fit of the experimental data requires the *double* of the maximal number of parameters admitted by quantum axioms.

III) *CONDITIONS OF INAPPLICABILITY OF SPECIAL RELATIVITY AND QUANTUM MECHANICS*. They are given by conditions under which the theories permit no quantitative treatment at all despite the throwing into the

equations of all desired arbitrary parameters and functions, as it is the case for the synthesis of the neutron as occurring in stars studied in the next chapter, classical studies of antimatter, mechanics compatible with thermodynamical laws, and others. In this case, Santilli insists that special relativity and quantum mechanics are merely “inapplicable” and cannot be considered as being “violated” because not conceived for the conditions considered.

The most undeniable experimental verifications of hadronic mechanics and its underlying iso-, geno- and hyper relativities are those of Class III studied in detail in the following chapters. The applications industrially most important are those dealing with energy releasing processes, that are in fact strictly irreversible, and they are treated in Chapter 7. Note that the latter require *Santilli Lie-admissible genomechanics* we cannot possibly review to avoid a prohibitive length. Serious scholars are referred to Santilli’s latest and most comprehensive memoir in the field [120].

For a collection of historical papers in irreversibility, we also refer the serious scholar to the volume [152], whose reading should be done by keeping in mind the crucial Theorem 1.1 on the impossibility of eliminating nonpotential irreversible interactions via the reduction of macroscopic systems to elementary constituents, thus identifying the roots of Santilli Lie-admissible genomechanics at the most ultimate level of nature. A technical knowledge of these aspects is important for the serious scholar to dismiss political claims voiced for personal gains, such as the claim that “irreversibility disappears at the level of elementary particles,” a statement disproved by Theorem 1.1.

Again, to prevent an excessive length, in this chapter we shall present a few experimental verifications of Santilli isorelativity and hadronic mechanics restricted to its isotopic branch for conditions of Class II only to show the merely approximate character of special relativity and quantum mechanics compared to the exact validity of the covering isotheries. For a comprehensive and detailed study of the experimental verifications of hadronic mechanics, we refer the serious scholar to the following monograph from which this chapter has been derived [23, 24].

5.1.B *Mutation of particles in interior conditions*

Recall that the intrinsic characteristic of particles, such as mass, charge, spin, magnetic moment, meanlife, etc., parity, are not altered by interactions permitted by special relativity and quantum mechanics. This occurrence originates from the sole admission of action-at-a-distance potential interactions with corresponding definition of *particles* as irreducible unitary representations of the *Galilei symmetry* at the nonrelativistic level, and of the *Lorentz-Poincaré symmetry* at the relativistic level.

The covering isorelativity and hadronic mechanics characterize the broader notion of *isoparticles*, namely, as irreducible isounitary isorepresentations of the

Galilei-Santilli isosymmetry at the nonrelativistic level, and of the *Lorentz-Poincaré-Santilli isosymmetry* at the relativistic level. In turn, the transition from the conventional symmetries for the vacuum to the covering isosymmetries implies that ordinary particles generally experience an alteration of *all* their characteristics, including intrinsic characteristics, Santilli calls *mutation*, in the transition from motion in vacuum at large mutual distances to conditions of mutual penetration. Such a mutation originates from the addition of contact, zero-range nonpotential interactions represented with Santilli isounits under which all characteristics are generally changed, e.g., because of the change of their units.

Santilli's notion of mutation is used in the literature on hadronic mechanics in order to distinguish it from the so-called "deformations" because the latter verify the *Theorems of Catastrophic Inconsistencies of Noncanonical and Nonunitary Theories* studied in Section 3.8. The reader should recall that Santilli's mutations bypass these theorems because they reconstruct canonicity or unitarity on isospaces over isofields, while deformations are afflicted by catastrophic inconsistencies because because of their definition on conventional spaces over conventional fields. In short, the only known invariant representation of nonpotential interactions is that via the isounits, as a result of which the mutation of particle is unavoidable.

It should be noted that the notion of mutation is also referred to in the literature on hadronic mechanics as *isorenormalization*. In this case, "renormalization" is referred to conventional renormalizations for strictly Lagrangian or Hamiltonian theories, while "isorenormalizations" is referred to their image under isotopic lifting in which case Santilli mutations are unavoidable as shown in this and in the following chapters. As Santilli puts it: *"It is generally believed that an electron immersed in the core of a star undergoing gravitational collapse has the same intrinsic characteristics as those nicely observed in our laboratories under sole action-at-a-distance interactions. Besides having no experimental confirmation, such a theological belief has no credibility, not even minimal or remote, since the conditions here referred to imply the acceptance of the perpetual motion within physical media since the electron has to maintain the exact rotational and other conventional symmetries."*

The notion of mutation was first introduced by Santilli in 1967 at the algebraic level as part of his Ph.D. thesis via the transition from a Lie algebra to a Santilli Lie-admissible algebra [32], then re-examined in 1978 via the addition of the mutation from Lie algebras to Lie-Santilli isoalgebras [43], and finally presented at the particle level also in 1978 via the original proposal to build hadronic mechanics [44], in which mutated electrons (ordinary electron immersed within hyperdense hadronic medium) were called "eletons," although the name of "isoelectrons" subsequently became of general use also because the prefix "iso" is applicable to all particles.

A technical knowledge of the notion of *nonrelativistic isoparticles* requires first a reading of the introductory paper [73] (written by Santilli when visiting the ICTP in Trieste, in 1991 under the last invitation issued by Abdus Salam prior to his death) and then a serious study of *Santilli's isotopies of the Galilei relativity and symmetry* available in the two volumes [9, 10]. A serious knowledge of the notion of *relativistic isoparticle* requires a study of *Santilli's isotopies of special relativity and the Lorentz-Poincaré symmetry* whose best presentation remains that of the following two volumes of 1995 [12, 14] (originally written when Santilli was visiting the JINR in Dubna, Russia, during the period 1992–1995). A serious knowledge of the covering notion of *Lie-admissible genoparticle* for irreversible conditions requires the additional study of the following two volumes [3, 4] (written when Santilli was a member of the Department of Mathematics of Harvard University under DOE support, although the first volume carries his affiliation at the Lyman Laboratory of Physics of Harvard University).

5.1.C *Mutation of spacetime caused by physical media*

The fundamental hypothesis underlying Santilli isorelativity and hadronic mechanics is that *physical media, whether characterized by matter or light, alter the very structure of the Minkowskian spacetime of the vacuum*. The applicability of isorelativity then follows from the direct universality of the Minkowski-Santilli isospacetime for all possible line elements with signature $(+, +, +, -)$, and its related fundamental Lorentz-Poincaré-Santilli isosymmetry. The unique applicability of hadronic mechanics follows from unambiguous maps to operator formulations.

The first and most compelling experimental evidence on the mutation of spacetime is that studied in the next section on the *local variation of the speed of light within physical media*. In fact, it is easy to prove that no variation of the speed of light is possible without an alteration of spacetime itself called by Santilli a spacetime mutation.

It should be recalled that the reconstruction of a universal symmetry for a mutated spacetime requires an alteration of the very “units” of both, space and time. The mutation of space units is necessary to reconstruct, e.g., the rotational symmetry for all possible deformations of the sphere, while the mutation of the unit of time is necessary, e.g., to represent the deviations from the conventional time dilation for an electromagnetic wave propagating within a physical medium (see Section 3.10).

For the case of particles, we have a similar situation. An isolated electron in vacuum, being dimensionless, can be safely assumed to evolve according to our own time with unit $I = 1$ sec. However, when the same electron is immersed within a hyperdense medium, such as in the core of a star or in the interior of a proton as needed for the neutron synthesis, the same electron evolves according

to an intrinsic time different than our own whose isounit can be numerically identified from experimental data, as we shall see.

Note that the “price to pay” for the insistence in maintaining our units of space and time under interior conditions is the breaking of basic spacetime symmetries since, as established by the Lie-Santilli isothory, the latter are reconstructed as exact at the isotopic level only under isounits that are numerically the inverse of the alteration of conventional spacetime (Section 3.10).

Alternatively the assumption of the conventional spacetime within physical media implies that an electron in the core of a collapsing star is *identical* to an isolated electron in vacuum, a clearly unpalatable expectation because the electron has a wavepacket that must be deformed when immersed within a hyperdense medium. It should be noted that the above mutations have a fundamental role in predicting basically new clean energies (see Chapter 7) that are unthinkable for special relativity and quantum mechanics precisely in view of their unverified assumption of their exact character within physical media.

The best and most technical presentation on the mutation of spacetime remains that available in Santilli’s 1995 monographs *Elements of Hadronic Mechanics* quoted in the preceding section. For a recent comprehensive presentation one may study the five volumes [20–24].

5.2 Experimental Verifications in Classical and Particle Physics

5.2.A Experimental verification of the mutation of magnetic moments

Classical verification. The most visible and convincing experimental verification of the mutation of the intrinsic characteristics of elementary and composite particles is the *lack of existence in nature of perfect rigidity*, implying the necessary *deformability* of the shape of a charged and spinning particle that, in turn, causes the necessary alteration of the intrinsic magnetic moment as established at the classical level. When *one* mutation is established, the mutation, in general, of spin, rest energy, charge, meanlife, parity, and other intrinsic characteristics follows via simple compatibility arguments, or via the use of the Lorentz-Poincaré-Santilli isotransforms.

Santilli’s mutation of particles is rendered inevitable by the following evidence. In view of its very mathematical structure and axioms, quantum mechanics can solely represent particles as *dimensionless points*, in which case no mutation is conceptually or technically possible. By comparison, hadronic mechanics characterizes particles as *extended*, in which case mutations are unavoidable due to the lack of perfect rigidity in nature.

We can say that the notion of mutation did not exist in 20th century mainstream physics because nonrelativistic and relativistic quantum mechanics and

their underlying spacetime symmetries are irreconcilably incompatible with deformations occurring in the physical reality. By comparison, deformations are readily represented by hadronic mechanics thanks to Santilli's isorotational symmetry that was build precisely for that scope while reconstructing the exact rotational symmetry on isospaces over isofields (Section 3.10).

In closing, we should remember that the classical counterpart of hadronic mechanics, known as the *Hamilton-Santilli iso-, geno- and hyper-mechanics*, have been proved to be "directly universal" in classical physics, that is, representing all possible discrete classical systems (universality) in the coordinate of the experimenter (direct universality), thus having incontrovertible experimental verifications in classical physics. As a matter of fact, serious experts in hadronic mechanics know that these classical verifications are the very foundation of the new operator theory.

Additionally, it should be recalled that said new mechanics are the *only known* capable of representing non-Hamiltonian systems with an action principle, as well as representing said systems in their actual shape, dimension and density. As a matter of fact, the representation via a variational principle is the very foundation for the operator treatment of nonpotential forces. As an illustration, the irreversible Hamilton-Santilli genomechanics is the *only known mechanics* characterizing via the optimal control theory the shape of the wing of an airplane under the resistive force caused by motion in our atmosphere. Following such a so novel a verification impossible with conventional mathematics and mechanics, there seems no point in providing additional verifications in classical physics.

Rauch's interferometric experiment on the neutron spinorial symmetry. The first direct experimental measurement of the deformability of the intrinsic magnetic moments of neutrons was announced by H. Rauch [144] during *Third Workshop on Lie-Admissible Formulations* held at Harvard University in 1981, see the Proceedings [49–51].

The measurements were conducted via a potentially historical neutron interferometric test of the 4π -spinorial symmetry of neutrons as presented in various papers of the time, such as [139–141, 143].

Various calculations for a thermal neutron beam exposed to the intense fields in the vicinity of heavy nuclei, as it is the case for Rauch's experiment (see below) were done by G. Eder at the same 1981 meeting [145, 146]. Eder's conclusion is that strong nuclear forces do not imply an appreciable effect due to the very small sectional area of their influence, while nuclear electric and magnetic fields do imply a measurable effect of the order of 1%, that is precisely the amount indicated by Rauch and his collaborators.

In the experiment, a thermal neutron beam is first coherently split by a perfect crystal and then passes through the gap of an electromagnet in one (or both) branches. The beam is then coherently recombined by the perfect crystal as

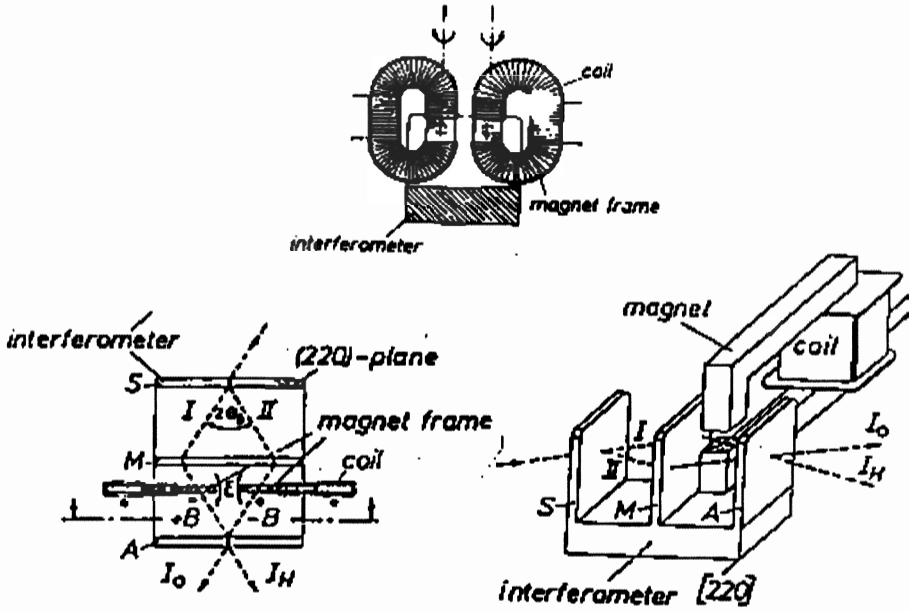

Figure 5.1. A view of Rauch's neutron interferometric experiment on the mutation of the intrinsic magnetic moment of neutrons under very intense external electric and magnetic nuclear fields.

shown in Figure 5.1. The experimenters calibrated the field of the electromagnet to the value 7,496 G to achieve exactly two spin flips, i.e., a rotation of $4\pi = 720^\circ$, as predicted by the exact $SU(2)$ -spin symmetry for the conventional value of the neutron magnetic moment in vacuum

$$m_{\text{neutron}} = -1.913148 \pm 0.000066 m_N. \quad (5.1)$$

When the neutron beam travels in empty space (namely the electromagnet gap is empty), the experimenters confirmed the exact occurrence of the 4π symmetry, thus providing a beautiful verification of quantum mechanics in the conditions under which it is applicable, that is, when neutrons can be all well approximated as massive points.

However, in order to avoid stray fields at the gap borders, the experimenters filled up the electromagnet gap with Mu-metal sheets. This essentially provided a test of the spinorial symmetry of neutrons under the intense electric and magnetic fields in the vicinity of Mu metal nuclei.

In all tests, Rauch and his collaborators *did not find the expected angle of $4\pi = 720^\circ$, but found instead an angle of spin-flip whose median value is consistently smaller than 720°* , an effect that has been called by Santilli *angle slow down effect*. Rauch's best available experimental values are given in his above quoted

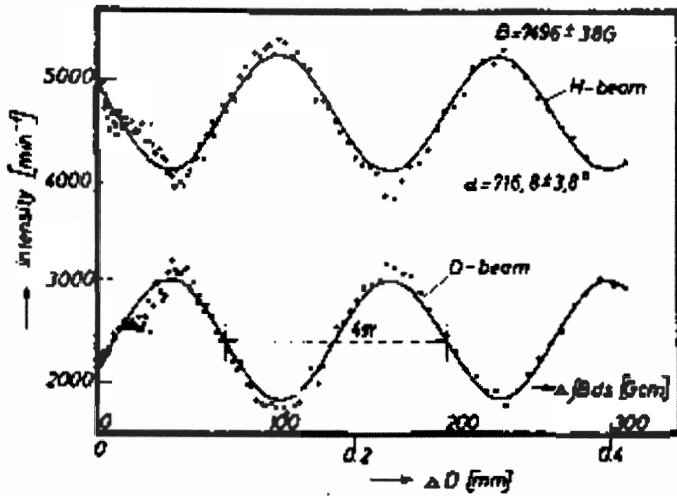

Figure 5.2. The plot of experimental data on the coherent recombination of the split neutron beams in Rauch's 4π neutron interferometric experiments of Figure 5.1. Note the loss of the sinusoidal character of the plot that, alone, establishes a deviation from the exact $SU(2)$ -spin symmetry.

papers by

$$\alpha = 715.87^\circ \pm 3.8^\circ, \tag{5.2}$$

$$\alpha_{\max} = 719.67^\circ, \quad \alpha_{\min} = 712.07^\circ. \tag{5.3}$$

The above measurements do not contain the exact angle 720° , thus providing the first known experimental evidence of the breaking of the $SU(2)$ -spin symmetry in particle physics.

Needless to say, the experiment is not final and must be repeated until the deviation is at least three times the error. By remembering that measurements (5.2) date back to 1978 (see later on for comments), these improvements can be done nowadays in a variety of ways, such as conducting the tests for a large multiple of 4π that would be resolutory, provided that the experimenters fill up the electromagnet gap with Mu-metal sheets or other heavy element (in which absence the tests would have no relevance for the test of mutation due to the weakness of nuclear fields).

Despite this unsettled aspect, Rauch measurements (5.2) are plausible indeed. In fact, they are confirmed by various deviation from quantum mechanical values of total nuclear magnetic moments (see Section 5.3), not to mention numerous theoretical works. Also, as recalled earlier, perfectly rigid bodies do not exist in the physical reality. Therefore, the amount of mutation for given external nuclear fields is certainly open to experimental resolutions, but its existence is beyond credible doubt since its denial implies the belief of perfect rigidity.

Also, the possible recovering of the full 720° angle *is not* sufficient to claim full confirmation of quantum mechanics in the conditions herein considered because there are several other aspects that have to be obtained. One of them is the sinusoidal character of the curve on the coherent recombination of the two split neutron beams. The experimental data shown in Figure 5.2 establish a clear loss of such a sinusoidal character in an amount that is indeed a multiple of the error. On strict scientific grounds, this is sufficient, alone, to provide experimental evidence of mutation of the intrinsic magnetic moment of neutrons.

It should be indicated that, to our best knowledge, Rauch's experiment has never been duplicated since its conduction in the mid 1970s along the lines reported above. More specifically, numerous neutron interferometric experiments have been evidently conducted since that time, but all of them either with the neutron beam moving in vacuum or under a splitting of the beam into opposite contributions yielding no mutation of the neutron magnetic moment. The authors would appreciate any indication of actual neutron interferometric experiments conceived and realized in such a way to *maximize* (rather than minimize or avoid) the exposure of the neutron beam to intense nuclear fields without any splitting into opposing contributions or other manipulations.

Santilli's representation of Rauch's interferometric measurements.

The first quantitative representation of Rauch's measurements (5.2) was reached by Santilli at the *Third Workshop on Lie-admissible Formulations*, of 1981, in the memoir [47] then re-elaborated in the following 1989 paper [61]. Santilli reviewed his representation of Rauch's experiment during his visit of the ICTP in Trieste, Italy in 1991 [65]. The study was then finalized in 1993 when Santilli was visiting the *Joint Institute for Nuclear Research*, Dubna, Russia, Communication of the JINR no. E4-93-352 (1993), with subsequent printed version [90] that is adopted in this section. A recent comprehensive treatment is available in Santilli's monograph [23].

Rauch's experiment deals with the $SU(2)$ -spin symmetry of the neutron when propagating within a physical medium characterized by very intense fields. Since the neutron has spin $1/2$, the representation of the data requires the *Dirac-Santilli isoequation* outlined in Section 3.11Q whose technical knowledge is assumed to prevent venturing vacuous pseudo-judgments.

When the gap of the electromagnet is empty of matter (here assumed to be the vacuum), the neutrons cannot experience any mutation (see the l.h.s of Figure 5.3), and the predictions of quantum mechanics are exact.

However, when the gap of the electromagnet is filled up with dense Mu-metal sheets, neutrons experience a deformation of their charge distribution that, in turn, implies a necessary alteration of their intrinsic magnetic moment, as requested by the electrodynamics of charged, spinning and deformed spheres. Note in this case that *the mutation of the intrinsic magnetic moment occurs without*

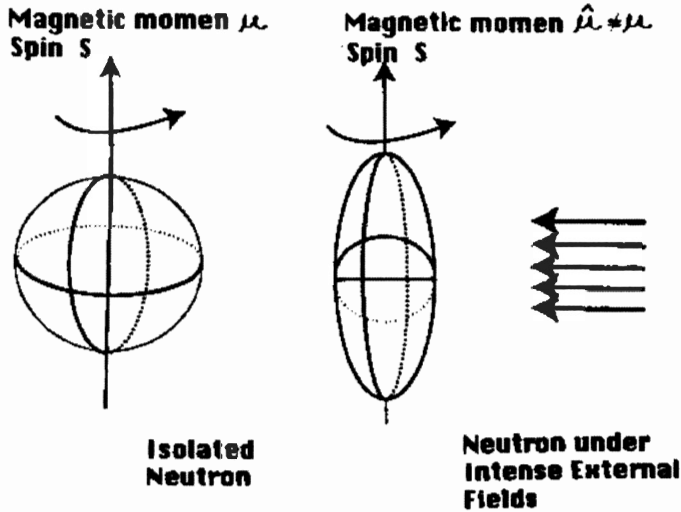

Figure 5.3. The elementary physical interpretation of Rauch’s measurements of Figures 5.1 and 5.2 via a deformation of the charge distribution of neutron of the order of 1%. Note that the deformation must be such as to provide an oblate spheroidal ellipsoid as a condition to represent the “angle slow down effect,” since only such oblate deformation implies a decrease of the intrinsic magnetic moment. Note also that the spin 1/2 of the neutron is not mutated in Rauch’s experiment due to the external long range nature of the electric and magnetic fields acting on the neutron and the absence of contact interactions. The preservation of the spin 1/2 implies that quantitative treatments can be obtained via nonunitary transforms of conventional relativistic treatments, technically expressed by the fact that the irreducible representation of the Lorentz-Poincaré-Santilli isosymmetry are regular (the “exceptional representations” implying an alteration of the spin that cannot be obtained via such a simple map).

mutating the spin 1/2 of the neutron, evidently in view of the long range character of the acting forces.

The fact that the measured angle is consistently *smaller* than that expected (“angle slow down effect”) implies that the intrinsic magnetic moment of the neutron is *decreased* in the considered conditions.

The achievement of a numerical, exact and invariant representation of experimental data (5.2) via relativistic hadronic mechanics is also elementary. Since the neutron is a spinning particle, it is natural to assume that the only possible mutation is that of the charge distribution of the neutron from its spherical shape (necessary for quantum mechanics) to a spheroidal ellipsoid with semiaxes

$$b_1^{-2} = b_2^{-2} \neq b_3^{-2}. \tag{5.4}$$

The ellipsoid will then be a prolate or oblate depending, respectively, on whether

$$b_3^{-2} > b_1^{-2} = b_2^{-2}, \tag{5.5}$$

$$b_3^{-2} < b_1^{-2} = b_2^{-2}. \quad (5.6)$$

Rauch measured a deviation from the $SU(2)$ -spin transformation in the angle α of the spin precession along the third axis. Such a transformation is best represented via Dirac's equation according to the well known law

$$y' = R(\alpha) \times y = (e^{i\gamma_1 \times \gamma_2 \times \alpha/2}) \times y, \quad (5.7)$$

where the γ_s are the conventional Dirac gamma matrices.

The use of Dirac-Santilli isoequations and related isotopic $SU(2)$ -spin symmetry of Section 3.11Q then implies the applicability of the following isolaw

$$\hat{y}' = \hat{R}(\alpha) \times \hat{y} = (e^{i\hat{\gamma}_1 \times \hat{\gamma}_2 \times \hat{\alpha}/2}) \times \hat{y} = (e^{ib_1 \times \gamma_1 \times b_2 \times \gamma_2 \times \alpha/2}) \times \hat{y}. \quad (5.8)$$

By using the Minkowski-Santilli isometric expressed via the b -characteristic quantity, and the explicit form of the Dirac-Santilli isogamma matrices, Santilli obtains the expression

$$\hat{\alpha} = b_1 \times b_2 \times \alpha_{715.87^\circ} = 720^\circ, \quad (5.9)$$

where the exact value of 4π for the isoangle $\hat{\alpha}$ should be expected by experts in isotopies. In fact, all isotopies reconstruct as exact on isospace over isofields conventionally broken symmetries. In this case, the reconstruction of the exact $SU(2)$ -spin symmetry requires that the isoangle be equal to the exact value 4π . In this case, the deviation occurs only in the *projection* of the isothory in our conventional spacetime, exactly as realized in Eq. (5.7).

The above expression immediately provides the first numerical values of the b -characteristic quantities

$$b_1 = b_2 = 1.003, \quad (5.10)$$

$$b_1^{-2} = b_2^{-2} = 0.994. \quad (5.11)$$

Next, the mutation here considered cannot possibly change the density of the hyperdense medium inside the neutron, namely, the mutation must be *volume preserving*. By assuming that the original sphere has a radius normalized to one, this condition implies that

$$b_1^{-2} \times b_2^{-2} \times b_3^{-2} = 1, \quad (5.12)$$

from which we obtain the numerical value of third characteristic quantity

$$b_3^{-2} = 1.002, \quad (5.13)$$

$$b_3 = 0.994, \quad (5.14)$$

namely, *relativistic hadronic mechanics characterizes an oblate spheroidal deformation, with a consequential decrease of the intrinsic magnetic moment, precisely as needed to represent the experimental data.*

To achieve a numerical value of the mutated intrinsic magnetic moment \hat{m} Santilli assume that in first approximation

$$\hat{m}/m = 715.87^\circ/720^\circ. \quad (5.15)$$

But, the Dirac-Santilli isoequation of Section 3.11Q implies the following ration between mutated and conventional magnetic moments

$$\hat{m} = m \times b_3/b_4. \quad (5.16)$$

Santilli reaches in this way the numerical value

$$b_3/b_4 = 715.87/720, \quad (5.17)$$

$$b_4 = 720 \times 0.994/715.87 = 1.000, \quad (5.18)$$

namely, the density of the thermal neutron beam is insufficient to affect the maximal causal speed, that remains the speed in vacuum (Isoaxiom I). The numerical value of the *mutated intrinsic magnetic moment* is then given, in average, by

$$\hat{m} = m \times b_3 = -1.902 m_N, \quad (5.19)$$

namely, *the mutation of the intrinsic magnetic moment in Rauch's experiment is confirmed by the Dirac-Santilli isoequations as being of the order of 1%.*

This completes the *Santilli's numerical, exact and invariant representation of Rauch's experimental data on the 4π neutron interferometric experiment via relativistic hadronic mechanics, representation that is manifestly impossible for quantum mechanics.*

In summary, relativistic hadronic mechanics permits a direct, numerical, exact and invariant representation of:

1) The actual, extended, nonspherical and deformable charge distributions of neutrons and their density via the basic isounit

$$\hat{I} = \text{Diag.}(b_1^{-2}, b_2^{-2}, b_3^{-2}, b_4^{-2}) > 0, \quad (5.20)$$

where b_1^{-2} , b_2^{-2} , b_3^{-2} represent the *semiaxes* of the spheroidal ellipsoid and b_4^{-2} geometrizes the *density* of the medium in the interior of the neutron here having the value 1 from the preservation of the speed of light in vacuum within the Mu-metal sheets;

2) All possible deformations of these shapes via a dependence of the isounit, e.g., on the intensity of the external electric and magnetic fields originating from the nuclei of the Mu-metal nuclei;

3) The "angle slow-down effect," namely, the systematic decrease of the angle of precession due to a decrease of the intrinsic magnetic moment for the physical conditions considered;

4) The necessarily oblate mutation/deformation of the charge distribution of the neutron to represent said angle slow down effect;

5) All the above exact numerical representations are obtained by *reconstructing the exact $SU(2)$ -spin symmetry on isospaces over isofield*, while the same symmetry remains broken in conventional treatments.

In closing, the authors feels a duty to recall rather extreme political interferences by the academic establishment against the finalization of Rauch's fundamental experiment, in documented knowledge of its paramount importance for the prediction and treatment of new clean energies so much needed by mankind (Chapter 9). In fact, Rauch's measurements reported in this section date back to 1978. Following their presentation at the above quoted meeting of 1981, Rauch and his associates were prohibited to continue the measurements at their original laboratory in Grenoble, France, under the conditions herein considered (with the electromagnet gap filled up with heavy metals).

The unreassuring character of the 20th century physics is fully identified by the fact that, despite the passing of some 30 years, this fundamental aspects of scientific knowledge (the exact or broken character of the $SU(2)$ -spin symmetry under external nuclear fields) remains fundamentally unsolved. In fact, all repetitions of Rauch's experiment occurred since 1978 known to the authors were carefully conceived and conducted such to have the thermal neutron beam move in vacuum, the expected deviation in one branch compensated by that of the other branch, or different settings under which the verification of quantum mechanics is unquestionable (the authors would appreciate the indication of true experimental resolutions not quoted here).

Due to the societal implications of the case, Santilli felt obliged to report the organized obstructions against the experimental resolution of the issue in the 1984 book [5] and in the related 1,315 pages of documentation dated 1985 [6-8].

In view of the above, Santilli's deep conviction is that, without a control of scientific ethics in mainstream physics, no truly basic advance for the much needed new clean energies can be effectively achieved due to obstructions, discreditations and other disruptive actions by organized interests on pre-established doctrines under abused academic credibility.

5.2.B *Experimental verification with the meanlives of unstable hadrons*

A direct experimental verification of the validity of Santilli isorelativity and its underlying isogeometry and Lorentz-Poincaré-Santilli isosymmetry (Sections 3.10 and 3.11) in the interior of hadrons is provided by the *anomalous behavior of the meanlife of unstable hadrons with speed*. In fact, according to current experimental data reviewed below, such a behavior:

1) is at variance with the behavior predicted by special relativity,

$$t = t_0 \times \gamma, \quad (5.21)$$

$$\gamma = 1/(1 - \beta^2)^{1/2}, \quad \beta = v_k/c, \quad k = 1, 2, 3, \quad (5.22)$$

where c is the speed of light in vacuum;

2) confirms the behavior predicted by Santilli isorelativity, see Isoaxiom III, Eq. (3.95),

$$t = t_0 \times \hat{\gamma}, \quad (5.23)$$

$$\hat{\gamma} = 1/(1 - \hat{\beta}^2)^{1/2}, \quad \hat{\beta}^2 = v_k \times b_k^2 \times v_k/c \times b_4^2 \times c; \quad (5.24)$$

3) constitutes an indirect verification of the iso-Doppler law, see Isoaxiom IV, Eq. (3.98).

Recall that the center-of-mass behavior of a particle in an accelerator must obey the laws of special relativity (because the particle moves in vacuum under external electromagnetic interactions). Yet, nonlocal interactions are known to imply deviations from special relativity laws. The issue is therefore *how nonlocal effects in the interior of hadrons can manifest themselves in their exterior behavior in a particle accelerator*.

Blokhintsev and his school at the JINR in Dubna pioneered in paper [136] the hypothesis that such nonlocal internal effects can manifest themselves via departures from the Minkowskian behavior of the meanlife of unstable particles with speed, while the center-of-mass trajectory follows Einsteinian theories exactly, and submitted certain generalized time-dilation laws. The problem was subsequently studied by several authors, such as [137, 142, 148] and others. This resulted in a variety of generalized time dilation laws. In the 1983 papers [56, 57] Santilli submitted his isotopies of the special relativity with underlying isotopies of the Minkowskian spacetimes and the Lorentz-Poincaré symmetry as a form of geometrization of the physical medium in the interior of hadrons with isotopic law (5.23). The latter law was subsequently proved by Aringazin [156] as being “directly universal,” i.e., including all possible generalizations of the time dilation law via different expansions in terms of different parameters and with different truncations (“universality”) in the fixed reference frame of the experimenter (“direct universality”). A recent comprehensive treatment is available in Santilli’s monograph [23].

The covering character of Santilli isorelativity now acquires its full experimental significance. Prior to the unified isotopic laws, experimenters had to test a considerable variety of different time dilation laws without having any mean for a possible selection due to unavoidable approximations. With Santilli universal isolaws these problems are eliminated and the tests can be restricted to the unifying law (5.18).

Preceding generalized time dilation laws left basically unsolved the problem of their compatibility with the Einsteinian center-of-mass behavior, thus remaining unsettled even in the event of final experimental verifications. By comparison, the Lorentz-Poincaré-Santilli isosymmetry has been constructed for the purpose

of yielding conventional center-of-mass trajectories, a feature achieved by preserving all ten Poincaré generators and related conserved quantities and isotopically lifting instead their Lie algebra into the Lie-Santilli isoproduct

$$[A, \hat{B}] = A \times T \times B - B \times T \times A, \quad (5.25)$$

where T is fixed integrodifferential (nonlocal) operator for the hadron considered. In this way, the Lorentz-Poincaré-Santilli isosymmetry admits generalized internal laws due to the new interactions represented by the isotopic element T . Therefore, the use of the Lorentz-Poincaré-Santilli isosymmetry assures the compliance of particles with the Einsteinian center-of-mass behavior in particle accelerators, in a way fully compatible with nonlocal internal effects. Note that this is a fundamental point for the historical legacy on the nonlocality of the strong interactions.

The first phenomenological verification of the iso-Minkowskian geometry for the interior of hadrons has been provided by Nielsen and Picek [148] who computed deviations from the Minkowskian geometry inside pions and kaons via standard gauge models in the Higgs sector. These phenomenological studies resulted in a “deformed Minkowski metric” inside pions and kaons of the type

$$\hat{m} = \text{Diag.}[(1 - \alpha/3), (1 - \alpha/3), (1 - \alpha/3), -(1 - \alpha)], \quad (5.26)$$

where α is a constant with numerical values different for different mesons, thus confirming the dependance of the deviations from special relativity on the density of the hadron considered. It is evident that the above generalized metric is a particular case of Santilli isometric (3.57) with numerical values in terms of the characteristic quantities $b = 1/n$ from the data provided by Nielsen and Picek

$$\text{PIONS } \pi^\pm : b_1^2 = b_2^2 = b_3^2 = 1 + 1.2 \times 10^{-3}, \quad b_4^2 = 1 - 3.79 \times 10^{-3}, \quad (5.27)$$

$$\text{KAONS } K^\pm : b_1^2 = b_2^2 = b_3^2 = 1 - 2 \times 10^{-4}, \quad b_4^2 = 1 + 6.1 \times 10^{-4}. \quad (5.28)$$

Note the change in numerical value of the characteristic quantity b_4 in the transition from pions to kaons, which change is necessary for Santilli isorelativity. In fact, *all hadrons have approximately the same size, but different rest energies, thus having different densities. Consequently treatments of different hadrons via Santilli isorelativity requires different characteristic quantities b_4 .*

The first direct experimental verification of the anomalous behavior of the meanlives of unstable hadrons with speed was reached by Aronson et al. [149] who measured a clear anomalous behavior of the meanlife of the K^0 in the energy range 30–100 GeV. Subsequent experiments conducted by Grossman et al. [154] claimed a confirmation the Einsteinian behavior of the meanlife of the particle considered.

Nevertheless, Grossman’s experiment is afflicted by equivocal theoretical and phenomenological assumptions reviewed below, to such an extent to raise doubt

as to whether Grossman's experiment was specifically intended to recover conventional laws (as it has been the case for all neutron interferometric tests following that by Rauch outlined in the preceding section and virtually all experimental data departing from Einsteinian theories).

To begin the appraisal of Grossman's experiment, one should never forget that special relativity is clearly inapplicable within media of low density such as air or water due to insufficiencies beyond credible doubt (Section 3.10). Therefore, the belief without protracted and repeated tests that special relativity is exactly valid in the hyperdense media inside hadrons has no serious credibility, thus casting doubts on excessive theoretical and phenomenological assumptions in the elaboration of raw experimental data by Grossman's team.

Next, deviations from the Einsteinian behavior inside mesons had been previously shown by Nielsen and Picek. Additionally, Grossman's experiment was done for the energy range 100–350 GeV that is *different* than the range 30–100 GeV of Aronson's experiment. Consequently, Grossman's test cannot be claimed as confirming the validity of Einsteinian laws within hadrons on any, even minimally credible scientific ground.

Furthermore, an exact fit of Aronson's anomalous measurements between 30 and 100 GeV was done by Cardone et al. [74] by reaching the numerical values (see Figure 5.5 for the plot)

$$b_1^2 = b_2^2 = b_3^2 = 0.9023 \pm 0.0004, \quad (5.29)$$

$$b_4^2 = 1.003 \pm 0.0021, \quad (5.30)$$

$$b_1 = b_2 = b_3 = 0.949, \quad (5.31)$$

$$b_4 = 1.001. \quad (5.32)$$

In the subsequent paper [75] Cardone et al. (*loc. cit.*) also achieved an exact fit via Santilli's isolaw (5.18) of the two seemingly discordant measurements by Aronson and Grossman for the energy range from 30 to 400 GeV for the interior of the K^0 -particle, resulting in the following *experimental values for the characteristic b-quantities for K^0*

$$b_1^2 = b_2^2 = b_3^2 = 0.909080 \pm 0.0004, \quad (5.33)$$

$$b_4^2 = 1.002 \pm 0.007, \quad (5.34)$$

$$b_1 = b_2 = b_3 = 0.0954, \quad (5.35)$$

$$b_4 = 1.001, \quad (5.36)$$

$$\Delta b_k^2 = 0.007, \quad \Delta b_4^2 = 0.001, \quad (5.37)$$

that are of the same order of magnitude of the values by Nielsen and Picek, Eqs. (5.26), (5.28).

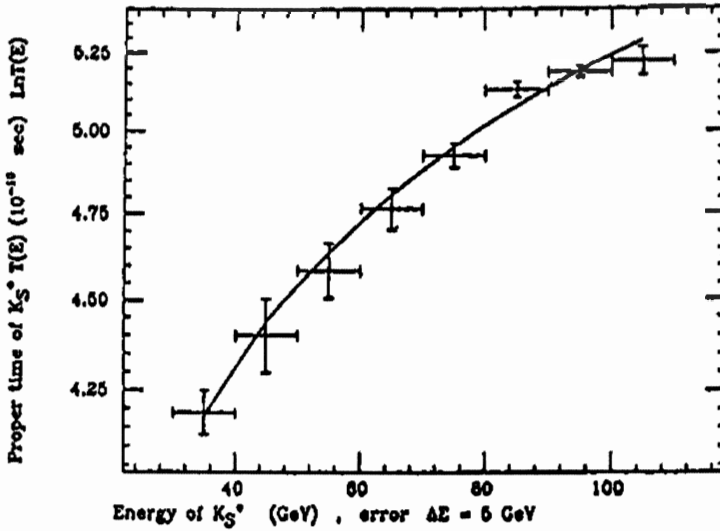

Figure 5.4. The exact plot done by Cardone et al. [75] (loc. cit.) of Aronson's experimental data (loc. cit.) via Santilli's isometric on the anomalous behavior of the meanlife of K^0 with speed in the energy range from 30 to 100 GeV.

Values (5.33)–(5.37) also confirm the prediction of Santilli isorelativity in the range 30–400 GeV according to which the b_4 quantity (being a geometrization of the density of a given hadron) is constant for the particle considered (although varying from hadron to hadron), while the dependence in the velocity rests with the space b_k -quantities.

Note Santilli's reconstruction of the exact Lorentz and Poincaré symmetries at the isotopic level for all anomalous time behavior of meanlives, as proved by Cardone et al. (loc. cit.). By contrast, the quantity α of Eq. (2.3) was called by Nielsen and Picek (loc. cit.) the *Lorentz asymmetry parameter*. In reality the Lorentz symmetry is exactly valid for the deformed metrics when reconstructed with respect to Santilli's isounit

$$\hat{I} = \text{Diag}.\left[(1 - \alpha/3)^{-1}, (1 - \alpha/3)^{-1}, (1 - \alpha/3)^{-1}, -(1 - \alpha)^{-1}\right] \quad (5.38)$$

and related isomathematics. Despite this exact reconstruction, one should note that the conventional Lorentz transformations are necessarily broken for all deformed metrics. Only the Lorentz symmetry remains exact, although realized in a more general way.

Finally, the behavior of the meanlives of unstable hadrons with speed was re-examined by Arestov et al. [105] who focused the attention first on the energy range selection rule that can be applied to re-elaborate the initial data on decays.

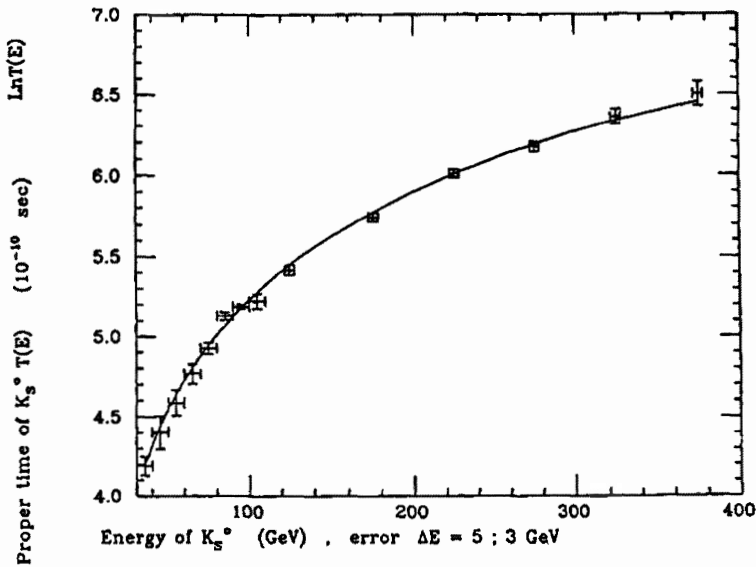

Figure 5.5. The exact plot done by Cardone et al. (loc. cit.) of the seemingly divergent experimental data of both Aronson's and Grossman's experimental data (loc. cit.) via Santilli's isometric in the energy range from 30 to 400 GeV. These plots provided an experimental confirmation of Santilli's isolaw (5.18) in the interior of kaons with numerical values (5.29)–(5.39). Note the clear emergence of a deviation from the Einsteinian law (5.16) despite its (claimed) recovering by Grossman's measurements. The experiments here considered are manifestly fundamental because they establish deviations from the Minkowskian spacetime in the interior of hadrons in favor of Minkowski-Santilli isospacetime due to its direct universality. In turn, the generalization of the basic geometry within hadronic matter has far reaching implications in particle physics, nuclear physics, astrophysics and other fields, including new clean energies. As shown in subsequent chapters, the tests here considered also signal the initiation of a new technology based, for the first time, on strong interactions, an occurrence simply impossible under the exact validity of special relativity in the interior of hadrons.

By taking into account the results as they were done, Arestov et al. performed Monte Carlo simulations of the main features of Grossman's experiment via the use of the same statistics, and reached conclusions dramatically different than those by Grossman et al.

Aronson et al. also provided attention to the parameters used by Grossman in the formula dN/dt for the proper time evolution. The strong correlation of said parameters causes a generally regular dependence of the parameters on entities not present in the formula, such as a number of run offs, etc., apart from the systematic uncertainties. Therefore, the above dependence shadows Grossman's

weak energy dependence that is dominant in this case, as can be seen from the latter large values of the correlation elements.

Additionally, Grossman solved the problem of non-correlated fit by selecting the kaon momenta greater than 100 GeV/c. By means of that energy cut off, Grossman obtained the data sample in which the CP violating terms contribute up to 1.6%. However, it is unrealistic to look for the deviations from the Min-kowskian decay law of the order of 1.6%. More realistic is to test the decay law for the kaons for deviations of the order of 10^{-3} percent, as suggested in the fits by Cardone et al. (loc. cit.).

In fact, the assumption of 1.6% contribution from PC violation in Grossman's data elaboration implies looking for a large energy dependence of their tau function, thus rendering it meaningless to look for more realistic deviations.

The large inefficiency (error) of Grossman's tests occurred because they had not been optimized for the problem at hand. Basically, the experimental design and data selection rules were those of conventional relativistic studies in weak interactions. This implies that Grossman et al. (loc. cit.) assumed special relativity in the data elaboration as shown in Figure 5.6. Their "experimental results" are, therefore, crucially dependent on the assumed theory.

Also, in the selected number of events, both Grossman's and Arestov's fits achieve a good mean value of the hidden parameter determining the energy dependence in the neutral kaon decays. However, the error bars differ strongly, although both results for the same fitting values remain statistically insignificant, even in the selected sample of events. Therefore, the 100% error bar in Arestov's plot illustrates the insufficiency of Grossman's tests quite clearly, since such error permits manipulations of the selection procedure aiming at achieving a predetermined result.

The tests by Grossman's et al (loc. cit.) were finally re-examined by Santilli in the monograph [23], where one can see the possibilities of large differences in the "experimental results" claimed by Grossman et al. (loc. cit.) via even minimal changes in only one out of a variety of parametrizations, cut offs, and other manipulations used to achieve compliance with Einsteinian doctrines, thus voiding Grossman's tests of any conclusive character on all serious scientific grounds.

In conclusion, the confirmation of special relativity within the hyperdense media inside the kaons claimed by Grossman et al. (loc. cit.) has no conception or epistemological credibility; the claim is far from being resolatory in their energy range of 100 to 400 GeV due to an excessive number of equivocal theoretical and phenomenological manipulations of the raw experimental data, besides having insufficient statistics and excessive error; and, even assuming that the claim is eventually confirmed by future tests, the results are inapplicable to Aronson's tests in the different range of 30–100 GeV.

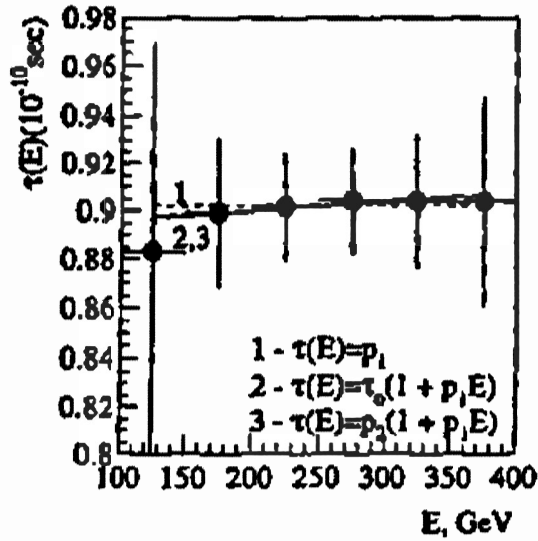

Figure 5.6. A view of three plots made by Arestov et al. (loc. cit.) via the use of Grossman’s statistics of tests (loc. cit.) on the energy dependence of the meanlife of the neutral kaon on the energy showing the dominance of the PC violation selected in Grossman’s tests to such an extent to show an apparent lack of dependence of the meanlife on energy, while the same dependence is clear in the different parametrization selected in the data elaborations by Aronson (loc. cit.) as well as Aronson (loc. cit.). These and numerous other equivocal aspect cast serious shadows on the acceptance for publication of the paper by Grossman’s et al. without a more serious scrutiny.

The exact fit by Cardone et al. (loc. cit.), and Arestov et al. (loc. cit.) of experimental data by Aronson and Grossman constitutes experimental verifications on the following predictions by Santilli isorelativity:

- 1) Photons propagate inside kaons at speeds bigger than that in vacuum,

$$C = c/n_4 = c \times b_4 = 1.001 \times c. \tag{5.39}$$

- 2) The maximal causal speed inside kaons is bigger than the speed of the local photons (as it occurs for water, Section 3.10, Isoaxiom I)

$$V_{\max} = c \times b_4/b_3 = 1.001/0.953 \times c = 1050 \times c. \tag{5.40}$$

- 3) The kaons intrinsic time \hat{t} (isotime) is different than our own time t , and it is given by

$$\hat{t} = t/b_4. \tag{5.41}$$

- 4) The time isounit decreases with the increase of the density, as shown by the data in the transition from pions to kaons, thus predicting that the isotime for gravitational singularities is null.

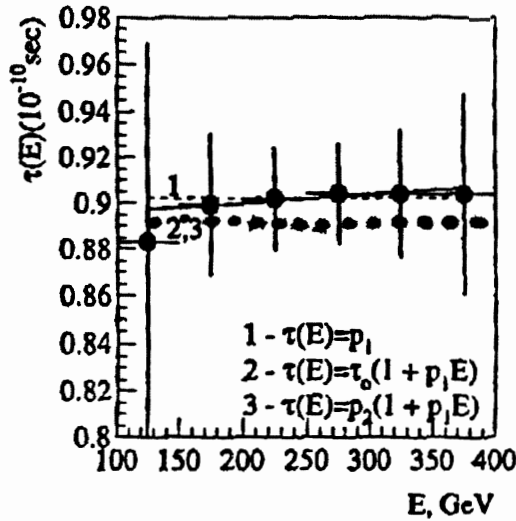

Figure 5.7. A plot of the same data as those of Figure 5.6 run by Santilli in HMMC Volume IV via the use of d parameters different than those used by Aronson et al. showing the extremely unsettled character of claimed “experimental results” when obtained via the use of ad hoc parameters and functions fit from the experimental data within the context of established doctrines. In fact, Santilli’s plot shown in this figure obtained via the use of the same experimental data as those used by Aronson et al. show clear deviations from special relativity expected in any case for an irreversible decay process due to the strict reversibility of the assumed theory.

5) Photons that may be emitted within the interior of hadrons reach the outside vacuum either redshifted or blueshifted depending on the density of the hadron considered (see *Isoaxiom IV*).

5.2.C Experimental verifications with arbitrary local causal speeds

A central feature of relativistic hadronic mechanics is that of predicting maximal causal speed that can be either smaller or bigger than the local speed of light depending on the characteristics of the medium at hand. The experimental evidence establishing the impossibility of reducing light to photons propagating in vacuum, thus at the speed c irrespective of the medium of propagation, is studied later on in this chapter. In this section we provide illustrations of maximal causal speeds smaller and bigger than the speed of light in vacuum.

As it is well known, all action-at-a-distance interactions cannot accelerate matter beyond the speed of light in vacuum, since the mere achievement of the speed of light would require infinite energy. For the case of maximal causal speeds within physical media, the situation is different for several reasons. To begin, the

speed of light is no longer the maximal causal speed within physical media, as it is well established for water where ordinary electrons can travel faster than the local speed of electromagnetic waves. Causality is preserved by Santilli isorelativity precisely because its maximal causal speed in water is bigger than the local speed of light, and turns out to be given by the speed of light in vacuum due to the homogeneity and isotropy of the medium,

$$\text{WATER : } b_4 = b_3, V_{\max, \text{water}} = c \times b_4/b_3 = c. \quad (5.42)$$

In turn, the above values for V_{\max} and $C = c \times b_4$ assure the validity of the isotopic sum of speed of light as well as all Santilli isoaxioms, as one can verify.

Furthermore, motion within physical media occurs under the additional presence of contact interactions that have no potential energy, thus being able to accelerate particles without any local energy consideration, as it is the case of a leaf accelerating in air. When strong interactions are assumed to have a contact, nonpotential component, they can accelerate particles (within hyperdense media) faster than the local speed of light, precisely as it is the case for electrons moving in water at speed bigger than the local speed of light, but always smaller than the maximal causal speed. These ideas were published for the first time by Santilli in the following paper of 1982 [53].

The above hypothesis was studied in the 1980s by various authors but subsequently ignored due to organized interest intent in maintaining the dominance of Einsteinian doctrines for all possible conditions existing in the universe.

Subsequently, G. Nimtz and other experimentalists provided evidence of the propagation of light within certain guides at speeds faster than that in vacuum [161, 180] to such an extent that an entire Beethoven symphony was transmitted at speeds C measured as being bigger than c .

Unfortunately for scientific knowledge, organized interests on Einsteinian doctrines have dismissed these experiments via all sort of theoretical arguments, in full knowledge that *experimental results can solely be dismissed in a credible way via counter-experiments*. As an illustration, by searching under "Superluminal speeds" one can find in Wikipedia (<http://en.wikipedia.org>) a very long list of attempted reinterpretation of speeds bigger than c in a way compatible with Einsteinian doctrines, while carefully avoiding even the quotation, let alone the addressing of Nimtz and other experiments. Most unreassuring is the presentation of numerous extremely ephemeral, thus implausible interpretations compatible with Einsteinian doctrines, while carefully ignoring, at least for completeness, the direct interpretation of the experiments as establishing within physical media indeed speeds bigger than c , thus voiding the entire long presentation of any serious scientific content or credibility. The same presentation at Wikipedia dismisses speeds of light within physical media smaller than that in vacuum via equally esoteric arguments while carefully avoiding the five experimental facts outlined in Figure 6.1.

As we shall see, the validity within a hadron of Santilli iso-Minkowskian geometry and the Lorentz-Poincaré-Santilli isosymmetry is truly fundamental for the scientific study and industrial development of new clean energies. Despite their transparent scientific and societal importance, all major particles laboratories in the U. S. A., Europe and Russia have refused to conduct resolatory experiments on the behavior of the meanlives of unstable particles with speed following formal petitions by Santilli as well as numerous other concerned scientists.

The unreassuring character of the 20th century physics is identified in its full light by the fact that, despite the indicated equivocal aspects well known to experts to qualified as such, the fundamental experimental resolution of the exact or merely approximate validity of Einsteinian doctrines for the interior of hadrons, not only has remained unsolved since Aronson's tests of 1987, but the editors of major physical societies have rejected qualified dissident papers since 1987 on grounds that "Grossman's experiments have confirmed the validity of special relativity in the field," and the repetition of the test has been systematically refused by all particle physics laboratories in the world despite accurate appeals by Santilli and others. Similar unresolved fate occurred since 1992 for the confirmation or denial Nimtz speeds bigger than that of light via *counter-experiments*, rather than equivocal theological manipulations solely damaging their author and their country, rather than conducting any physical research of any value.

Since, on one side, new clean energies are crucially dependent on *deviations* from the exact validity of special relativity inside hadrons (Chapter 9), and since, on the other side, organized interests have systematically prevented or otherwise jeopardized the experimental verification of basic physical laws within hadrons, the only possible conclusion is that, as it was the case for Rauch's fundamental interferometric experiment, *no serious advancement toward new clean energies is possible without concerned people first addressing issues of scientific ethics and accountability in particle physics.*

5.2.D *Experimental verification via the Bose-Einstein correlation*

To complete our few illustrative cases of the experimental verification of hadronic mechanics in particle physics, we present the numerically exact and time invariant representation of the Bose-Einstein correlation from first unadulterated axioms under the reconstruction of the exact Lorentz-Poincaré symmetry on isospace over isofields. This historical result was first achieved by Santilli in 1992 in the memoir [76]. The verification was re-examined by F. Cardone and R. Mignani in the 1996 paper [178]. A comprehensive recent treatment was then provided by Santilli in his 2008 monograph [23] that is herein adopted.

Hadronic mechanics has been built for quantitative treatments of the nonlocal-integral character of the hadronic structure and the strong interactions at large. Therefore, the fundamental verifications of the new mechanics are those directly

dealing with nonlocal interactions. Among various possible experimental verifications of this type, an important verification is that with the Bose-Einstein correlation here referred to the collision of protons and antiproton at high or low energy, their annihilation forming the so-called "fireball," and the subsequent emission of a number of unstable massive particles whose final product is a set of correlated mesons (see Figure 5.8 below).

Evidently, the *approximate* validity of quantum mechanics for the Bose-Einstein correlation is beyond scientific doubt. However, any firm belief on the *exact* character of quantum mechanics for the event here considered is a scientific misconduct, particularly if proffered by experts in the field.

In fact, the Bose-Einstein correlation is necessarily due to nonlocal-integral effects originating in the deep overlapping of the wavepackets of protons and antiprotons. The mathematical foundations of quantum mechanics (such as its topology), let alone its physical laws, are inapplicable for any meaningful representation of said nonlocal interactions (those occurring in a volume that, as such, cannot be consistently reduced to a finite set of isolated points as requested by quantum mechanics). The fundamental quantity needed for the representation of experimental data on the Bose-Einstein correlation, the two-point correlation amplitude (see below), is irreconcilably incompatible with the basic axioms of quantum mechanics when expressed in a form representing the experimental data. To clarify this occurrence, let us recall that the basic quantum mechanical axiom of expectation values of a Hermitean, thus diagonal operator A (observable) solely permits structures of the type

$$C_k = S_{k=1,2,3,\dots} \langle s_k | \times A_{kk} \times | s_k \rangle. \quad (5.43)$$

By comparison, as expected to be known by experts, a quantitative representation of the Bose-Einstein correlation requires non-null cross terms of the type

$$C_{ij} = \langle s_i | \times A \times | s_j \rangle \neq 0, \quad i \neq j, \quad (5.44)$$

that are impossible for the quantum axiom of expectation value for Hermitean, thus observable operators.

For the case of the two-point correlation amplitude, the maximal number of parameters admitted by quantum mechanics is, therefore, *two*, while any representation of experimental data requires *four* parameters of totally unknown physical origin and meaning, called the "chaoticity parameters." In fact, the rigorous application of the unadulterated axioms of relativistic quantum mechanics predicts the following *two-point correlation function*

$$C_2 = N \times (1 + e^{-r^2 \times q^2}), \quad (5.45)$$

where N is a renormalization constant, r is the radius of the fireball and q the relative four-momentum of the proton-antiproton system. However, the above expression is dramatically far from experimental data.

BOSE-EINSTEIN CORRELATION

QUANTUM MECHANICAL APPROXIMATION OF THE CORRELATION

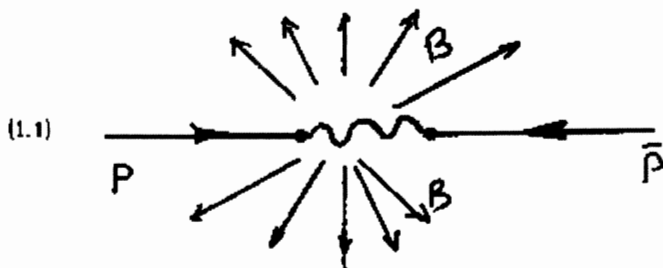

A MORE REALISTIC DESCRIPTION OF THE CORRELATION

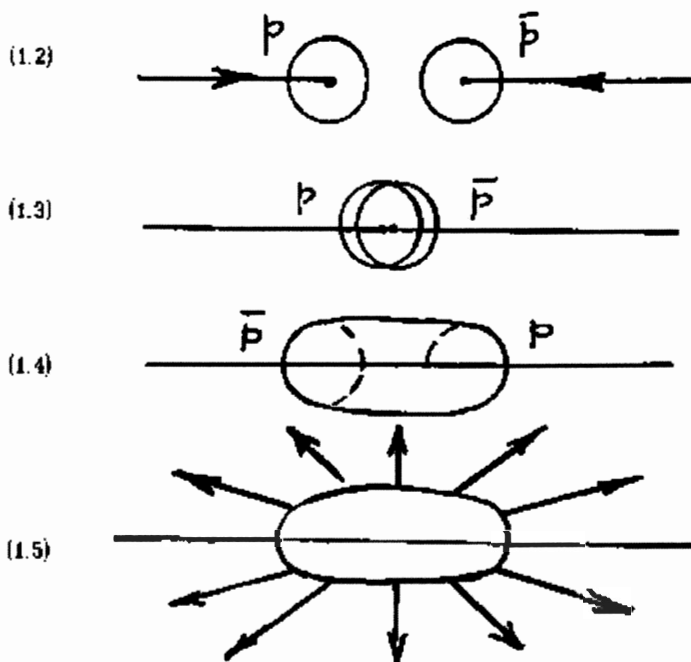

Figure 5.8. A schematic view of the Bose-Einstein correlation originating in proton-antiproton annihilations. The top view depicts the event as permitted by quantum mechanics, that is, with the necessary abstraction of protons and antiprotons as massive points, in which case no correlation is conceptually or technically possible (see the text). The lower views depict the event as described by the covering hadronic mechanics, according to which the proton and the antiproton are represented with their actual, extended, non-spherical and deformable shape. The particles first coalesce, then they annihilate and form the so-called "fireball," namely, a spheroid ellipsoid whose prolate character depends on the energy of the particles. The fireball then decays into numerous unstable hadrons whose final product is given by correlated mesons released in all space directions.

A chain of adulterations of the exact expression (5.45) were then ventured in the literature in order to achieve a fit of experimental data while still claiming exact validity of quantum mechanics. A first adulteration is given by the expression

$$C_2 = N \times (1 + P \times e^{-r^2 \times q^2}), \quad (5.46)$$

where P is an *ad hoc* “chaoticity parameter,” introduced without any physical motivation or origin.

Expression (5.46) also resulted in being excessively far from experimental data. Therefore, additional adulterations became necessary with expression of the type

$$C_2 = N \times (1 + P_1 \times e^{-r_1^2 \times q^2} + P_2 \times e^{-r_2^2 \times q^2} + \dots). \quad (5.47)$$

The latter expression too resulted in being basically insufficient to represent experimental data and, therefore, the chain of adding arbitrary parameters of unknown physical origin or meaning was continued to salvage quantum mechanics, by reaching in this way the indicated need for four chaoticity parameters, while in reality crossing the limits of applicability of quantum mechanics.

It is then clear to ethically sound scholars that, rather than confirming the validity of quantum mechanics as claimed for political reasons, the four chaoticity parameters establish instead the *deviation* of quantum mechanics from the experimental evidence of the Bose-Einstein correlation.

After studying the problem for years, Santilli (loc. cit.) proposed in 1992 the following treatment of the Bose-Einstein correlation via relativistic hadronic mechanics for the following reasons:

i) Relativistic hadronic mechanics has been built precisely for the quantitative treatment of nonlocal-integral interactions occurring in the Bose-Einstein correlation;

ii) The basic axioms of relativistic hadronic mechanics have been built to admit the needed cross terms in the expectation values of Hermitean operators, which cross terms are merely permitted when the isotopic element T is Hermitean but has non-diagonal elements,

$$\hat{C}_{ij} = \langle s_i | \times T_{ik} \times A_{kk} \times T_{kj} \times | s_j \rangle, \quad i, j = 1, 2, \quad i \neq j; \quad (5.48)$$

iii) Relativistic hadronic mechanics reconstructs the exact Lorentz-Poincaré symmetry for the Bose-Einstein correlation because all nonlocal-integral effects are embedded in the generalized unit;

iv) Relativistic hadronic mechanics is the *only* known generalized mechanics outside the class of unitary equivalence of quantum mechanics that achieves *invariance over time*, thus avoiding the catastrophic physical and mathematical inconsistencies of nonunitary theories (Section 3.7);

v) As it was the case for the behavior of the meanlife with speed, relativistic hadronic mechanics is directly universal, thus including as particular cases all possible nonunitary generalizations of quantum mechanics.

Santilli representation of the Bose-Einstein correlation via relativistic hadronic mechanics can be outlined as follows. The new mechanics permits a direct representation (i.e., a representation via the isometric itself) of the actual *shape* of the fireball with the space characteristic quantities b_1^{-2} , b_2^{-2} , b_3^{-2} representing the semiaxes of the spheroid ellipsoid, as well as of the *density* of the fireball via time characteristic quantity b_4^{-2} , resulting in Santilli's isounit, isotopic element and isometric (Section 3.10)

$$\hat{I} = \text{Diag.}(b_1^{-2}, b_2^{-2}, b_3^{-2}, b_4^{-2}) = 1/T > 0, \quad (5.49)$$

$$T = \text{Diag.}(b_1^2, b_2^2, b_3^2, b_4^2), \quad (5.50)$$

$$\hat{m} = T \times m = \text{Diag.}(b_1^2, b_2^2, b_3^2, -b_4^2), \quad (5.51)$$

where $m = \text{Diag.}(1, 1, 1, -1)$ is the conventional Minkowski metric.

The above diagonal expression is insufficient for the proton-antiproton correlation due to the need for nonlocal-integral interactions as well as of the indicated cross terms. Therefore, the complete isominkowskian metric is given by the above expression for \hat{m} multiplied by the following nondiagonal Hermitean matrix

$$\hat{m} = \hat{m} \times C_{ij}, \quad i, j = 1, 2, \quad (5.52)$$

where C_{11} and C_{22} are real valued, $C_{12} = C_{21}$, and the four C 's are given by all possible integrals in the inner product of wavefunction 1 for the proton and 2 for the antiproton (see Santilli, loc. cit., for brevity), thus resulting in the needed four contributions.

The isotopies of the conventional relativistic derivation yield the following *Santilli two-point isocorrelation function*

$$\hat{C}_2 = 1 + (K/3) \times S_{k=1,2,3,4} \hat{m}_{kk} \times e^{-q_t^2/b_k^2}, \quad (5.53)$$

where q_t is the momentum transfer needed to fit experimental data, \hat{m} is expression (5.51) and K has the following form

$$K = b_1^2 + b_2^2 + b_3^2 = 3, \quad (5.54)$$

where the normalization to 3 is requested to admit a consistent relativistic limit.

By using isocorrelation amplitude (5.53), Santilli predicted the following *maximal and minimal values*

$$C_2^{\max} = 1 + 1/3 + 1/3 + 1/3 - 1/3 = 1.67, \quad (5.55)$$

$$C_2^{\min} = 1, \quad (5.56)$$

as well as the following *maximal values for the fourth characteristic quantity (density of the fireball)*

$$1 + K^4/3 + 3 \times K^2 \times b_4^2 = 1.67, \quad (5.57)$$

$$b_4^2 = n_4^{-2} = 2.33, \quad (5.58)$$

$$b_4^{-2} = n_4^2 = 0.429. \quad (5.59)$$

$$b_4 = 1.526, \quad (5.60)$$

$$n_4 = 0.654. \quad (5.61)$$

Therefore, relativistic hadronic mechanics predicts that *the speed of photons inside the Bose-Einstein fireball is bigger than that in vacuum,*

$$c = b_4 \times c_0 = 1.526 \times c_0, \quad (5.62)$$

and that *the intrinsic time of the fireball (isotime) is decreased with respect to our time*

$$\hat{t} = t/b_4 = 0.654 \times t. \quad (5.63)$$

All the above theoretical predictions resulted in being confirmed by the fit of the experimental data subsequently conducted by Cardone and Mignani (loc. cit.) resulting in the following numerical values (see Figure 5.9)

$$b_1 = 0.267 \pm 0.054, \quad b_2 = 0.437 \pm 0.035, \quad b_3 = 1.661, \quad (5.64)$$

$$b_4 = 1.653 \pm 0.015. \quad (5.65)$$

$$b_1^2 = 0.071, \quad b_2^2 = 0.191, \quad b_3^2 = 2.759, \quad (5.66)$$

$$b_4^2 = 2.732, \quad (5.67)$$

$$n_1 = 3.745, \quad n_2 = 2.288, \quad n_3 = 0.602, \quad (5.68)$$

$$n_4 = 0.605, \quad (5.69)$$

$$n_1^2 = 14.025, \quad n_2^2 = 5.235, \quad n_3^2 = 0.602, \quad (5.70)$$

$$n_4^2 = 0.366. \quad (5.71)$$

Note the very elongated character of the fireball established by the experimental values of its semiaxes n_k^2 , $k = 1, 2, 3$. Note also that the density of the fireball, $b_4^2 = 2.732$ is bigger than 1, thus establishing that the speed of photons within the fireball is *bigger* than that in vacuum.

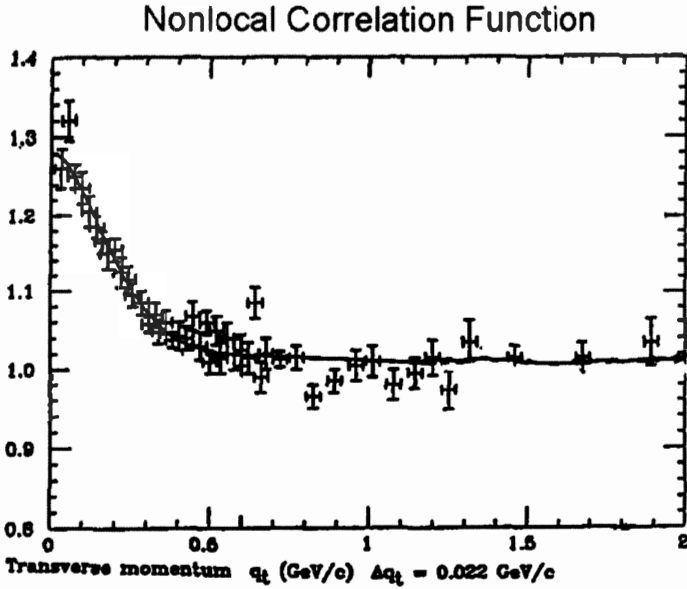

Figure 5.9. A reproduction of the excellent fit of the two-point isocorrelation function with experimental data on the Bose-Einstein correlation at very high energy from the celebrated UA1 experiments at CERN, first published by Santilli in 1991 (*loc. cit.*) and then re-examined by Cardone and Mignani in 1996 (*loc. cit.*). As one can see, the fit is a clear experimental verification of the validity of Santilli isorelativity in the interior of the proton-antiproton fireball. The fit reproduced in this figure may well result in being, in due time, the first experimental evidence on the ultimate nonlocality of the structure of the universe, with consequential needs for a suitable generalizations of contemporary local-differential mathematics, geometries, mechanics and relativities.

5.2.E Characterization of hadronic media

The above fits provide a major experimental verification of the following aspects:

- I) The predictions by relativistic hadronic mechanics are confirmed with an exact fit of the experimental data;
- II) The fits of experimental data confirm the maximal value 1.67 and minimal value 1 of the two-point isocorrelation function;
- III) The experimental fits confirm the theoretical prediction for the value of the density of the proton-antiproton fireball;
- IV) The experimental fits confirm the nonlocal, nonpotential and nonunitary nature of the correlation at the very foundation of hadronic mechanics;
- V) The fits confirm the validity of Santilli isorelativity and related isometric for the interior of the proton-antiproton fireball;

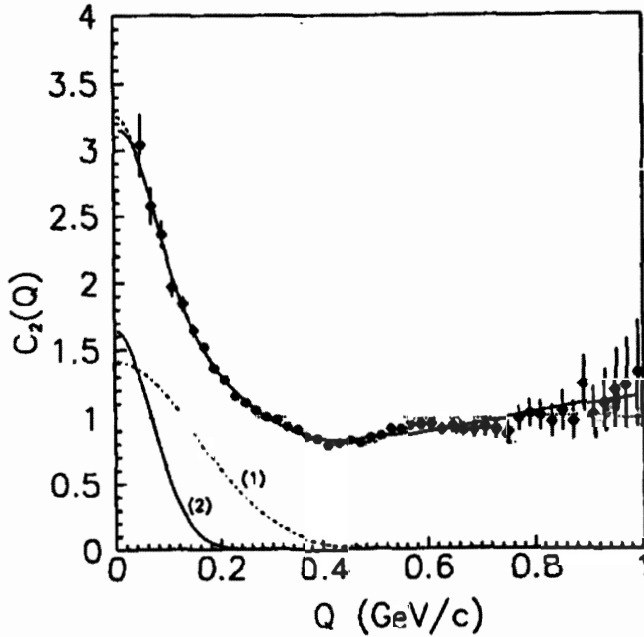

Figure 5.10. Another exact fit of the experimental data on the Bose-Einstein correlation for proton and antiproton annihilation, this time, at low energy. Curves indicated with 1 and 2 represent the fits with quantum models. Their dramatic deviation from experimental data is sufficient to disqualify any claim on the exact validity of quantum mechanics for the Bose-Einstein correlation that, unfortunately, has been rather widespread during the physics of the second half of the 20th century.

VI) The fits confirm the capability by relativistic hadronic mechanics of reconstructing the exact Lorentz-Poincaré symmetry at the isotopic level for the proton-antiproton annihilation;

VII) The fits confirm that the speed of photons within hyperdense hadronic media is *bigger* than their speed in vacuum,

$$C = c/n_4 = c \times b_4 = c \times 1.526; \tag{5.72}$$

and that, from Isoaxiom IV, they are *blueshifted* in their propagation inside the fireball (acquire energy),

$$\hat{\omega} = (1 + \beta \times b_k/b_4)\omega, \tag{5.73}$$

where k is the direction of emission, with consequential *redshift* for propagation within media of light density (loss of energy to the medium), a feature that allowed Santilli to *eliminate dark energy* as we shall see later on in this chapter;

VIII) The fit establish that the time in the interior of the fireball is *slower* than our time

$$\hat{t} = t \times \hat{I}_t = t \times n_4 = t \times 0.654, \quad (5.74)$$

thus yielding a null time for the interior of a gravitational singularity, an important feature for cosmology as we shall see later on in this chapter;

IX) The fits finally confirm Isoaxiom I according to which, for the considered fireball, the energy equivalence of the fireball is *bigger* than that predicted by special relativity,

$$\hat{E} = m \times c^2 \times b_k^2/b_4^2, \quad (5.75)$$

a feature that allowed Santilli to *eliminate dark energy*, as we shall see later on in this chapter.

When the above experimental verifications are joined with those of the preceding sections and those of the following chapters, the validity of Santilli's isorelativity and relativistic hadronic mechanics emerge rather forcefully.

Independently from all the above, the reader should know that the most important single result of this section is that the numerical value of the density of hadronic matter provided by the experimental data on the proton-antiproton fireball has resulted to be crucial for the first quantitative representation of the synthesis of the neutron as occurring in stars from protons and electrons outlined in the next chapter.

5.3 Experimental Verifications in Nuclear Physics

5.3.A *The unreassuring condition of 20th century nuclear physics*

Following the historical achievement of the numerically exact representation of all experimental data on the hydrogen atom, the 20th century nuclear physics has been developed under the condition of achieving full compliance with quantum mechanics. This occurrence has created an unreassuring condition of this important field of scientific knowledge because the dramatic physical differences between atomic and nuclear structures suggest *deviations* from quantum mechanics in the transition from the former to the latter structures, as established by the following insufficiencies identified by Santilli in numerous of his writings:

1) *The Galilean and Lorentz-Poincaré symmetries of atomic structures cannot possibly be exactly valid for nuclear structures* because said symmetries crucially depend on the Keplerian character of the structure with a Keplerian center, while, as Santilli stresses *nuclei do not have nuclei*. The proof of the inapplicability (rather than violation) of the conventional spacetime symmetries for the structure of nuclei can then be done by a first year graduate student (see Figure 5.11).

The absence of a Keplerian structure in nuclei was a primary motivation for Santilli to build his isotopic covering of the Galilei and Lorentz-Poincaré symmetries. In fact, such isotopies are based on the additional presence in interior

structural problems of additional contact, zero-range nonpotential interactions whose primary implication is precisely that of “glueing” all constituents together, thus assuring the absence of a Keplerian nucleus.

Of course, the *approximate* validity of quantum mechanics in nuclear physics is and remains beyond doubt. However, when the basic quantum symmetries are no longer exact, the *lack* of exact character of quantum mechanics is also beyond doubt, the only debatable aspect being the selection of the appropriate generalization.

This is a truly central point of all of Santilli studies, as well as of this presentation, because, as shown in details in Chapter 9, the expected deviations from quantum mechanics, no matter how small, permit the conception and development of basically new nuclear forms of energy that are inconceivable under the current assumption of the exact validity of quantum mechanics in the field.

2) *While quantum mechanics has achieved an exact representation of all features of the hydrogen atom, the same discipline has failed to reach a meaningful representation of the simplest possible nucleus, the deuteron, with embarrassing deviations for heavy nuclei, such as the zirconium.*

In fact, following about one century of failed attempts, quantum mechanics has been unable to represent some of the basic features of the deuteron, such as its spin, stability, rest energy and other basic features (see Chapter 8).

Lacking an exact representation of experimental data from unadulterated first principles, any belief of the exact character of quantum mechanics in nuclear physics is outside the boundaries of serious science.

3) *Quantum mechanics has been unable to provide any explanation of nuclear magnetic moments, as a result of which, the best treatises of 20th century nuclear physics merely list the values of nuclear magnetic moments between minima and maxima (see Figure 5.12).*

It should be stressed that quantum mechanics has been unable to represent the magnetic moment of the simplest possible nucleus, the deuteron, where about 1% remains missing despite all possible relativistic corrections.

The simplest possible interpretation of nuclear magnetic moments is Santilli's deformation of the shape of protons and neutrons under nuclear forces with consequential mutation of their intrinsic magnetic moments, but it could not be adopted by the 20th century mainstream nuclear physics because causing the exiting from the boundary of quantum mechanics.

4) *Quantum mechanics has failed to achieve a full understanding of the nuclear force, despite about one century of attempts.* This is essentially due to the pre-determined intent of rendering the representation compatible with quantum theories, as a result of which the sole admitted forces are of potential type.

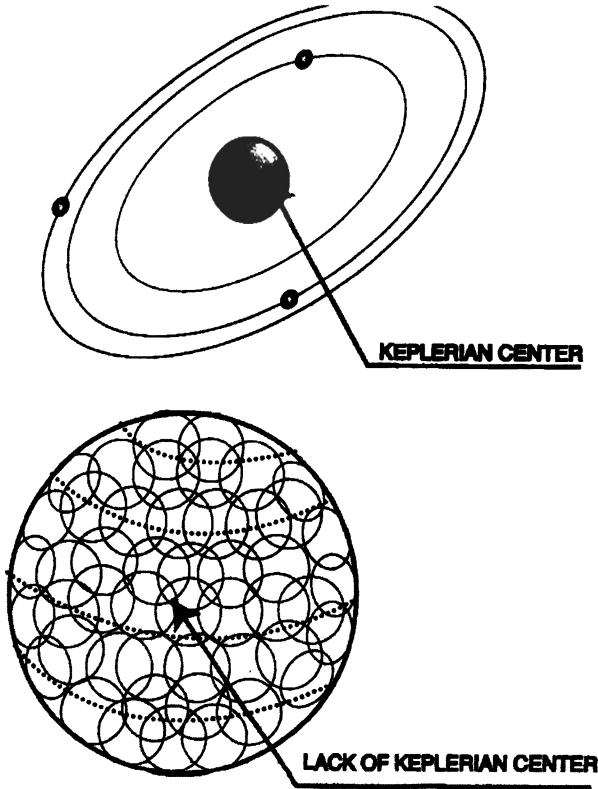

Figure 5.11. A visual evidence of the impossibility for quantum mechanics to be exactly valid in nuclear physics voiced by Santilli in numerous of his writings: the fact that “nuclei do not have nuclei,” thus causing the breaking of the fundamental Galilean and Lorentz-Poincaré symmetries of quantum mechanics (see also Figure 1.2). The impossibility for quantum mechanics as being exact for the nuclear structure is then beyond credible doubt.

In turn, the sole use of a potential has turned nuclear forces into a distressing scientific field, since the addition of about forty potentials in the nuclear force, Eq. (1.5), has failed to achieve any resolution.

It should be noted that the admission of a contact interaction among nuclear constituents, as established by evidence, could not be adopted by 20th century nuclear physics because it would have implied the exiting from the class of unitary equivalence of quantum mechanics, a line of research opposed by 20th century leading nuclear circles around the world.

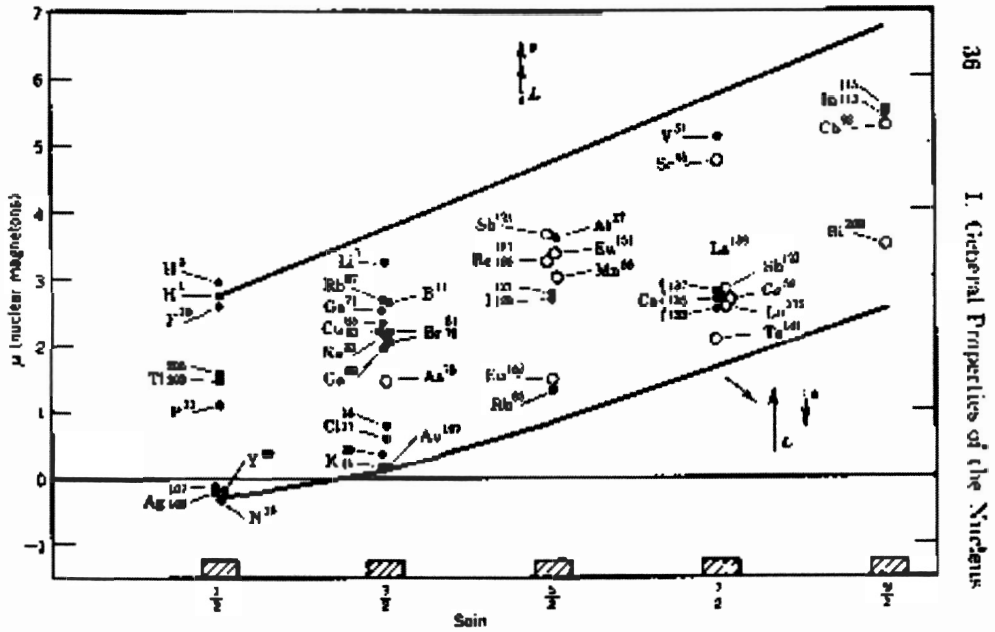

Figure 5.12. Additional evidence of the lack of exact character of quantum mechanics in nuclear physics given by experimental data on nuclear magnetic moments that do not follow quantum predictions, and are instead comprised between certain maximal and minimal values partly reproduced in this figure from known nuclear sources.

5) *Quantum mechanics cannot possibly be exact for nuclear fusions due to the strict reversibility of the former compared to the strict irreversibility of the latter.* One of the best kept secrets in Ph.D. courses in nuclear physics is that the quantum mechanics predicts a finite probability for the “spontaneous” disintegration of a nucleus following its synthesis, Eq. (1.4).

An argument used by mainstream nuclear physics to bypass the above insufficiency is that “quantum mechanics works well for nuclear fissions,” a statement that is indeed correct, as established in any case by the good operation of nuclear power plants based on nuclear fission.

The equivocal aspect, particularly when not identified by experts, is the lack of indication of the dramatic differences between nuclear fissions and fusions as stressed several times by Santilli in his writings, Even though manifestly irreversible, nuclear fissions produce debris that, moving in vacuum, can be well abstracted as being point-like, thus permitting quantum mechanics to provide a good approximation. By contrast, no point-like abstraction of nuclei is possible for any, minimally credible representations of nuclear fusions, in which case the inapplicability of the theory is beyond doubt, as established in any case by over

half a century of failed attempts to achieve industrially valuable “cold” and “hot” fusions (following an overall investment in excess of one billion dollars).

Santilli conceived hadronic mechanics in 1978 and headed its construction as well as verification precisely for the resolution of nuclear insufficiencies 1) to 5) of quantum mechanics. A minimal knowledge of the field can be claimed only following a technical understanding that hadronic mechanics is the *only* covering of quantum mechanics providing a resolution of the above insufficiencies in a way form invariant over time. Santilli’s use of hadronic mechanics in nuclear physics is based on:

I) The termination of the sole use of potentials or Hamiltonians;

II) The sole representation with a Hamiltonian of interactions with an assured at-a-distance character,

$$H = \sum_{k=1,2,\dots,N} \frac{p_k^2}{2 \times m_k} + V(r); \quad (5.76)$$

III) The representation of all remaining interactions, features and effects with isounits of the type

$$\hat{I} = \sum_{k=1,2,\dots,N} \text{Diag.}(b_{1k}^{-2}, b_{2k}^{-2}, b_{3k}^{-2}, b_{4k}^{-2}) \times e^{F(t,r,p,|s),\dots),} \quad (5.77)$$

where the space characteristic quantities $b_{ik}^{-2} = n_{ik}^2$, $i = 1, 2, 3$, permit, for the first time, a direct representation of the actual, nonspherical and deformable *shape* of the charge distribution of nucleons, or of a nucleus as their collection; the time characteristic quantity $b_{4k}^{-2} = n_{4k}^2$ permits, also for the first time, a direct representation of the *density* of nucleons, or of the nucleus; the function F permits, again for the first time, a consistent and time invariant representation of nuclear interactions that are nonlinear in the wavefunction, nonlocal (of integral type) and contact (nonpotential) character; and the hadronic representation is restricted by the condition $\lim_{\hat{I}_r \gg 1} \text{Fermi}$ under which hadronic mechanics recovers quantum mechanics uniquely and identically, as now well known.

The consistency of hadronic mechanics for nuclear structures and their reactions is then assured by various properties hereon assumed to be known, such as: the preservation of Hermiticity under isotopies as a result of which all quantum mechanical observables remain so under hadronic mechanics; the preservation under isotopies of the generators of quantum spacetime symmetries as a result of which all conventional total quantum mechanical conservation laws remain fully valid under treatment by hadronic mechanics; and other features (see Section 3.11).

A general presentation of the specialization of hadronic mechanics for nuclear structures is available from the memoir [109]. Santilli’s quite intriguing *reconstruction of the exact SU(2)-isospin symmetry in nuclear physics* is available from

the paper [107]. The first known time invariant Lie-admissible treatment of irreversible nuclear processes is available from the paper [54], while a comprehensive Lie-admissible treatment of irreversibility is available from the recent memoir [120]. A comprehensive study is available in Santilli's five volumes [20–24].

5.3.B *Experimental verification with nuclear magnetic moments*

The first historical hypothesis for the correct interpretation of the anomalous behavior of nuclear magnetic moments dates back to the time of Fermi, Segre, and others in the 1940's. The hypothesis then propagated to various treatises in nuclear physics in the first half of the 20th century. For instance, in the treatises in nuclear physics by Blatt and Weisskopf (not quoted here because it is excessively known) one can read on page 31: *It is possible that the intrinsic magnetism of a nucleon is different when it is in close proximity to another nucleon.*

The study of this so plausible a hypothesis, was abandoned in the second half of the 20th century when researchers understood that alterations of the intrinsic characteristics of nucleons are strictly prohibited by quantum mechanics, as indicated in Section 5.1.

The reader should be aware that Santilli's hypothesis on the mutation of the intrinsic characteristics of particles was based precisely on the above historical legacy. Following the prior construction and verification of hadronic mechanics, the first known exact representation of nuclear magnetic moments was presented by Santilli at the meeting Deuteron 1993 held at the *Joint Institute for Nuclear Research*, Dubna, Russia, with related paper [83]. The representation was then expanded in the memoir herein adopted [109].

The study is essentially based in the use of the Dirac-Santilli isoequation (Section 3.11Q) that characterizes the isotopy of the conventional quantum mechanical treatment of nuclear magnetic moments. This settings leads to the following *total isonuclear magnetic moments* expressed for simplicity along the third axis

$$\hat{\mu}_{\text{tot}} = \sum_{k=1, 2, \dots, N} (\hat{g}_k^L \hat{L}_{k3} + \hat{g}_k^S \hat{S}_{k3}), \tag{5.78}$$

$$\hat{g}_k^L = g_k^L b_3/b_4, \quad \hat{g}_k^S = g_k^S \times b_3/b_4, \tag{5.79}$$

where L (S) represents the angular momentum (spin), and the g -quantities are characterized by

$$\mu^S = \mu_P g^S S, \tag{5.80}$$

$$\mu^L = g^L \times L, \tag{5.81}$$

$$g_p^L = 1, \quad g_n^L = 0, \tag{5.82}$$

$$g_p^S = 5.585, \quad g_n^S = -3.816, \quad \mu_P = 1, \tag{5.83}$$

where \widehat{L} , \widehat{S} and \widehat{g} are the isotopic expressions, and N is the total number of isonucleons.

To a good approximation, the *density* b_{4k} of individual nucleons can be assumed to be the same for all nucleons. Santilli selects value (5.65) because it represents the density of nucleons as derived from other fits, by reaching in this way the expression

$$b_4 = n_4^{-1} = 1.652, \quad b_4^{-1} = n_4 = 0.605, \quad (5.84)$$

$$\widehat{g}_k^L = 0.654 \times b_{k3} \times g_k, \quad \widehat{g}_k^S = 0.654 \times b_{k3} \times g_k^S, \quad (5.85)$$

where we have assumed in first approximation that the isoproton and the isoneutrons experience the same mutation.

It is easy to see that the above model provides a numerically exact, quantitative resolution of total nuclear magnetic moments that had remained unachieved for about a century.

Consider first the case of the *deuteron*, that is a $p-n$ bound state in triplet S -state ($L = 0$), the state with $L = 1$ being unallowed by parity (that is preserved under isotopies). We then have the following *quantum mechanical (QM) and experimental values of the deuteron magnetic moment*

$$\mu_{\text{QM}}^D = g_p + g_n = 0.879, \quad (5.86)$$

$$\mu_{\text{exp}}^D = 0.857 \text{ (for } \mu_p = 1\text{)}. \quad (5.87)$$

Note that the quantum mechanical representation is in *excess* of the experimental value. Therefore, the exact representation requires a *reduction* of the above theoretical values. In turn, this implies *the prediction of a prolate spheroidal deformation of nucleons* (in which the rotation occurs along the symmetry axis), because an oblate deformation would imply an increase of the magnetic moment (classically due to the increase of the tangential speed of the charge distribution).

By comparison, we have the following *deuteron magnetic moment as exactly represented by Santilli via hadronic mechanics (HM)*

$$\mu_{\text{HM}}^D = b_3/b_4 \times (g_p + g_n) = \mu_{\text{exp}}^D = 0.857, \quad (5.88)$$

$$b_3 = n_3^{-1} = 1.490, \quad (5.89)$$

$$b_4 = n_4^{-1} = 1.652. \quad (5.90)$$

The remaining two semiaxes of the isonucleons (evidently assumed to be spheroid ellipsoids due to spin) can be identified via the condition used earlier that mutations of shape must conserve the density (or volume) of the nucleon. Therefore, Santilli introduces the condition

$$n_1^2 \times n_2^2 \times n_3^2 = 1, \quad (5.91)$$

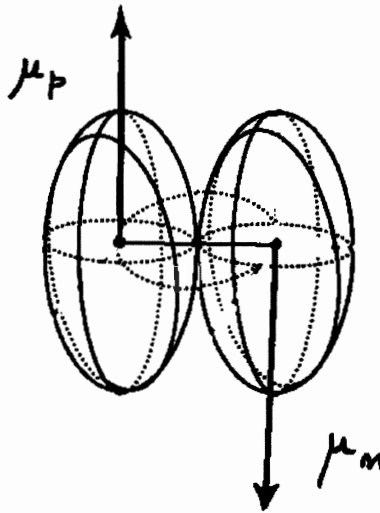

Figure 5.13. A schematic view of the structure of the deuteron according to Santilli. The fundamental assumption is the rather natural expectation expressed by the founders of nuclear physics that, when coupled into the deuteron, protons and neutrons experience a deformation of their shape when isolated in vacuum (assumed to be perfectly spherical from Dirac's equation). The deviation of the experimental value of the total magnetic moment of the deuteron from the quantum mechanical predictions (about 1% in excess) then yields a numerical characterization of the deformation of the nucleonic shape, that results to be prolate spheroid ellipsoids as depicted in the figure from values (5.92). Note that the configuration of the figure is centrally dependent on Santilli's isosymmetris because the latter characterize the deuteron as a closed-isolated system with conventional Hamiltonian interactions and additional non-Hamiltonian contact forces, thus assuring the presence of a contact between the proton and the neutron as a condition to preserve the nuclear force.

from which he obtains the value of all semiaxes of the two isonucleons in the deuteron

$$n_1^2 = n_2^2 = 1.490, \quad n_3^2 = 0.450. \quad (5.92)$$

As one can see, *hadronic mechanics achieves an exact and invariant representation of the deuteron magnetic moment, by confirming the prediction that the alteration is prolate.* The physical interpretation of the representation is so simple to be trivial (see Figure 5.13 below). The above model should be refined via different mutations of the isoproton and the isoneutron, evidently expected from their different values of charge and other features. This study is left to the interested reader.

The above results will be re-examined in Chapter 8 with a deeper structure model of the deuteron in which the neutron is reduced to its constituents. The extension of the above model to an exact representation of the magnetic moment of the tritium and all other nuclei is straightforward and it is left to the interested

reader, jointly with refinements due to D -couplings, pionic currents and other aspects here basically inessential to illustrate the exact representational capability of hadronic mechanics compared to the approximate capabilities of quantum mechanics.

5.3.C *Experimental verifications with the nuclear force*

Additional, perhaps more important verifications of hadronic mechanics are given by its representation of the *nuclear force*. As recalled in Chapter 1, quantum mechanics solely allows the use of a Hamiltonian for the representation of all nuclear structures. Consequently, the sole possible time invariant representation of the nuclear force is that via potentials. After about one century of failed attempts, it is today known that such a representation is unable to provide an exact representation of the nuclear force, since the use of some 43 different potentials with 43 different parameters has failed to reach an exact result.

Santilli has truncated this sterile process of adding potentials to the kinetic energy because nuclear forces are of action-at-a-distance, potential type only partially, since their primary origin is of contact nonpotential character. In fact, experimental data on nuclear volumes compared to those on the volumes of the charge distributions of protons and neutrons (nucleons) established that, when members of a nuclear structure, nucleons are in conditions of partial mutual penetration of the hyperdense media in their charge distributions, resulting in an incontrovertible contact nonpotential interactions,

The only known time invariant representation of the nonpotential part of the nuclear force is that via Santilli isounit realized within the context of hadronic mechanics. Regrettably, we are not in a position to review this study because of its industrial implications for new clean energies preventing disclosure at this time. For a partial release of the studies, one may consult HMMC, Volume IV.

5.4 **Experimental Verifications in Chemistry and Superconductivity**

5.4.A *Experimental verifications in chemistry*

Chemistry constitutes one of the most important fields of experimental verifications of hadronic mechanics because the very notion of electron valence coupling is beyond a serious representational capability by quantum mechanics due to the presence in molecular structures of the interactions caused by deep wave-overlapping, not to mention the fact that identical electrons are predicted by quantum mechanics to repel each other and additional insufficiencies indicated in Chapter 1. Chapter 4 has been devoted to the experimental verifications and applications of hadronic mechanics in chemistry as well as biology. We here merely mention for completeness the achievement by hadronic mechanics of the

first known, numerically exact representation of molecular binding energies obtained from unadulterated first axioms without *ad hoc* parameters or “screening” functions fitted from the data, as well as other verifications.

5.4.B *The unreassuring condition of 20th century superconductivity*

As it was the case for particle physics, nuclear physics and chemistry, the condition of 20th century superconductivity was equally unreassuring because based on the unlimited applicability of quantum mechanics much beyond the limits of its conception and experimental verification, without any serious scrutiny. There is no doubt that superconductivity has made major advances in recent decades. However, there is equally no doubt that superconductivity is currently at the stage of atomic physics before the discovery of the structure of atoms. In fact, superconductivity is based on electrons bonded in *Cooper pairs*, yet no quantitative model exists or is actually permitted by quantum mechanics for such pairs since, as it is the case for valence bonds, electrons are predicted by quantum mechanics to repel each other. More specifically, quantum mechanics does achieve an excellent representation of an *ensemble* of Cooper pairs, the quantum insufficiency here referred to is for the *structure* of *one* Cooper pair. Note that electrons in Cooper pairs are so deeply bonded/correlated to have been detected crossing potential barriers in said bonded form.

The central role of Cooper pairs in superconductivity is due to the fact that the total magnetic moment of a Cooper pair is dramatically smaller than that of individual electrons (due to the antiparallel alignment of the two electrons). Therefore, Cooper pairs experience much less resistance than individual electrons in their hopping from one atom to another in a conductor, thus permitting *superconductivity* (see Figure 5.14).

Due to the inability by quantum mechanics to permit an *attractive* force between two *identical* electrons, researchers were forced to introduce new interactions seemingly experienced by electrons that have no counterpart in other branch of physics. We are referring to the so-called *phonons* and related new electron-phonon interactions that are assumed as permitting said attractive bond. Inspection of all other branches of physics reveals that phonons exist in the sound theory, but not at the particle level, thus casting shadows in the actual existence of phonons beyond the level of a purely mathematical formulation. Alternatively, the lack of existence of electron-phonon interactions outside superconductivity casts doubts as to whether the conjecture of phonons will survive the test of time.

Above all, the stretching of the validity of quantum mechanics for systems for which it was not built for is best manifested by the exhaustion of predictive capacities by the quantum formulation of superconductivity. In fact, all theoretical predictions of increasing the superconducting temperature have been exhausted,

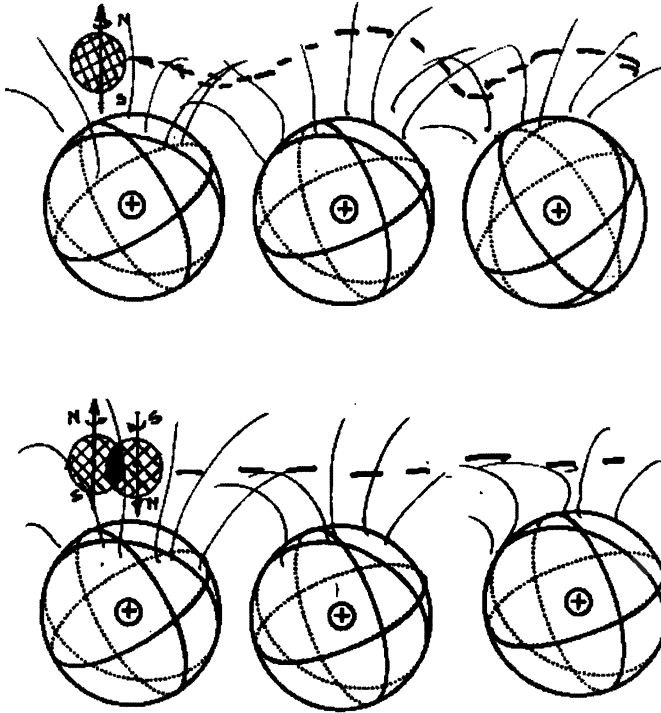

Figure 5.14. A schematic view of a conventional current of individual electrons (top view) and a superconducting current of Cooper pairs (lower view). The smaller electric resistance experienced by the latter as compared to that of the former current is due to the absence in the Cooper pair of an appreciable magnetic moment from its singlet structure, resulting in much smaller interactions with the atoms of the conductor. Note that we are here referring to a basically new current not yet industrially realized.

while all advances are attempted via phenomenological trials and errors without a sound guiding theory.

As it was the case for preceding fields, the approximate character of quantum mechanics in superconductivity is beyond doubt. Equally beyond doubt is the need for a deeper theory capable of providing a quantitative structure model of the Cooper pair, representing the various aspects in a way compatible with experiments and exhibiting novel predictive capacities for further advances.

5.4.C *Animalu's isosuperconductivity*

The research reported in this section originated with Santilli's proposal in 1978 to build hadronic mechanics, particularly with Section 5 of the paper [44] providing the first known representation of a bound state of one electron and one

positron at short distance with nonlocal, nonlinear and nonpotential interactions due to deep wave overlappings. In the papers [167,168] Animalu recognized that the strength of the attractive force of the new non-Hamiltonian interactions is such to overcome the Coulomb repulsion, and, therefore, be applicable also to the electron-electron correlation of the Cooper pair. By using Santilli's studies, Animalu then applied hadronic mechanics to produce the first known structure model of the Cooper pair and built a new theory today known as *Animalu isosuperconductivity*. Finally, Animalu and Santilli completed the structure model of the Cooper pair via hadronic mechanics in the paper [92].

It is assumed the reader is aware of the fact that, according to hadronic mechanics *the constituents of the Cooper pair are "isoelectrons" and not conventional electrons*. As a matter of fact, it will soon become evident that, without the isotopic interpretation of particles, a structure model of the Cooper pair is impossible, thus confirming the basic limitations of quantum mechanics.

It is evident that we can only outline here some of the main aspects of Animalu's isosuperconductivity and its clear experimental verification. The first step is to exit from the class of equivalence of quantum mechanics. This task can be achieved via nonunitary transforms of equations studied in Section 3.11O. Consider the Schrödinger equation for one electron with mass m and charge $-e$ in the field of an identical electron

$$H \times |e\rangle = \left(\frac{p \times p}{2m} + \frac{e^2}{r} \right) \times |e\rangle = E \times |e\rangle, \tag{5.93}$$

$$p \times |e\rangle = -i\partial_r |e\rangle. \tag{5.94}$$

The image of the above equations under a nonunitary transform is given by

$$U \times U^\dagger = \hat{I} = 1/T \neq I, \tag{5.95}$$

$$(U \times U^\dagger)^{-1} = T, \tag{5.96}$$

$$U \times (H \times |e\rangle) = (U \times H \times U^\dagger) \times (U \times U^\dagger)^{-1} \times (U \times |e\rangle) = \hat{H} \times T \times |\hat{e}\rangle = E \times |\hat{e}\rangle, \tag{5.97}$$

$$U \times (p \times |e\rangle) = (U \times p \times U^\dagger) \times (U \times U^\dagger)^{-1} \times (U \times |e\rangle) = \hat{p} \times T \times |\hat{e}\rangle = -iU(\partial_r |e\rangle) = -i\hat{\partial}_r |\hat{e}\rangle = -i\hat{I} \times D_r |\hat{e}\rangle, \tag{5.98}$$

where \hat{e} represents the wavefunction of the **isoelectron**, \hat{D}_r represent partial isoderivative, and

$$\hat{H} \times T \times |\hat{e}\rangle = \left[\left(\frac{\hat{p} \times T \times \hat{p}}{2\hat{m}} + \frac{e^2}{r} \right) \times \hat{I} \right] \times T \times |\hat{e}\rangle = E \times |\hat{e}\rangle. \tag{5.99}$$

However, the creation of Cooper pairs requires an "external trigger" (in the language of hadronic mechanics). Since identical electrons repel each other, and

since the new attractive non-Hamiltonian interactions only occur at short distances of the order of 1 fm, without an external action identical electrons would never form the Cooper pair.

It is evident that the “trigger” for the formation of the Cooper pair must be constituted by positive charges. Animalu’s studies of the issue have discovered that the needed trigger can be provided by *Cuprate ions* as well as other compounds. The latter are purely quantum mechanical (because they act for large distances as compared to the range of applicability of hadronic mechanics). Therefore, the interaction of Cuprate ions must be merely added to the short range hadronic state resulting in the expression

$$\hat{H} \times |\hat{e}\rangle = \left[\left(\frac{\hat{p} \times T \times \hat{p}}{2\hat{m}} + \frac{e^2}{r} \right) \times \hat{I} - \frac{z \times e^2}{r} \right] \times T \times |\hat{e}\rangle = E' \times |\hat{e}\rangle, \quad (5.100)$$

where the positive charge ze is the ionic valence and the conventional quantum nature is expressed by the lack of multiplication by \hat{I} . Note that one could equivalently write the quantum model and add the hadronic effects at short range by achieving the same results. At this point Animalu selected the following realization of the isounit and isotopic element:

$$\hat{I} = e^{-\langle \hat{e}_\uparrow | \hat{e}_\downarrow \rangle \times e_\downarrow / \hat{e}_\downarrow} = 1 - \langle \hat{e}_\uparrow | \hat{e}_\downarrow \rangle \times e_\downarrow / \hat{e}_\downarrow, \quad (5.101)$$

$$T = e^{+\langle \hat{e}_\uparrow | \hat{e}_\downarrow \rangle \times e_\downarrow / \hat{e}_\downarrow} = 1 + \langle \hat{e}_\uparrow | \hat{e}_\downarrow \rangle \times e_\downarrow / \hat{e}_\downarrow, \quad (5.102)$$

where \hat{e}_\uparrow and \hat{e}_\downarrow represents the wavefunction of the isoelectron with spin up and down, respectively, and e_\downarrow represents the wavefunction of the ordinary electron.

Note that isounit (5.101) provides a direct representation of the new interactions caused by deep waveoverlapping of the wavepackets of the isoelectrons that are *nonlocal* because represented by the volume integral, *nonlinear* because depending on the wavefunctions in a nonlinear way, and *nonpotential* because of clear contact/zero range type not representable with a Hamiltonian.

Most importantly, readers should keep in mind the short range character of the above isotopic lifting since isounit (5.101) recovers the trivial unit I for all distances sufficiently greater than 1 fm for which the volume integral is null. Under these conditions hadronic mechanics recovers quantum mechanics uniquely and identically. Therefore, *we are here presenting new correlations solely occurring at short distances where quantum mechanics is inapplicable, while recovering quantum mechanics identically for all longer distances*. This point is important because it will eliminate the need for the conjecture of phonons as physical quantities. In order to obtain an explicit structure equation for the Cooper pair, we use the following behavior

$$e_\downarrow = A \times e^{-r/R}, \quad (5.103)$$

$$\hat{e}_\downarrow = B \times (1 - e^{-r/R})/r, \quad (5.104)$$

where the first expression is known from atomic physics, the second expression was identified in [44], and R represents the charge radius of the Cooper pair. After substitution in Eq. (5.100) and turning the isokinetic energy into a renormalization \hat{m} of the electron mass m (another standard procedure of hadronic mechanics), we obtain the differential equation

$$\left[\frac{p^2}{2 \times \hat{m}} + \frac{(z-1)e^2}{r} - V \times \frac{e^{-r/R}}{1 - e^{-r/R}} \right] \times |\hat{e}\rangle = E \times |\hat{e}\rangle, \quad (5.105)$$

where one recognizes the familiar *Hulthen potential* first identified in Santilli's 1978 proposal that also provided a detailed analytic solution of the above equation whose main lines can be summarized as follows. In essence, *at short distances the Hulthen potential behaves like the Coulomb potential by therefore absorbing the repulsive contribution by the latter and resulting into a very strong attractive force between the two identical electrons in singlet couplings.* In fact, at short distance Eq. (5.105) yields the following *structure equation of the Cooper pair of isoelectrons*

$$\left[\frac{p^2}{2 \times \hat{m}} - K \times \frac{e^{-r/R}}{1 - e^{-r/R}} \right] \times |\hat{e}\rangle = E \times |\hat{e}\rangle, \quad (5.106)$$

where K is the new constant (in lieu of the original V) absorbing the coefficient of the repulsive Coulomb force.

The solutions of equation (5.106) yields the familiar *Hulthen energy spectrum*

$$E = - \left(\frac{\hat{m} \times K \times R^2}{\hbar^2 \times n} - n \right)^2 \times \frac{\hbar^2}{4 \times \hat{m} \times R^2}, \quad n = 1, 2, 3, \dots \quad (5.107)$$

5.4.D Experimental verification of Animalu's isosuperconductivity

Santilli [44] identified the solution for the structure of the π^0 via the introduction of the two parameters

$$k_1 = \hbar/2 \times \hat{m} \times R^2 = 0.34, \quad k_2 = \hat{m} \times K \times R^2/\hbar = 1 + 8.54 \times 10^{-2}. \quad (5.108)$$

Animalu identified the solution for the Cooper pair via the parametrization for the ground state

$$k_1 = F \times R/\hbar \times c_0, \quad k_2 = K \times R/F, \quad (5.109)$$

$$|E_{\text{Cooper Pair}}| = 2 \times k_1 \times [1 - (k_2 - 1)^2/4] \times \hbar \times c_0/R, \quad (5.110)$$

where F is the *Fermi energy of the isoelectron*. Eq. (5.110) can be written in good approximation

$$|E_{\text{Cooper Pair}}| = k_2 \times T_c/q_D, \quad (5.111)$$

where T_c is the *superconducting temperature* and q_D is the *Debye temperature*.

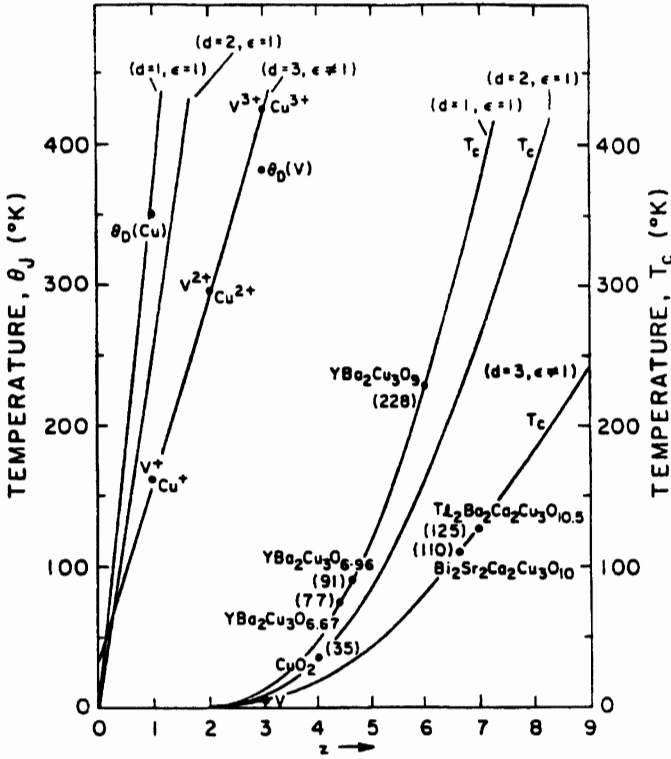

Figure 5.15. Animalu’s [loc. cit.] remarkable experimental verification of isosuperconductivity. The figure shows the plot between the theoretical prediction for the dependence of the superconducting temperature from the effective valence z of cuprate ions (continuous curve) and the experimental values on the “jellium temperature” for various compounds (solid dots).

Animalu then worked out several examples, such as

$$\text{Aluminum : } q_D = 428^\circ K, T_c = 1.18^\circ K, k_1 = 94, k_2 = 1.6 \times 10^{-3}, \quad (5.112)$$

$$\text{YBa}_2\text{Cu}_3\text{O}_{6x} : k_1 = 1.3 \times z^{-1/2} \times 10^{-4}, k_2 = 1.0 \times z^{1/2}, \quad (5.113)$$

where the effective valence z varies from a minimum of $z = 4.66$ for $\text{YBa}_2\text{Cu}_3\text{O}_{6.96}$, $T_c = 91^\circ K$, to a maximum of $z = 4.33$ for $\text{YBa}_2\text{Cu}_3\text{O}_{6.5}$, $T_c = 20^\circ K$. The general expression predicted by Animalu isosuperconductivity for $\text{YBa}_2\text{Cu}_3\text{O}_{6-x}$ is given by

$$T_c = 367.3 \times ze^{-13.6/z}, \quad (5.114)$$

and it is in remarkable agreement with experimental data (see the figures below).

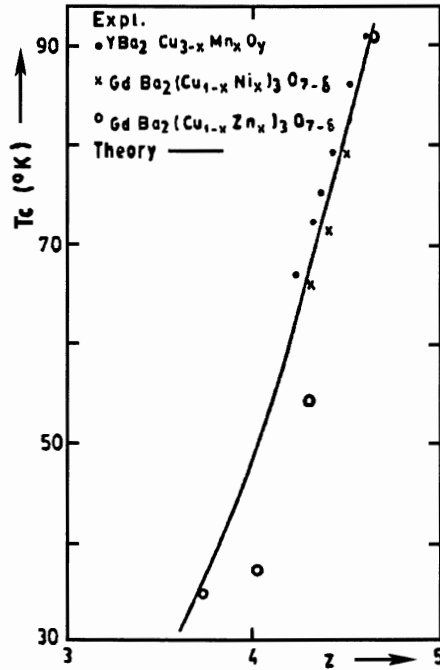

Figure 5.16. A reproduction of Fig. 5, p. 380 of Animalu [loc. cit.] showing the agreement between the prediction of isosuperconductivity for the doped 1:2:3 Cuprates and the experimental data.

The constant K can be written as $K = \hbar \times \omega$, where ω can be interpreted as the (average) phonon frequency. Expression (5.113) can then be rewritten

$$|E_{\text{Cooper Pair}}| = 2 \times k_1 \times k_3 \times c_0/R \times (e^{1/NV}), \tag{5.115}$$

where NV is the (dimensionless) electron-phonon coupling constant. The main results of Animalu’s model can therefore be reformulated in terms of the electron-phonon interactions, as expected. However, as also expected, the conjecture of the phonon is replaced in the model with the new non-Hamiltonian interactions for the simple reason that phonons have not been independently detected in particle or other branches of physics.

5.4.E Initial basic laws of hadronic mechanics

By combining the results and experimental verifications of Santilli’s isochemistry studied in the preceding chapter and Animalu’s isosuperconductivity studied in this section, we are now in a position to identify the following three initial basic laws of bound states at short distances represented via hadronic mechanics

Table 1. $\text{YBa}_2\text{Cu}_{3-x}\text{Mn}_x\text{O}_y$
(After N.L. Saini *et al.*, *Int. J. Mod. Phys. B*6, 3515 (1992))

x	y	z	T_c (theory)	T_c (expt.)
0.00	6.92	4.613	88.9	91
0.03	6.88	4.541	83.5	86.6
0.09	6.87	4.447	76.7	79.0
0.15	6.91	4.387	72.6	75.0
0.21	6.92	4.312	67.6	72.0
0.30	6.95	4.212	61.3	67.0

Note: T_c (theory) = $367.3z \exp(-13.6/z)$, where the effect of replacing Cu_3 by $\text{Cu}_{3-x}\text{Mn}_x$ is obtained by replacing 3 by $(3-x)+2x=3+x$, which lowers the effective valence (z) on Cu^{2+} ions to $z=2y/(3+x)$.

Table 2. $\text{GdBa}_2(\text{Cu}_{1-x}\text{Ni}_x)_3\text{O}_{7-\delta}$
(After, Chin Lin *et al.*, *Phys. Rev. B*42, 2554 (1990))

x	$y = 7-\delta$	z	T_c (theory)	T_c (expt.)
0.000	6.96	4.640	91.0	91
0.025	6.96	4.527	82.4	79
0.050	6.96	4.419	74.8	71
0.075	6.96	4.316	67.9	65

Note: T_c (theory) = $367.3z \exp(-13.6/z)$, $z = 2y/3(1+x)$ as discussed in Table 1.

Table 3. $\text{GdBa}_2(\text{Cu}_{1-x}\text{Zn}_x)_3\text{O}_{7-\delta}$
(After, Chin Lin *et al.*, *Phys. Rev. B*42, 2554 (1990))

x	$y = 7-\delta$	z	T_c (theory)	T_c (expt.)
0.000	6.96	4.640	91.0	91
0.025	6.96	4.309	67.4	54
0.050	6.96	4.009	49.0	37
0.075	6.96	3.737	36.1	35

Figure 5.17. A reproduction of the tables of p. 379, Ref. [168] illustrating the agreement between the predictions of isosuperconductivity with experimental data from other profiles.

(see Chapter 7 for additional laws) that were fully identified by Santilli in his original proposal of 1978 to build hadronic mechanics:

Basic law I of hadronic mechanics: *Nonlinear, nonlocal and nonhamiltonian interactions due to wave-overlappings of spinning particles at short distances are always attractive when in singlet couplings and such to absorb repulsive or attractive Coulomb interactions, resulting in total strongly attractive interactions irrespective of whether the Coulomb interactions are attractive or repulsive.*

As the reader will remember, the above law is at the foundation of the Santilli-Shillady strong valence that permitted the first exact representation of molecular data from unadulterated first principles. The same law is here verified in the structure of the Cooper pair in superconductivity. In the next chapter, we shall see that the same law is crucial for the synthesis of neutrons as occurring in stars from protons and electrons. Finally, the same hadronic law has a truly crucial

role for the conception, and industrial development of a basically new form of controlled nuclear fusions at intermediate energies.

Basic law II of hadronic mechanics: *Nonlinear, nonlocal and nonhamiltonian interactions due to wave-overlappings of spinning particles at short distances are always strongly repulsive when in triplet couplings irrespective of whether the Coulomb interactions are attractive or repulsive.*

The best way to see Laws I and II is that originally used by Santilli for their derivation, and of is known as the "gear model." In fact, ordinary gears can only be coupled in singlet, while the attempt of coupling them in triplet causes strong repulsive forces, or the breaking of the teeth.

In essence, Santilli's 1978 argument is that *particles are not points, but extended, and the interior of their wavepackets or charge distribution is not empty, but filled up with a dense physical medium.* Therefore, the axioms of quantum mechanics (when used without adulteration via arbitrary functions fitted from the data) predict no difference between singlet and triplet couplings. By contrast, hadronic mechanics represents the actual extended shape of particles and their density, resulting in the unavoidable Basic Laws I and II.

Basic law III of hadronic mechanics: *Bound states of particles due to wave-overlappings at short distances in singlet coupling suppress the atomic spectrum of energy down to only one possible level, a property called "hadronic suppression of the atomic energy spectra."*

The mechanism of the above suppression is to the finite character of the number of energy levels admitted by the Hulthen potential combined with the fact that all known fits of the solutions to experimental data reduce such a finite spectrum to only one energy value, that of the considered state.

The above property illustrates the dramatic structural differences between quantum and hadronic mechanics and it is forcefully verified in various fields of physics. To begin, the idea that valence electron bonds have a spectrum of energy levels of atomic type has no physical value or credibility since the valence bond is one and only one. We have a similar situation for the Cooper pair for which any introduction of quantum energy levels in its structure would cause dramatic disagreements with experimental data. Similarly, when the neutron is synthesized in the interior of stars from a proton and an electron, its energy level is unique in the sense that possible excited states do not characterize the neutron any more. The same holds for all hadronic bound states.

It should be stressed that the elimination of the energy spectrum is here referred to solely within the context of *hadronic and not quantum mechanics.* In fact, a proton and an electron can indeed have an infinite number of excited levels as established by the hydrogen atom. The main point is that all these excited states cause the increase of the mutual distances with consequential elimination of the new hadronic forces and the transition to the full validity of quantum

mechanics. In fact, as we shall see in the next chapter, all excited states of the neutron synthesized from a proton and an electron are those of the ordinary hydrogen atom from which the neutron originated. The same occurrence holds for electron bonds in the valence, Cooper and other pairs.

5.5 Experimental Verification with the Behavior of Light

5.5.A *The inevitability of the ether as a universal medium*

As it is well known in the history of physics, Alhazen initiated in 1021 the conception of light as made up of particles, a conception originated from the capability of light to have momentum, and that was subsequently supported by numerous scientists, most notably by Newton.

The advent in 1873 of Maxwell's equations introduced the alternative conception of light as an *electromagnetic wave* propagated by a universal substratum, the *ether* by resolving known insufficiencies of the conception of light as being made up of particles, such a refraction.

In the early part of the 20th century, the admission of a universal substratum caused problematic aspects for the then emerging special relativity, since its basic axiom on the absence of a privileged reference frame was clearly incompatible with the privileged reference frame of the ether. For the specific intent of removing the need of the ether, Einstein introduced in 1905 his celebrated hypothesis that light was made up of *photons* with energy $E = hf$ (where h is Planck's constant and f the frequency), which hypothesis was supported by the then emerging discovery on the black body radiation. Besides the need to eliminate an absolute reference frame, the photon hypothesis received support from the absence of the so-called *etherial wind*, namely, the resistance that Earth and other bodies should experience when moving in space conceived as a medium.

Due to the vast experimental confirmations of the photon hypothesis in atomic spectroscopy, the rest of the 20th century was dominated by the reduction of light to photons with the consequential elimination of the ether as a universal substratum, despite Einstein's own doubts (expressed in some of his letters) on *the impossibility of reducing all electromagnetic waves to photons*, as it is evidently the case for electromagnetic waves with one meter wavelength, not to mention Einstein's doubts on the final character of quantum mechanics.

During his early studies in the 1950s, Santilli resolved the problem of the "etherial wind" by reducing all matter to oscillations of the ether (Section 3.2), identified various impossibilities of reducing all electromagnetic waves to photons, recalled the ultimate structure of photons themselves being *wavepackets*, and restored the Maxwellian conception of electromagnetic waves propagating in the ether as a universal substratum. From the transversal character of the waves,

Santilli concludes in his early works of 1952 that the ether is a universal medium of very big rigidity and energy density. As Santilli puts in his early works of 1950s: *“You can hear my voice because there is a medium, the atmosphere, propagating sound waves, in which absence sound does not exist. Similarly, you can see my face because of the existence of a universal medium, the ether, creating and propagating light. In the absence of such a medium, light cannot exist, let alone cannot propagate. The longitudinal character of sound waves (oscillation in the direction of propagation) confirms that the atmosphere is a compressible medium without rigidity. Consequently, the sole possible interpretation of the transversal character of light (oscillations perpendicular to the direction of propagation) is that the ether is a medium with a primary characteristic we call “rigidity.” The very big value of the speed of light can solely be represented with the assumption of the ether as a medium with extremely big rigidity and, consequently, very big energy density.”*

This chapter in general, as well as this section in particular, are devoted to the outline of the vast experimental evidence accumulated since the early 1950s confirming Santilli’s original conceptions of the early 1950 according to which:

1) Electromagnetic waves are created and propagated by the ether as a universal medium with very big rigidity and energy density;

2) When electromagnetic waves have a sufficiently small wavelength to allow their meaningful reduction to photons and related interactions with atoms, photons themselves are not “particles,” but wavepackets with well defined frequency and wavelength, thus also requiring a universal medium for their very existence and propagation;

3) Electromagnetic waves propagate in vacuum at the speed c , thus verifying the Lorentz-Poincaré symmetry of empty spacetime, and propagate within physical media at the locally varying speed $C = c/n$, where n is the local index of refraction depending on the frequency of the waves f , density of the medium d , and other local variables, $n = n(f, d, \dots)$.

It is hoped that the experimental evidence presented in this chapter establishes that, contrary to political views of having achieved final knowledge on light, following one millennium of studies our knowledge of light is far from being established. It is also hoped that said experimental evidence establishes the need for the interpretation of the ether as a universal substratum characterizing all visible entities in the universe. As Santilli’s puts it (see next chapters for details): *“The study of the ether as a universal substratum is the ultimate scientific frontier of the third millennium, with potential advances such as longitudinal communications millions of time faster than the speed of transversal waves, spaceships moving at arbitrary speeds without fuel thanks according to geometric locomotions, and other advances beyond our most vivid science fictions of this time.”*

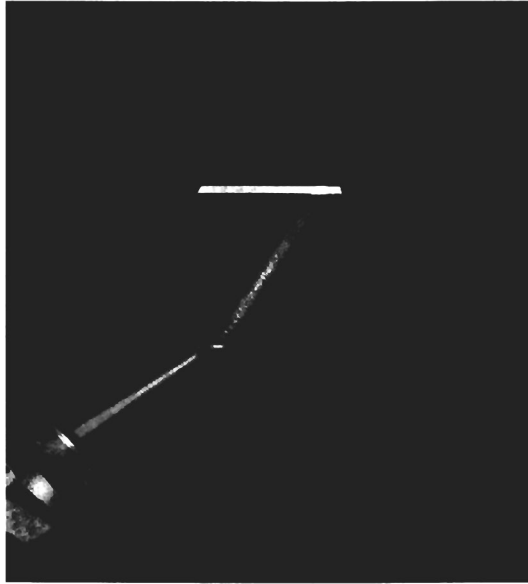

Figure 5.18. Light propagating within water constitutes visual experimental confirmation of Santilli's isorelativity due to the impossibility of quantitative representations via the reduction of light to photons scattered among water molecules, and the necessity of the local speed $C = c/n$ as outlined in the text.

In this section we review Santilli's studies as summarized in his 1991 monographs [9, 10] (hereon referred to as "Santilli 1991"), Santilli's contributed paper [124] at the 2007 ICDS conference in Bolu, Turkey (hereon referred to as "Santilli 2007"), and in the recent paper [130] (hereon referred to as "Santilli 2009").

5.5.B *Experimental verification with light propagating in water*

Since Einstein's proposal of 1905, light propagating within a transparent physical medium, such as water (see Fig. 5.18), has been reduced to photons scattered by the atoms of the medium, or absorbed by the same and then re-emitted. The evident intent or implication is that of rendering special relativity applicable within physical media, since light is reduced to photons propagating in vacuum, with the consequential elimination of the ether as a universal medium.

Despite one century of studies along the latter lines, the reduction of light to photons propagating within physical media remains afflicted by numerous insufficiencies, such as (see Santilli 1991, 2007 and 2009):

- 1) Fig. 5.18 provides visual evidence of the impossibility of reducing the propagation of light in water to photons scattered among or absorbed by the water molecules, since such a reduction would imply that the great majority of photons must propagate through a very large number of nuclei, as a condition to explain

the preservation of the beam. To the authors' best knowledge, only the interpretation of light as a transversal electromagnetic wave propagating within the ether represents the visual evidence of Fig. 5.18 because, in this case, the propagation occurs in the universal substratum underlying nuclei.

2) The reduction of light to photons prevents a numerical representation of the (rather large) angle of refraction of light at the water surface. In fact, photons are expected to be scattered or be re-emitted in all directions after hitting the water surface, rather than follow the refractive direction of the beam illustrated in Fig. 5.18. Again, the refraction can be solely represented by the wave interpretation of light with the *locally varying speed* $C = c/n(f, d, \dots)$, where n is the index of refraction (bigger than 1) so familiar prior to Einstein's times.

3) The reduction of light to photons scattered by the water molecules cannot represent the rather large decrease (by about 1/3) of the speed of light in vacuum c when propagating in water, because its numerical representation via photon scatterings would require a virtually complete dispersal of the beam against the visual evidence of Fig. 5.18. A numerical representation via absorption and re-emission of photons is also impossible due to the virtually instantaneous re-emission of absorbed photons. Again, the sole known quantitative representation of the speed of light in water is the historical form $C = c/n$.

4) The reduction of light to photons is additionally unable to represent experimental evidence on the behavior of electromagnetic waves with large wavelength (such as radio waves with one meter wavelength) when traveling within physical media, since such waves experience the same phenomenology of visible light, yet the reduction of large wavelengths to photons is no longer effective, e.g., due to a dramatic decrease in quantitative predictions via scattering and absorption. Again, the return to the Maxwellian interpretation of light as an electromagnetic wave propagating through the ether is the sole known capable of providing a *numerical representation* of the local speed of light for all wavelengths. The indication of published evidence to the contrary would be appreciated, with particular reference to the *numerical* (rather than conceptual) representation of physical evidence via the reduction to photons of electromagnetic waves with *large* wavelength.

5) The reduction of light to photons traveling in vacuum is finally incompatible with the existence within hyperdense physical media of causal speeds bigger than that of light in vacuum, as expected in the interior of gravitational collapse. At any rate, electromagnetic waves propagating at speeds $C = c/n$ bigger than c , n smaller than 1, have already been identified in laboratory for propagation within special guides reviewed in Section 5.2C, and data elaborations in hadron physics without the aprioristic assumptions of special relativity, systematically show maximal causal speeds within the hyperdense medium inside hadrons as being bigger than that in empty space. In the final analysis, the idea that the

maximal causal speed inside a black hole is the same as that in vacuum, has no credibility, let alone no hope for direct experimental verification.

Needless to say, the scattering, as well as absorption followed by re-emission, of photons by the atoms of the medium are beyond doubt, but they can only provide a quantitative representation of the *partial* dispersal of the light beam within a transparent physical medium with consequential moderate decrease of its intensity as per visible evidence of Fig. 5.18. Also, Maxwell's wave interpretation of light is not in conflict with its reduction to photons because, as recalled in Section 2.1, photons are not "solid particles," but wavepackets. As such, the reduction of light to photons cannot credibly bypass the fundamental need for the ether allowing the photon wavepackets to exist and propagate.

In summary, due to the impossibility of a *numerical* representation of *all* aspects at hand, the above evidence establishes the merely conceptual nature of the reduction to photons of light propagating in water as well as the intent of adapting special relativity to conditions it was not conceived or verified for. The sole quantitative representation known to the authors is that via the Maxwell's conception of light as a transversal electromagnetic wave crated and propagated by a universal substratum, with the consequential local character of the speed of light $C = c/n(f, d, \dots)$. The validity of Santilli's isorelativity is then consequential due to its universal symmetry of local speeds of light.

5.5.C Santilli isoredshift

As it is well known, a central prediction of special relativity is the *Doppler redshift*

$$f' = \gamma^{-1} f_0 \approx (1 - \beta + \beta^2 + \dots) f_0, \quad (5.116)$$

$$\beta = v/c, \quad \gamma = (1 - \beta^2)^{-1/2}, \quad (5.117)$$

establishing that, when the source of light moves *away* from the observer, the frequency of light f is shifted toward the *red*. This law has been experimentally verified numerous times and confirmed as being *exactly valid for the propagation of light in vacuum*, a feature tacitly assumed hereon.

Despite these successes, the Doppler redshift has no experimental verification at all for the propagation of light within transparent physical media. In this case, light is generally reduced to photons scattering among or absorbed by the molecules of the medium. Law (5.116) is then recovered from the fact that photons propagate in vacuum.

Santilli's studies have provided a dramatic revision of the latter beliefs. First of all, Santilli (1991) has established the need for the return to the interpretation of light as electromagnetic waves propagating within a universal substratum. Secondly, Santilli has re-established the speed of light as the local variable $C = c/n$ used for centuries prior to Einstein. Thirdly, Santilli has proved that, when

the speed of light within a physical medium is no longer c , the universal Lorentz-Poincaré-Santilli isosymmetry for all possible local speeds $C = c/n$ characterizes the *Doppler-Santilli isoredshift* reviewed in Section 3.10G, Eq. (3.98)

$$\hat{f} = \hat{\gamma}^{-1} f_0 \approx (1 - \hat{\beta} + \hat{\beta}^2 + \dots) f_0 = [1 - \beta(n_4/n_3) + \beta^2(n_4/n_3)^2/2 + \dots] f_0, \quad (5.118)$$

$$\hat{\beta} = vn_4/cn_3, \quad \hat{\gamma} = (1 - \hat{\beta}^2)^{-1/2}, \quad (5.119)$$

where n_4 is the local index of refraction, and n_3 is the space characteristic quantity of the medium in the direction of propagation of light.

The above isolaw establishes that, since n_4 is bigger than n_3 (for all media of moderate density such as air or water), when the light source moves *away* from the observer and *light propagates within a physical medium*, there is a redshift *bigger* than that predicted by special relativity. The above law was then confirmed in astrophysics by Mignani in 1992 and in other fields as reviewed in the next section.

At the ICDS conference in Bolu, Turkey, of 2007, Santilli pointed out that isoredshift (5.118) admits no divergent value for $v = c$ and, similarly, it does not admit a null shift for $v = 0$ because the space characteristic quantity n_3 generally depends on the speed, energy and other quantities. In this way, Santilli formulated the isotopic redshift for null speeds

$$\hat{f} \approx (1 - s/C) f_0, \quad (5.120)$$

$$s = \lim_{v=0} v/n_3, \quad C = c/n_4, \quad (5.121)$$

today known as *Santilli isoredshift* and referred to a *shift toward the red of the frequency of light propagating within a transparent physical medium without any relative motion among the source, the medium and the observer*.

Santilli's argument is that, when propagating within a physical medium, light loses energy $E = hf$ to the medium due to interactions, with consequential decrease of the frequency f . Alternatively, the geometric interpretation is that a physical medium, whether characterized by matter or light, causes the mutation of the Minkowski spacetime of the vacuum with consequential decrease of its speed and resulting decrease of the frequency.

In his 2007 paper [loc. cit.], Santilli discusses in details the structural differences between his isoredshift and the numerous proposals intended to eliminate the expansion of the universe known as *tired light*. In fact, all the latter hypotheses assume the reduction of light to photons propagating in vacuum at the speed c , while Santilli isoredshift is based on a structural change of spacetime with alteration of the speed of light caused by intergalactic physical medium (see next section). Santilli 2007 paper ends with the proposal of three easily feasible experiments for the verification of the denial of his isoredshift.



Figure 5.19. A view of the Isoredshift Testing Station built by Santilli in June 2009 at the laboratory of the Institute for Basic Research in Florida. Additional pictures are available from the website <http://www.santilli-foundation.org/Isoredshift-Testing-Station.html> (Isoredshift Testing Station, R. Anderson, The R. M. Santilli Foundation).

5.5.D Experimental confirmation of Santilli's isoredshift

In his recent paper of 2009, Santilli reported preliminary confirmations of the isoredshift via the following realization of Experiment 10.2, page 237, Santilli 2007. For this scope, Santilli built a schedule 80, high pressure, carbon steel pipe 60' = 28.3 m long, 5" = 12.7 cm in outside diameter, and transparent ends with 2" = 5.6 cm thick lexan. The pipe was filled up with filtered air at 2,000 psi = 138 bar pressure. A monochromatic blue light with wavelength 473 nm from a 100 mW diode laser was passed through the pipe and its wavelength measured *in air* following said passage, with an accuracy to a fraction of a nm. The compressed air inside the pipe was discharged by restoring atmospheric pressure, but keeping the two lexan terminals. The same monochromatic blue light was then passed through the pipe at atmospheric pressure and its wavelength measured *also in air* after passing through the pipe with the same experimental set up used at pressure and without any alteration.

A comparison of the data shows a clear increase over background/or statistical fluctuations of the wavelength of light λ_2 passing through the pipe at 2,000 psi = 138 bar compared to the wavelength λ_1 at atmospheric pressure. In particular, as shown in Figs. 6 and 5.20, the measurements showed a redshift characterized by the deviation of the blue laser light well over background of about 0.5 nm,

$$\lambda_2 \approx \lambda_1 + 0.5 \text{ nm}, \quad (5.122)$$

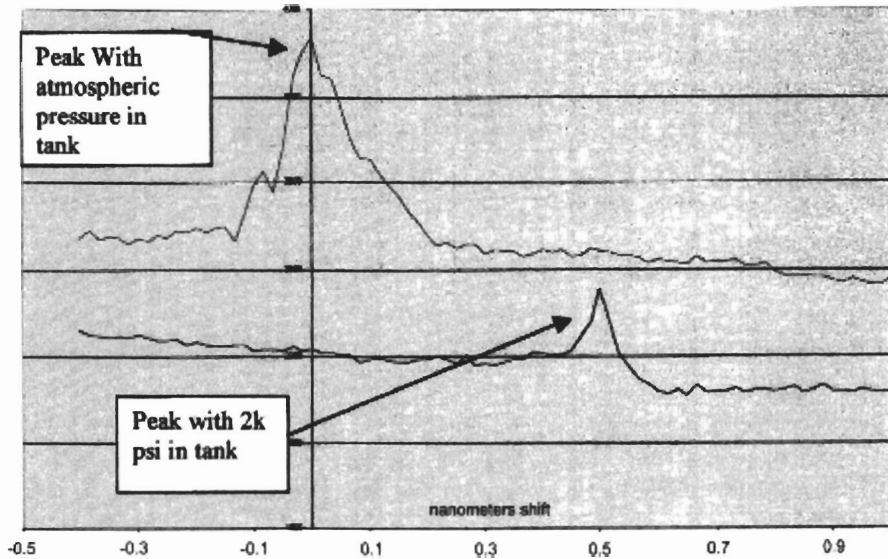

Figure 5.20. A view of the first detection of Santilli's isoredshift obtained in June 27, 2009, at the Isoredshift Testing Station of the preceding figure showing a clear increase of the wavelength with consequential clear decrease of the frequency of the used blue laser light. Additional pictures and data are available from the website <http://www.santilli-foundation.org/Sunset-Sunrise.html> (Inconsistencies of special relativity within physical media, R. Anderson, The R.M. Santilli Foundation).

when propagating through the indicated pipe plus the lexan terminals, compared to the same travel of the same light in air plus the travel through the two lexan terminals. Since the deviation occurs without any relative movement of the laser source, the medium or the detector, the above measurements confirm Santilli isoredshift. By assuming that the speed of light in air is the same as that in vacuum, the corresponding frequencies f_2 and f_1 are related to the wavelength by the known law

$$c = \lambda_2 f_2 = \lambda_1 f_1. \quad (5.123)$$

Therefore, the *increase* of the wavelength implies the *decrease* of the frequency, thus confirming Santilli isoredshift. Needless to say, the above measurements should be considered preliminary and in need of various reruns and improvements currently under way (October 2009). Nevertheless, isoredshift (5.121) has been released in view of: the consistency of the results; its compatibility with other propagations of light within physical media; as well as a number of unverified indications of similar isoredshifts all recommended for test, such as radio communications received on Earth from spaceships when passing in the back of planetary atmospheres, light propagating through long optical fibers, and other cases. All this information eliminates vacuous, not so unfrequent *theoretical* dis-

proofs of *measurements*, by confirming that *experimental measurements can be credibly dismissed solely with counter-measurements*.

5.5.E *Experimental verification with the colors our atmosphere*

The insufficiencies of the reduction of light to photons identified in the preceding section persist for all propagations within transparent physical media, not only on Earth, but also in astrophysics and cosmology (see next section).

As an additional example for conditions on Earth, consider the propagation of light in our atmosphere. Visual evidence establishes that, when the Sun is at the Zenith, our atmosphere is predominantly *blue* not only toward the Zenith, but also toward the horizon, while the atmosphere at Sunset and Sunrise is predominantly *red* (Fig. 5.21).

The interpretation of the above evidence assumed during the past century has been that the blue color of the sky is due to the scattering of (a small portion of the Sun) blue light, since red light is absorbed by the atmosphere. For Sunset and Sunrise the conventional interpretation is that we have the opposite occurrence, namely, we have the absorption of all light frequencies except for the frequencies of red light.

In Santilli's view, the interpretation of the blue color of the sky is correct and confirmed by experimental evidence of light propagating within other transparent physical media. For instance, the color of sea water becomes progressively blue with the increase of the depth, to the point that at about 20 m depth only the blue light remains visible, while all other colors are absorbed by the medium. In any case, the conventional quantum scattering theory confirms that the penetration of photons within a transparent medium is proportional to the frequency, the harder the photons, the deeper being the penetration. Alternatively, quantum scattering theory establishes beyond doubt that red light is absorbed by media much more than blue light.

By contrast, the current interpretation of the predominant red color at Sunset and Sunrise is in disagreement with various physical laws, being a mere consequence of the adaptation of physical reality to special relativity without prior independent experimental verifications.

Let us recall that the Earth perimeter (at the Equator) is of about 40,000 km. Hence, at Sunset we have the tangential speed *away from* the Sun

$$v = |v| = 40,000/24 \times 60 \times 60 = 0.4629 \text{ km/s.} \quad (5.124)$$

By recalling the conventional *Doppler shift law* for the frequency terminated at the first term in the expansion in terms of v/c ,

$$f = (1 - v/c)f_0, \quad (5.125)$$



Figure 5.21. Views taken by the author in Palm Harbor, Florida, of our horizon when the Sun is at the Zenith (left), at Sunset (top right) and Sunrise (bottom right), illustrating the predominant blue color when the Sun is at the Zenith and the predominant red color at both Sunset and Sunrise. Comprehensive color pictures are available in the website <http://www.santilli-foundation.org/Sunset-Sunrise.html> (Inconsistencies of special relativity within physical media, R. Anderson, The R.M. Santilli Foundation).

tangential speed (5.124) causes a conventional *Doppler redshift* with value

$$\Delta f = f - f_0 = -(v/c)f_0 = 1.554 \times 10^{-6} f_0 \quad (5.126)$$

that, being very small, is basically unable to represent the transition of the color of the sky at the horizon from blue during the day to red at Sunset (Fig. 5.21).

For the case of Sunrise, we move *toward* the Sun at speed (5.124), in which case we have the conventional *Doppler blueshift*

$$f = [1 + (v/c)]f_0, \quad (5.127)$$

$$\Delta f = f - f_0 = +(v/c)f_0 = 1.554 \times 10^{-6} f_0 \quad (5.128)$$

that, besides being also very small, its sign is in *violation* of visual evidence at the horizon of *red* rather than blue.

In summary, the strict application of special relativity to light requires that *Sunset should be red and Sunrise should be blue*.

By contrast, visual evidence establishes that this is not the case, because both Sunset and Sunrise are predominantly red, thus establishing the presence of physical conditions beyond those of the exact validity of special relativity in favor of Santilli's covering isorelativity as shown in the next section.

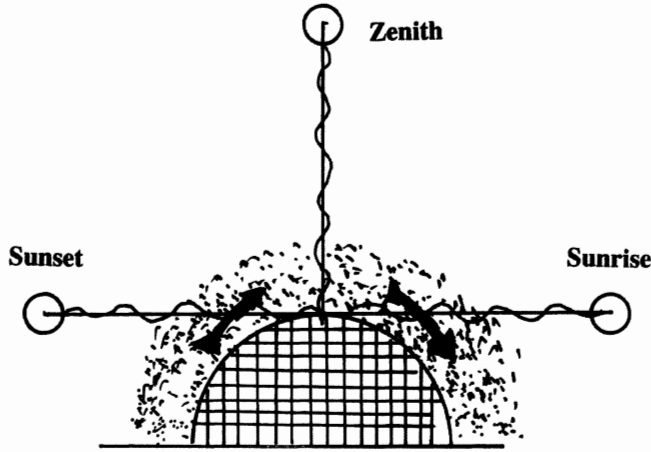

Figure 5.22. A schematic views by Santilli to illustrate the conventional Doppler redshift at Sunset and the conventional blueshift at Sunrise, as discussed in the text.

Assuming that with the introduction of unknown *ad hoc* parameters or functions, the above physical evidence for the behavior of light at Sunset and Sunrise is manipulated to verify special relativity, we still remain with the basic inability by special relativity to represent quantitatively the transition of the color of the horizon from blue to red at both Sunset and Sunrise, as shown in Fig. 5.21. Therefore, we reach the same conclusion as that of Section 5.5B, namely, that special relativity is *inapplicable* within physical media at large, whether gas or liquid (rather large departures for solids or hyperdense media are discussed below).

In his 2009 paper, Santilli has shown that isoredshift (5.121) provides a *numerical* representation of the color of our atmosphere at the Sunset and Sunrise, the blue color for the Sun at the Zenith being due to known absorption of the other colors. This numerical interpretation evidently provides significant support to the existence of Santilli isoredshift.

The color of our atmosphere is a very complex event because resulting from a number of different processes, such as:

- a) The scattering of photons among the atoms of our atmosphere that is proportional to the frequency, as established by the relativistic quantum scattering theory;
- b) The absorption of light by our atmosphere that is inversely proportional to the frequency, as established by the propagation of light within various transparent media, such as sea water;
- c) The Doppler redshift occurring at Sunset, Eq. (5.125);
- d) The Doppler blueshift occurring at Sunrise, Eq. (5.127); and

e) Santilli isoredshift that is proportional to the density of the transparent medium (as well dependent on other characteristics not essential for the problem at hand).

As shown in Section 3, the sole use of processes a) to d) does not allow a quantitative representation of all colors of our atmosphere. By contrast, the addition of isoredshift e) does indeed allow the first quantitative representation known to this author. Again, processes a) and b) do represent quantitatively the blue color of our atmosphere when the Sun is at the Zenith, including the color of the horizon, under the absorption of all colors with bigger wavelengths, in accordance with quantum scattering theory.

When passing to Sunset and Sunrise, we should equally assume that solely the blue light penetrates deep into the atmosphere and other colors are absorbed. In any case, if the red color is absorbed by our atmosphere when the Sun is at the Zenith, the same absorption becomes mandatory for a serious study when dealing with the much longer propagation of light at the horizon.

In this way, the problem of the color at Sunset and Sunrise is reduced to a quantitative study of the transition of blue to red light in both cases. The opposing contributions of Doppler's redshift at Sunset and blueshift at Sunrise are given by the measurable difference in red color between Sunset and Sunrise that is not addressed in this paper, but hoped it is measured by experimentalists in the field.

The blue light of the sky we are referring to has the wavelength of 470 nm, while the red light we see at Sunset and Sunrise has the wavelength of about 670 nm. Therefore, at Sunset and Sunrise we have the isoredshift

$$\Delta\lambda = \lambda_{\text{red}} - \lambda_{\text{blue}} = 200 \text{ nm} = 200 \times 10^{-9} \text{ m}. \quad (5.129)$$

Measurement (5.122) shows a deviation of 0.5 nm for blue light traveling for $60' = 28.3 \text{ m}$ in air at $2000 \text{ psi} = 138 \text{ bar}$. Assuming a linear proportionality of the isoredshift on length, a travel for 28.3 m at 138 bar is equivalent to the travel at 1 bar of

$$138 \times 28.3 \text{ m} = 3,905 \text{ km}. \quad (5.130)$$

Consequently, the needed isoredshift of 200 nm can be accounted for by the proportion

$$0.5 \text{ nm}/3.905 \text{ km} = 200 \text{ nm}/y \text{ km}, \quad (5.131)$$

$$y = 200 \times 3.905 \times 2 = 1,562 \text{ km}, \quad (5.132)$$

namely, measurement (5.122) predicts that blue light is shifted into red light when propagating for 1,562 km in atmosphere assumed at 1 bar.

However, Earth is curved and Sun light at Sunset and Sunrise passes from empty space to 1 bar approximately in 6,000 km according to a law that, in first

approximation, can be assumed as being inversely proportional to the square elevation from sea level. Consequently, 1,562 km are indeed a good approximation of the 6,000 km travel of light from empty space to 1 bar.

This confirms that Santilli isoredshift does indeed provide a quantitative representation of the predominance of red at Sunset and Sunrise. It should be noted that the full treatment of the colors at Sunset and Sunrise requires the Doppler-Santilli isoshift. This approach has not been considered in this paper due to the small value of the Doppler redshift (5.126) at Sunset and blue shift (5.128) at Sunrise, but it is hoped will be treated in a future paper.

5.6 Experimental Verifications in Astrophysics

5.6.A *The unreassuring condition of 20th century astrophysics*

One of the biggest controversies in the history of science has been the interpretation of the *cosmological redshift* via the “big bang” theory. This unreassuring condition has been aggravated more recently by additional controversies on far reaching conjectures, such as those of “dark matter” and “dark energy.”

Having been a former insider in high ranking academia, Santilli has repeatedly stated in his writings that all these conjectures have been proposed for the specific purpose of extending the applicability of Einsteinian theories well beyond the conditions of their conception and experimental verification, and that, to maintain their validity, said conjectures are collegially preferred over the more plausible possibility of deviations from special relativity under conditions beyond those of its original conception and experimental verification.

In fact, the “big bang” conjecture was specifically conceived and developed to adapt the expansion of the universe to a basic axiom of special relativity, Doppler’s redshift, despite the following inconsistencies pointed out by Santilli various times and expected to be known by experts to qualify as such:

A) Since the primordial explosion is assumed as being occurred about 15 billion years ago and occurred at one point in space, said explosion should have created a very large area in the universe without any galaxy at all, an occurrence disproved by astrophysical evidence on the distribution of galaxies throughout the universe;

B) Since the speed of galaxies is assumed to be proportional to the distance from Earth and be the same in all directions from Earth, the “big bang” conjecture causes a return to the middle age conception of Earth at the center of the universe, with the “big bang” occurred in its galactic environment, while alternative popular views (such as the “rubber band” model and the like) are excluded by the occurrence of the primordial explosion at one point in space with consequential necessary anisotropy;

C) The “big bang” conjecture is ultimately in conflict with gravitation because the expansion of the universe should decrease over 15 billions years due to grav-

itational attraction, rather than increase with the distance as per experimental data on cosmological redshifts; and other rather serious inconsistencies identified in the technical literature.

Similarly, it is known that “dark matter” is also a consequence of an additional adaptation of the dynamics of galaxies to special relativity. In fact, Santilli has shown that “dark matter” is a consequence of the assumption *within the dense gas* filling up the interior of galaxies of the speed of light *c in vacuum*, contrary to the evidence indicated in the preceding sections.

The conjecture of “dark matter” assumes unreassuring character when one meditates a moment on Santilli’s comment that, if uniformly distributed, “dark matter” cannot possibly have any measurable effects on the dynamics of stars. Consequently, “dark matter” must be placed ahead or behind a star to have its trajectory comply with the predictions of special relativity, but then the trajectory of a near-by star is outside these preferred prediction.

Similarly, Santilli has stressed that “dark energy” is yet an additional adaptation of physical evidence to special relativity, again, without any prior independent experimental backing. More specifically, Santilli has shown that “dark energy” is a consequence of the assumption of the speed of light *in vacuum* as the maximal causal speed in the *interior* of stars, quasars and black holes.

More specifically, Santilli has shown that the conjecture of “dark energy” is a consequence of the (generally tacit) assumption of the validity of Einstein’s equivalence law $E = mc^2$ for all possible conditions existing in the universe. The unreassuring condition is created by the fact that *Einstein formulated his equivalence law, specifically, for point-like particles*. Therefore, the applicability of the same equivalence law for the energy equivalence of stars, quasars and black holes is purely hypothetical.

It is then hoped the serious scholar will admit that astrophysics and cosmology cannot remain quantitative sciences without a *joint* study of ongoing far reaching conjectures based on the validity of special relativity everywhere throughout the universe as well as of *deviations* from special relativity for conditions beyond those originally conceived by Einstein.

In this section we shall review Santilli’s studies establishing the absence of the universe expansion, “dark matter” and “dark energy,” while jointly providing a rather momentous verification of the covering Santilli isorelativity.

In this section we review the same original references of the preceding section, namely, Santilli’s studies as summarized in his 1991 monographs [9, 10] (hereon referred to as “Santilli 1991”), Santilli’s contributed paper [124] at the 2007 ICDS conference in Bolu, Turkey (hereon referred to as “Santilli 2007”), and in the recent paper [130] (hereon referred to as “Santilli 2009”).

5.6.B Absence of universe expansion

Recall that the cosmological redshift z is defined by

$$z_{\text{cosm}} = f_{\text{emis}} - f_{\text{observ}}, \quad (5.133)$$

and it has been interpreted throughout the 20th century as being due to the (Doppler shift)_{cosm}

$$f_{\text{emis}} = \gamma^{-1} f_{\text{observ}} \approx 1 - \beta, \quad (5.134)$$

$$\gamma = (1 - \beta^2)^{-1/2}, \quad \beta = v/c, \quad (5.135)$$

where v is the expansion speed with respect to Earth, thus yielding the well known expression

$$z_{\text{cosm}} \approx \beta = v/c. \quad (5.136)$$

Santilli (1991, 2007, 2009) has pointed out that space can be considered as being empty only at short distances in astronomical scale, such as for interplanetary distances, while *space is indeed a physical medium at intergalactic distances*. In fact, the entire universe can be observed from any of its points. Hence, each point of intergalactic space is traversed by light originating from all of the universe, thus characterizing a local energy density d different than zero. Additionally, space is full of cosmic rays, hydrogen and matter that, again at intergalactic distances, contribute to space as being a physical medium with *cosmological speed of light and index of refraction* derived from the experimental evidence of Section 5.5

$$C_{\text{cosm}} = c/n_{\text{cosm}}(r, f, d, \dots). \quad (5.137)$$

The admission of the local character of the speed of light eliminates any need for the expansion of the universe. In fact, Santilli (2007) first assumes the limit case of no intergalactic motion at all,

$$v = v_{\text{exp}} = 0. \quad (5.138)$$

As a result, the cosmological redshift cannot any longer be interpreted as due to the Doppler's shift. However, by recalling the expression $\lambda f = C$, it is easy to see that the cosmological redshift can be numerically represented via the new law known as *Santilli cosmological isoredshift*

$$z_{\text{cosm}} = (c/\lambda)(1 - 1/n_{\text{cosm}}) \quad (5.139)$$

referred to a *redshift of light not due to relative motion*, but to the loss of energy to the medium due to interactions, with consequential decrease of the frequency.

As the reader knows, the prefix "iso" originating from Santilli's novel underlying mathematics and relativity known as *isotopies* in the Greek meaning of preserving the original axioms. As Santilli puts it: *Rather than abusing Einstein's name for personal gains, my way of honoring Einstein is by showing that*

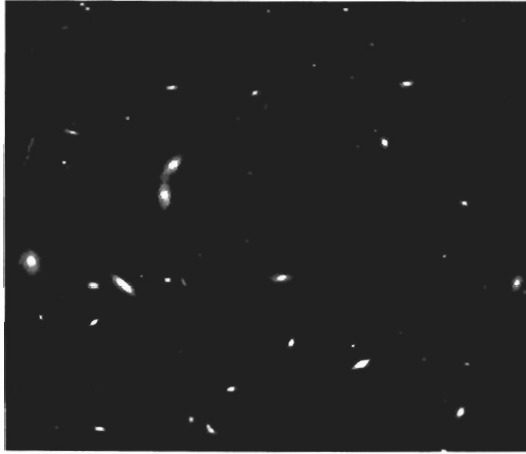

Figure 5.23. Santilli's innovative conception of intergalactic space is that of a medium with high energy density primarily characterized by light, with minor contributions from cosmic rays, hydrogen and dust. He argues that we can see the entire universe from any point in intergalactic space, thus implying that every point is crossed by light originating from the entire universe. Santilli has then eliminated the expansion of the universe by showing theoretically and experimentally (Section 5.5) that light propagating within a physical medium, in this case "light propagating through light," experience a redshift without any relative motion. Rather than adapting nature to a preferred theory, Santilli has adapted the theory to experimental evidence, by resolving in this way controversies of historical proportions.

his axioms admit a broader realization dramatically extending their original conditions of applicability.

Needless to say, the above cosmological isoredshift does not exclude small local expansions or contractions of the universe, as it is expected to be the case for the gravitational *repulsion* between matter and antimatter galaxies, and for the gravitational *attraction* between matter galaxies, respectively. However, expansions and contractions should be of such a minimal value and anisotropic character not implying the Middle Age belief that Earth is at the center of the universe.

It is evident that *Santilli cosmological isoredshift implies the expansion of the universe as well as the increase of the expansion with the distance.* To have an explicit illustration, Santilli introduces as a working assumption a simple functional dependence of the cosmological index of refraction of the type

$$n_{\text{cosm}} = 1/(1 - N r f d \dots), \quad (5.140)$$

where N is a positive constant, under which cosmological isoredshift becomes

$$z_{\text{cosm}} = (c/\lambda) N r f d \dots, \quad (5.141)$$

thus verifying *Hubble's law* for wavelengths essentially assumed as constant. We then have the following *structure model of Hubble's constant*

$$H_0 = (c/\lambda)N \approx 70 \text{ (km/sec) Mpc.} \quad (5.142)$$

Additionally, the model produces a dependence of the cosmological isoredshift on the frequency, wavelength, distance, energy density, temperature, and other characteristics.

Note that similar results can be obtained via Santilli isoredshift defined according to law (5.120). To understand the complexity of the model, one should keep in mind that, from the law $c = \lambda f$, the speed of light can decrease because of:

- 1) The decrease of the frequency only;
- 2) the decrease of the wavelength only; and
- 3) The decrease of both the frequency and the wavelength. Santilli's cosmological isoredshift is based in the latter case.

Finally, Santilli points out that the "big bang" conjecture does not provide a plausible explanation of the *background radiation* because of controversies in its emission, as well as the fact that, following some 15 billions years, the radiation emitted by the presumed primordial explosion can be proved to have been absorbed by galaxies.

By contrast, *Santilli cosmological isoredshift provides a quantitative representation of the background radiation*. In fact, a decrease of the frequency requires the necessary decrease of the energy of light:

$$\Delta E_z = E_{\text{emiss}} - E_{\text{observ}} = hf_{\text{emis}} - hf_{\text{oserv}} = (hc/\lambda)(1 - 1/n), \quad (5.143)$$

thus yielding a numerical representation of the continuous presence through times of the same background radiation since space cannot possibly absorb it.

In his 2007 paper, Santilli presents a detailed differentiation between his interpretation of the cosmological redshift and the numerous alternative interpretations known under the name of "tired light." A main differentiation is that the former is based on a structural lifting of special relativity, while the latter are based on special relativity and the reduction of light to photons traveling at the speed c . An additional interpretation is the admission in the former of a locally varying speed of light that is generally absent in the latter. A further difference is Santilli's innovative conception of *intergalactic space as a medium characterized by light*, while the notion of a medium is generally absent in "tired light" models.

5.6.C *Absence of "dark matter"*

The hypothesis of "dark matter" originated from an anomalous behavior of peripheral stars in a galaxy as compared to stars in its interior. But the only means for measurements of far away stars available on Earth is light. Therefore,

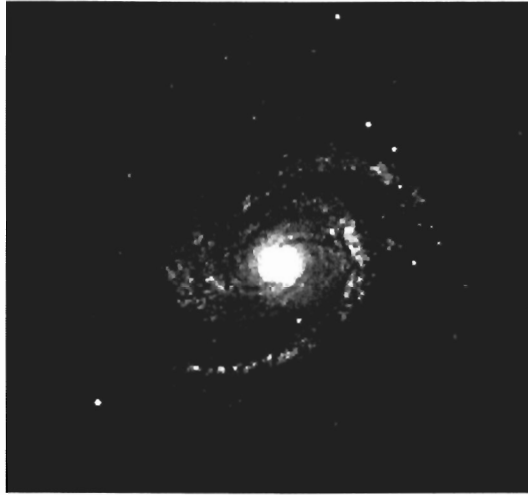

Figure 5.24. The 20th century astrophysics and cosmology assumed that interstellar space inside a given galaxy is empty so as to verify special relativity. Santilli (2007) pointed out that space within a galaxy is filled up with matter whose density decreases with the radial distance from the galactic center, thus causing a slowdown of the speed of light that decreases with the increase of said distance, by eliminating altogether the need for dark matter.

said anomaly is, again, derived from anomalous differences between the redshift of exterior and interior stars in a given galaxy.

Santilli (2007) pointed out that space within a given galaxy is indeed a physical medium, actually with much bigger energy density than intergalactic space. Therefore, the cosmological isoredshift applies for stars belonging to a galaxy, and he writes

$$C_{\text{galactic}} = c/n_{\text{galactic}}(r, f, d, \dots), \quad (5.144)$$

with *galactic isoredshift* for the case of stars having null radial speed with respect to Earth (e.g., as in Figure 5.23)

$$z_{\text{galactic}} = f_{\text{emiss}} - f_{\text{observ}} = (c/\lambda)(1 - 1/n_{\text{galactic}}). \quad (5.145)$$

The plot of the anomalous behavior of stars can be achieved via a plot of galactic index of refraction since it clearly varies with the distance from the galactic center.

It should be noted that stars belonging to a galaxy may have speeds toward and away from Earth. Additionally, galaxies and their interior media are highly anisotropic. Consequently, the general case of galactic dynamics requires specific studies per each galaxy and belongs to the field of *Doppler-Santilli isoredshift*, namely, a redshift due to a combination of a conventional redshift caused by relative motion and a complex isoredshift caused by physical media with locally varying densities.

5.6.D Absence of “dark energy”

Yet another reason for uneasiness in the astrophysics and cosmology of the 20th century is the rather widespread assumption of the validity of *Einstein’s equivalence principle*

$$E = mc^2, \quad (5.146)$$

throughout the universe, expectedly, until the end of time, without any scrutiny, thus adapting the universe to a preferred theory.

Needless to say, the equivalence principle is indeed valid for the conditions of its original conception and experimental verification, *point-like particles moving in vacuum*, such as particles in accelerators. However, the assumption of the same principle without any experimental evidence for *extended bodies* becomes a theology in Santilli’s view. Point particles have no dimension. Consequently, their maximal causal speed is the speed of light in vacuum c .

Consequently, the assumption of special relativity implies the *abstraction of the universe, including all its stars, quasars and black holes, to a set of isolated massive points*, with consequential universality of the speed of light and insufficient energy to explain its dynamics. At this point the need for an invariant, universal, covering relativity becomes crucial to prevent endless trials and errors. Recall from Section 3.10 the direct universality of Santilli’s isorelativity and the experimental evidence in particle physics, nuclear physics, astrophysics and other fields outlined in this chapter according to which the maximal causal speed within hyperdense matter (such as in the interior of hadrons, nuclei and stars) is *bigger* than the speed of light in vacuum, with consequential bigger values of the energy equivalence.

Recall also that the covering Lorentz-Poincaré-Santilli isosymmetry characterizes the *light isocone* (the light cone on Minkowski-Santilli isospace over the isofield, e.g., in the (3, 4)-space

$$\hat{x}^2 = x_3^2/n_3^2 - t^2c^2/n_4^2, \quad (5.147)$$

from which we have Santilli maximal causal speed, Eq. (3.95), i.e.,

$$V_{\max} = c(n_3/n_4). \quad (5.148)$$

Dark energy is then eliminated by merely noting that the *average maximal causal speed of the universe*, including the interior of stars, quasars and black holes, is expected as being much bigger than the speed of light in vacuum. As an illustration, the plot of experimental data on the structure of the neutron and the proton-antiproton fireball of the Bose-Einstein correlation yields the value $V_{\max} = 1.653c$ (Section 5.2). By recalling that black holes have a dramatically bigger density than that of the neutron or the proton-antiproton fireball, values much bigger than $1.653c$ are expected in the universe.

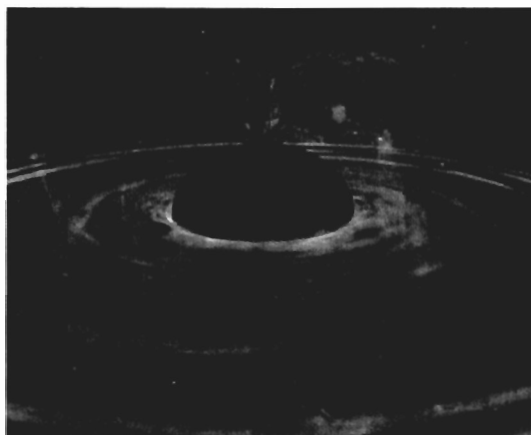

Figure 5.25. Santilli (2007) has shown that the current belief on “dark energy,” is a consequence of the belief that the speed of light c is a “universal constant,” thus being also valid in the interior of black holes depicted in this figure. The paradoxical character of these beliefs is that the lack of validity in the interior of gravitational collapse of conventional laws of physics is widely accepted in academia, thus eliminating the plausibility that the maximal causal speed in the interior of stars, quasars and black holes is the speed of light in vacuum. The admission of maximal causal speeds in the hyperdense interior of astrophysical bodies bigger than the speed of light in vacuum completely eliminates the conjectural belief of “dark energy,” as reviewed in the text.

To provide an initial but quantitative representation, by assuming n_s as the average of the three space characteristic quantities, the total energy of the universe is given by

$$E_{\text{tot}} = m_{\text{tot}} V_{\text{max, average}}^2 \quad (5.149)$$

The assumption of Santilli’s covering isorelativity allows an exact representation of the needed energy, the excess originating from the maximal causal speed in the interior of astrophysical bodies being bigger than c . In this case, Santilli writes the expression

$$E_{\text{“dark energy”}} = m_{\text{tot}} (V_{\text{max, average}}^2 - c^2). \quad (5.150)$$

The current estimate of the value of the dark energy can be used to provide an estimate of the average value of $V_{\text{max, average}}$ for the universe. For instance, assuming at the limit that the missing energy is 100-times the Einsteinian value, we get the estimate

$$V_{\text{max, average}} \approx 10c, \quad (5.151)$$

which is a rather reasonable value if one takes into account its limit character (100% excess energy), and the increasing number of black holes in the universe.

In short, rather than adapting the universe to verify a preferred theory, “dark energy” is a direct experimental evidence of the deviations of the universe from

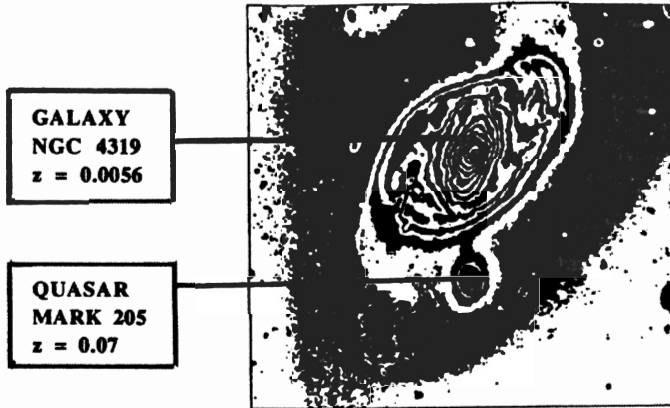

Figure 5.26. An example of clear astrophysical evidence beyond the capabilities of special relativity: the physical connection between the galaxy NGC 4319 and the quasar Mark 205 obtained by gamma spectroscopy, while their cosmological redshift of the galaxy is $z = 0.07$ and that of the galaxy is $z = 0.0056$. Any plausible interpretation of this difference requires a departures from special relativity, since the latter implies that physically connected astrophysical bodies must have the same speed. Santilli isoredshift provides a numerical representation of the above dramatically different cosmological redshifts, as outlined in the text.

special relativity, with particular reference to deviations from the universal character of the speed of light in vacuum as the maximal causal speed in favor of much bigger average values.

5.6.E Experimental verification with quasar redshifts

As it is well known, Halton Arp, a member of the Astrophysics Department of Harvard University, provided in 1987 (see for instance the monograph *Quasars Redshifts and Controversies*, H. Arp, Interstellar Media, Berkeley, 1987) experimental evidence that certain quasars are at rest with respect to their associated galaxies, even though their cosmological redshifts are dramatically different. Since such a view is at clear violation of Einsteinian doctrines, Arp experienced extreme academic obstructions, including the termination of his academic position at Harvard by his colleagues. In 1989, J. Sulentic (see, e.g., paper [155]) provided major astrophysical evidence of the correctness of Arp's view via gamma spectroscopy proving the existence of an actual physical contact between certain quasars and their associated galaxies, despite dramatic differences in their cosmological redshifts. The occurrence was more recently confirmed by other observations and it is now an astrophysical reality.

The following memoirs of 1988 [60] (see also Santilli 1991 for an update) proposed the isotopic interpretation of Arp-Sulentic data via isorelativity and iso-Minkowskian geometry. Santilli's main hypothesis was simply that light exits the

huge quasars chromospheres already redshifted due to the internal decrease of its speed c , according to the Doppler-Santilli isolaw invariant under the Lorentz-Santilli isosymmetry

$$f' \approx [1 - (v/c)(b_s/b_4)]f_0, \quad b_k = 1/n_k, \quad k = 1, s. \quad (5.152)$$

We are here dealing with an experimental verification beyond credible doubt of the local character of the speed of light, Santilli isoredshift of the preceding section, and Santilli isorelativity at large outlined in Section 3.10. According to special relativity, when a quasar and a galaxy are physically associated, they must have the same cosmological redshift. The clear experimental evidence that they have instead dramatically different redshifts is prove beyond credible doubt of *deviations* from special relativity in favor of a covering relativity.

Santilli's isorelativity provides a numerical representation of the indicated cosmological redshift. In essence, quasars have huge chromospheres at times as big as an entire galaxy. By contrast, galaxies have a relatively much more modest intergalactic gases. Therefore, the dramatically different cosmological redshifts establishes that *quasar light has been primarily redshifted during its travel within the quasar chromosphere*. By comparison, light has been minimally redshifted by the medium inside the galaxy. In this way, the light from the quasar and its associated galaxy reaches empty space dramatically redshifted to initiate their long intergalactic travel toward Earth.

In the 1992 paper [158] Mignani provided a direct experimental verification of the Doppler-Santilli isoredshift for the case of quasars that are associated to a galaxy according to clear gamma spectroscopy, yet the quasar and associated galaxy have a dramatically different cosmological redshift.

In essence, Mignani elaborated several data by Arp via the following relation for the cosmological redshift derived from the Doppler-Santilli isolaw (5.152)

$$\frac{b_s}{b_4} = \frac{[(\Delta f + 1)^2 - 1] \times [(\Delta f' + 1)^2 - 1]}{[(\Delta f + 1)^2 + 1] \times [(\Delta f' + 1)^2 + 1]} = B, \quad (5.153)$$

where $\Delta f'$ represents the isotopic redshift for the quasar and Δf represents the measured conventional redshift for the associated galaxy. The above values provide a clear confirmation of Santilli isorelativity and underlying isogeometrization of physical media. In fact, the data show that all values $B = b_s/b_4$ are positive and bigger than one, exactly as predicted.

The identification of the individual values b_s and b_4 requires at least one additional experimental measurement, such as the average speed of light $C = cb_4 = c/n_4$ in the quasar chromospheres. Such a value would fix b_4 . Then, b_s could be computed from the B -ratios. As an indication, the assumption for quasar UB1 of the average speed of light in its chromosphere $c = 0.80 \times c_0$ would yield the value $b_s = 40$.

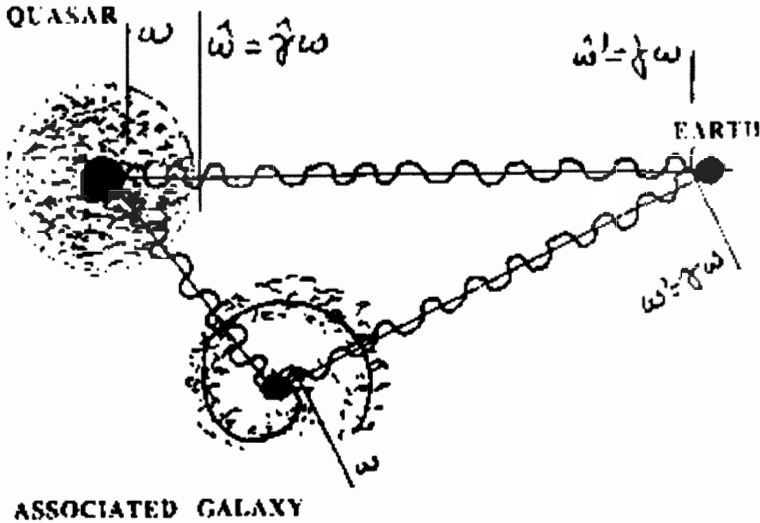

Figure 5.27. A reproduction of the original drawing by Santilli of 1988 illustrating the hypothesis on the isotopic origin of the quasar redshift, that is, a redshift due to the geometry of the huge quasars chromosphere. According to isorelativity, a first major component on the cosmological redshift of quasars is due to the decrease of the speed of light in its chromospheres. A second contribution is due to the anisotropy of the same medium. These two contributions then account for the complete difference in cosmological redshift between the quasars and the associated galaxy under the same relative speed v with respect to Earth.

GAL.	ω'_1	QUASAR	B	$\hat{\omega}_2$
NGC	0.018	UB1	31.91	0.91
		BSO1	20.25	1.46
NGC 470	0.009	68	87.98	1.88
		68D	67.21	1.53
NGC 1073	0.004	BSO1	198.94	1.94
		BSO2	109.98	0.60
		RSO	176.73	1.40
NGC 3842	0.020	QSO1	14.51	0.34
		QSO2	29.75	0.95
		QSO3	41.85	2.20
NGC 4319	0.0056	MARK205	12.14	0.07
NGC 3067	0.0049	3C232	82.17	0.53

Figure 5.28. The 1992 data by Mignani following Santilli 1988 hypothesis on the isotopic origin of quasar's cosmological redshift that provide a numerical, exact and invariant representation of the difference in cosmological redshifts between numerous quasars and their associates galaxies.

It should be noted that Mignani's calculations are based on the assumption of the expansion of the universe, and consequential conventional interpretation of the conventional Doppler's shift for light in vacuum. Following the experimental confirmation of Santilli's isoredshift outlined in the preceding section, Mignani's calculations should be revised for the complete reduction of the cosmological redshift to quasars and associated galaxies essentially at rest with respect to Earth in accordance with Section 5.6B.

In addition to the difference in cosmological redshifts between quasars and their associated galaxies when physically connected, quasars possess an *internal redshift and blueshift* that is a typical manifestation of the *dependence of the index of refraction on its frequency*.

The most plausible exact interpretation of the internal quasar redshifts and blueshifts known to the authors is that permitted by isorelativity and presented in the paper [89] via a dependence of the local index of refraction from the frequency of light of the type

$$n_4(f) = N_1 \times \exp[-N_2(f' - f)^2], \quad (5.154)$$

that provides an exact and invariant fit of Sulentic's experimental data.

In summary, according to Santilli's isorelativity, quasar cosmological redshifts and their internal red- and blue-shifts are due to interior physical characteristics of the quasars chromospheres and, more specifically, to their inhomogeneity and anisotropy, that is, to the *departures* from (rather than verification of) the geometry of empty space occurring within physical media. The understanding is that the fit of Figure 5.29 can ultimately result to be due to the contributions from the isoblueshift in the hyperdense interior of quasars, the isoredshift in the quasar chromosphere, and the isoredshift in intergalactic media.

5.7 Experimental Verification with Antimatter and Cosmology

5.7.A *The unreassuring condition of 20th century antimatter and cosmology*

As indicated in Chapter 1, antimatter caused one of the biggest scientific imbalances of the 20th century due to the lack of any *classical* treatment of antimatter, as a result of which matter was treated at all levels of study, from Newton to second quantization, while antimatter was solely studied at the level of second quantization.

This historical imbalance impacted in particular 20th century cosmology since the universe was widely assumed as being solely composed of matter. However, Santilli points out that evidence on the existence in the universe of antimatter stars is available on Earth. For instance, Santilli indicates that the 1927 Tunguska explosions in Siberia can solely be explained scientifically, that is, quantitatively,

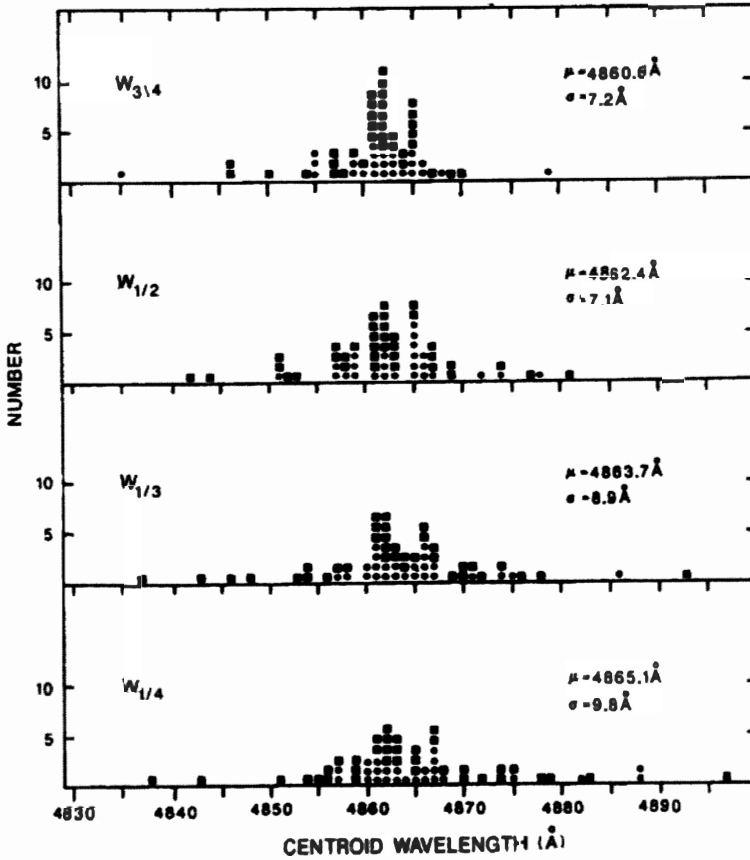

Figure 5.29. The numerical, exact and invariant fit of the experimental data by Sulentic on the quasars internal blue- and red-shifts done by Santilli via the use of isorelativity. The above interpretation is prohibited by the validity of special relativity within physical media, because the “universal constancy of the speed of light” prohibits a frequency dependence that is specific for locally varying speeds. In different words, isorelativity essentially reduces the quasars internal red- and blue-shifts to Newton spectral decomposition of light.

as being caused by an *antimatter asteroid*, due to the complete absence of any debris compared to the vastity of the devastation on the ground. In fact, *matter asteroid* leave an impact crater on the ground while it is impossible for them to evaporate completely.

Similarly, it is at times indicated that *antimatter cosmic rays* do not exist because they have not been detected on Earth. However, Santilli points out that only *matter cosmic rays* can reach Earth’s surface since all antimatter cosmic rays must annihilate in the upper region of our atmosphere. In fact, astronauts and cosmonauts indicate to have seen “flashes” of light in the upper atmosphere when in darkness.

Independently from all the above, a plausible act of creation of the universe would require a joint creation of matter and antimatter, e.g., in the event creation originated from energy. These and numerous additional aspects motivated Santilli to initiate a serious experimental study of antimatter at all levels.

5.7.B *Experimental verification of Santilli's isodual theory of antimatter*

As outlined in Chapter 3, Santilli has resolved the historical imbalance on antimatter by achieving the new isodual theory that permits the study of antimatter at all levels, from classical to operator mechanics, by restoring in this way a full democracy of study between matter and antimatter.

It is important for completeness to recall from Chapter 3 that *Santilli's isodual theory of antimatter verifies all known experimental data on antimatter*, because the Newton-Santilli isodual equations are anti-isomorphic to the conventional equations as requested by physical evidence, and the isodual map is equivalent to charge conjugation at the operator level. Additionally, the isodual theory of antimatter predicts *gravitational repulsion* between matter and antimatter and that light emitted from antimatter stars, referred to as *isodual light* or *isodual photon*, is different than that emitted by matter in an experimentally measurable form, as e.g., the isodual photon is predicted to be repelled in a matter gravitational field. Consequently, the isodual photon can be distinguished from an ordinary photon via accurate gravitational experiments on Earth measuring attraction or repulsion of light.

These important discoveries have created the previously missing *antimatter astrophysics and cosmology* whose scope is that of searching for antimatter stars, quasars and galaxies via the predicted *repulsion of isodual photons* by matter gravitational fields, and the study of similar predicted events. For more details, we refer the reader to Santilli's monograph [19].

5.7.C *Santilli's isoselfdual cosmologies*

Santilli's studies in cosmologies are the most difficult to understand on technical grounds because, in line his definition of "cosmology," they include all preceding advances. Therefore, the technical understanding on this section requires the knowledge of the all five volumes of HMMC [20–24]. Partial presentations can be found in the papers [96, 124].

An effective way to outline Santilli's cosmological studies is via the following statement he released for this volume:

The study of mathematics, physics and chemistry has been for me reason of great intellectual excitement in seeing simply magnificent constructions of the human mind, combined with great distress in seeing their misuse for conditions they

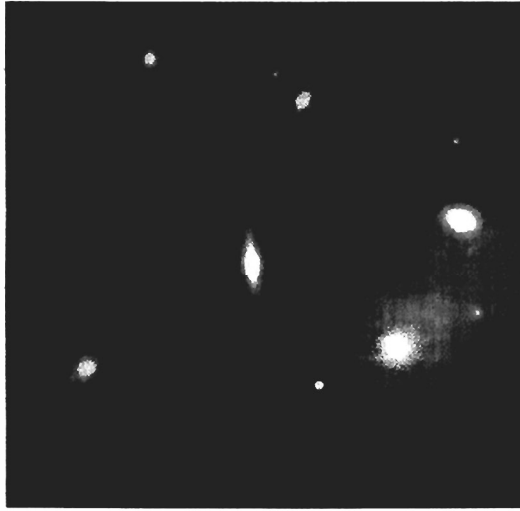

Figure 5.30. Santilli has defined “distressing” his studies of 20th century cosmology because of excessive assumptions, such as the expansion of the universe, “dark matter” and “dark energy,” intended to maintain the validity of Einsteinian theories under conditions they were not conceived, tested or intended for, rather than admitting their limitations, as well as the exclusion in cosmological models of biological structure and antimatter against the very Greek meaning of the word “cosmos.”

were not intended for. The first reason for intellectual excitement has been for me the majestic axiomatic structure of special relativity and its impressive experimental verifications for the conditions of its original conception (point-particles and electromagnetic waves propagating in vacuum), combined with great distress in seeing the application of the same theory under conditions vastly beyond those of its original conception without any serious scrutiny on evident limitations of the formalism, such as its local-differential character that limits the applicability to a finite set of isolated points.

Another reason for intellectual excitement has been for me the equally majestic axiomatic structure of quantum mechanics as well as its impressive experimental verifications for the same conditions recalled above, combined with great distress in seeing applications of quantum mechanics excessively beyond the conditions of original conception and verification, such as its widespread abuse for energy releasing process that are notoriously irreversible, thus not exactly treatment with a structurally reversible mechanics, such as quantum mechanics, or the application of the theory to biological structures despite their known complexity beyond our imagination at this time.

Similarly, I had great intellectual excitement in studying the Riemannian representation of gravity due to its beauty that has attracted so many colleagues, with great distress due to the absence in the technical literature of any serious study on

a number of insufficiencies, such as: the clear insufficiencies for interior gravitational problems compatible with other physical laws (e.g., thermodynamical laws); the impossibility to represent the free fall or our weight with curvature; not to mention structural problems in the time evolution due to curvature. In the final analysis, the sole known impossibility for curvature to allow any consistent grand unification and quantization of gravity constitutes pressing arguments to seek alternative theories of gravitation.

Yet, the most distressing studies have been for me those in 20th century cosmology. To begin, the Greek meaning of the word "cosmos" requires the inclusion of all creation. Therefore, I have difficulties in accepting the very name "cosmology" without at least a primitive treatment of biological structures and antimatter. As it is well known, both these fields were generally ignored in virtually all "cosmological" models of the 20th century, due to their primary intent to adapt the entire universe to Einstein special and general relativities.

My distress grew with the study of models that, even when restricted to matter, lacked any representation of the very important part of cosmology, the irreversible character of all interior gravitational problems for stars, quasars and black holes. More recently, my distress reached its climax when I realized that, rather than at least considering well known limitations of 20th century theories, true hyperbolas were voiced for the intent of adapting the universe to preferred theories.

The above series of distressing aspects forced me to conduct independent studies. The admission of interior non-Hamiltonian effects forced me to construct isomathematics, and then formate isomechanics and isochemistry reviewed earlier in this work. The inclusion of antimatter via their isodual images allowed the formulation of the **isoselfdual isocosmology (ISIC)** that, at the limit case of equal amount of matter and antimatter in the universe, is based on the following main axioms:

Isocosmological Axiom I: All events in the universe verify the direct product of the Lorentz-Poincaré-Santilli isosymmetry and for matter and its isodual for antimatter

$$\text{UniversalSymmetry} : \widehat{P}(3.1) \times \widehat{P}^d(3.1). \quad (5.155)$$

Isocosmological Axiom II: All events in the universe verify isorelativity for matter and its isodual for antimatter, thus including isogravitation.

Isocosmological axiom III: All total characteristics of the universe, such as time, mass, energy, momentum, etc. are identically null, thus avoiding a singularity at creation.

Main advances over conventional cosmological models are: the inclusion of antimatter; a more realistic treatment of interior problems; and the elimination of curvature in favor of the isoflatness of the Minkowski-Santilli isogeometry permitting a consistent grand unification as well as operator formulation of gravity; and

the resolution of the inconsistencies inherent in the expansion of the universe, "dark matter" and "dark energy."

Despite these advances, the insufficiencies of the isoselfdual isocosmology were for me as distressing as conventional models, evidently because of the lack of an axiomatically rigorous representation of irreversibility, as well as insufficiencies for the inclusion of biological structures.

In the hope of at least initiating the resolution of these limitations, I was forced to study the **isoselfdual genocosmology (ISGC)** based in the covering genomathematics with an ordering forward or backward in all operations, resulting in Lie-admissible/Jordan-admissible genomathematics, genomechanics and genochemistry for matter and their isoduals for antimatter.

A main advantage in passing from the isoselfdual isocosmology to the genotopic covering is the first known compatibility of interior gravitational problems with thermodynamic. in fact, being structurally irreversible, genomechanics is the first known mechanics directly compatible with all known thermodynamical laws.

Despite the advance, I remained distressed by the use of the word "cosmology" because of the inability to include biological structures due to insufficiencies of genomethods. An additional reason for distress was the absence of multivaluedness of the universe. In fact, as stressed in the technical literature of the field, any consistent classical representation of antimatter requires its formulation in a space coexistent with, but different than our spacetime. Consequently, the inclusion of antimatter in cosmological studies requires the use of multivalued hyperstructures in their simplest possible form, that characterized by the two valued hyperunit $I^f = (I^f, I^{fd})$. The transition from such a simple structure to a general multi-valued hyperstructure yields the **isoselfdual multivalued hypercosmology (ISMVHC)**.

It is important to recall here the inevitability of the ether as a universal substratum, and the characterization of matter as vibrations of the same in order to avoid the "ethereal wind" of the 19th century. The existence of different but coexisting multi-valued universes is then a question of admitting incoherent basic frequencies for matter belonging to one universe passing though matter belonging to another universe without interaction or mutual visibility. Note the insistence in the "multi-valued," rather than "multi-dimensional" character, according to which in the former case we have different universes all coexisting with our $(3 + 1)$ -dimensional spacetime, while in the latter case we have universes with dimensions of the generic type $(n + 1)$.

The advances permitted by ISMVHC are rather significant, because of the inclusion of biological structures treated in the most general known way, as well as matter and antimatter in their most general possible irreversible and multivalued formulation admitting as a particular case special relativity and its isodual for massive points propagating in vacuum.

To the best of my knowledge, the ISMVHC is the most general possible formulation of cosmology permitted by current mathematical, physical and chemical knowledge under the conditions of admitting a universal invariance (to prevent the Theorems of Catastrophic Inconsistencies of Noncanonical and Nonunitary Theories), and the formulation on a hyperfield, (to admit numerical predictions verifiable with experiments).

There is do doubt that, in view of such a vast structure, it may well take some time to surpass the ISMVHC via a broader formulation still admitting a universal invariance as well as applicability to experimental measurements. Yet, I believe that the complexities of the "cosmos" intended as encompassing all creation, are simply beyond our imagination at this writing. Consequently, short of the ascitic adaptation of new, hitherto unknown conditions to a preferred theory, I have no doubt that the ISMVHC will indeed require structural broadening at some future time.

In the final analysis, only artists such as Michelangelo, have produced eternal art. By comparison, we physicists can at best hope to have discovered one mere link in an open ended chain of links that will be continued until the end of mankind.

Appendix 5.A

Newton-Santilli Universal Gravitation

Santilli has repeatedly indicated in his writings that the bending of light by a matter star is entirely due to Newton's gravitation, and not to curvature of space. Alternatively, the representation of the bending via curvature in a Riemannian space leads to inconsistencies, e.g., inability to reproduce in first approximation Newton's attraction of light.

The above statement is generally obscure to physicists because Newton's attraction has been written since its inception in the 1687 *Principia* in the familiar form

$$F = g \frac{m_1 m_2}{r^2}, \quad (5.A.1)$$

where g is the familiar gravitational constant, which formulation has been applied over four centuries solely to *masses*, thus excluding *light* due to its massless character.

In his 2007 paper [124] Santilli has shown that *Newton gravitation is indeed "universal," thus including light*. This historically and scientifically important clarification has been reached via the following re-formulation of Newton's law, today called *Newton-Santilli universal gravitation*

$$F = s \frac{E_1 E_2}{r^2}, \quad (5.A.2)$$

where

$$s = g/c^4 \quad (5.A.3)$$

is the new gravitational constant.

In essence, Santilli has shown that the gravitational field is not originated by mass m , but by its energy $E = mc^2$. As an illustration, Santilli points out that the source in the Einstein-Hilbert gravitational field equations is given by the "energy-momentum" tensor, and not by the "mass-momentum" tensor, and that the insistence in the use of the mass as origin of the field leads to various inconsistencies.

Once the origin of the gravitational field is identified with the energy, rather than the mass, it is evident that gravitation is indeed universal, thus attracting matter as well as light. In fact, a given light with photon energy $E_1 = hf$ is attracted by

a matter star with energy $E = E_2 = mc^2$ according to the Newton-Santilli law

$$F = s \frac{hfE}{r^2}. \quad (5.A.4)$$

The proof that the bending of light is entirely of Newton-Santilli character is then elementary. Despite its simplicity, the implications of Santilli's universal re-formulation of Newton's gravitation are indeed momentous, such as:

1) The Newton-Santilli gravitation removes the historical motivation for the assumption that space is actually curved as assumed by Einstein himself. It is hoped interested historians may study the case and clarify whether Einstein did actually believe that Newton's gravitation excluded light, thus not being universal, or Einstein was motivated by other reasons.

2) Newton-Santilli gravitation predicts that the isodual light emitted by an antimatter star is repelled by a matter star and vice-versa. In fact, under isoduality, the energy of a photon becomes *negative* although referred to a *negative unit of energy*, according to the law

$$F = s \frac{(-hf)E}{r^2}, \quad (5.A.5)$$

thus allowing the initiation of *antimatter astrophysics* that was absent in the 20th century.

3) The Newton-Santilli law of universal gravitation requires a structural revision of a number of additional beliefs in the 20th century astrophysics and cosmology. As shown in Section 5.5, *Einstein energy equivalence has been solely established for massive points moving in vacuum under the maximal causal speed c* . For extended astrophysical bodies, we expect maximal causal speed (3.95), i.e.,

$$V_{\max} = cn_3/n_4 = Cn_3, \quad C = c/n_4. \quad (5.A.6)$$

Santilli's energy equivalence is then given by

$$E = mC^2n_3^2, \quad (5.A.7)$$

where n_3 can be assumed to have the value 1 in first approximation. The important point is that in the interior of astrophysical bodies, the value C is, in general, much bigger than c , and the space characteristic functions are bigger than one. Consequently, *the gravitational field predicted by the Newton-Santilli law for a given mass is much bigger than that predicted by Newton's or Einstein's gravitation*.

To illustrate the far reaching implications, it is sufficient to indicate that *the Newton-Santilli law requires a revision of the numerical values of the masses of the constituents of the Solar system*. As pointed out by Santilli in the above quoted paper, this is due to the fact that the trajectories of planets in the Solar

system have been computed with Newton's law. Since these trajectories cannot be altered, the reinterpretation of Solar data via the Newton-Santilli law requires a revision of the masses, generally expected to be lower than their currently assumed value.

It is hoped this appendix provides additional illustrations of the momentous implications of Santilli studies.

Appendix 5.B

Lie-isotopic and Lie-admissible scattering theories

The climax of the applications and experimental verifications of hadronic mechanics is given by the nonunitary Lie-isotopic and Lie-admissible generalizations of the quantum mechanical, unitary scattering theory. As expected by experts in hadronic mechanics, the Lie-isotopic scattering theory holds for *reversible* scatterings while the broader Lie-admissible scattering theory holds for *irreversible* scatterings.

In particular, one should know that the new scattering theories do not or cannot change quantities that are actually measured, such as scattering cross section, scattering angles, etc. nevertheless, the new scattering theories generally produce final experimental values different than those of quantum mechanics in view of *different elaborations* of said measured quantities.

These studies are under way and their status at this writing (December 2010) is identified in great details in Refs. [132] [133] [134] [135]. The main idea is that during the phase of acceleration of particles in accelerators, special relativity and quantum mechanics apply in full because we have point particles moving in vacuum under action-at-a-distance, potential-Hamiltonian interactions.

However, when passing to high energy collisions, accelerated particles penetrates within other particles or within nuclei, thus experiencing inevitable contact nonpotential, and non-Hamiltonian interactions due to deep mutual penetration of their wavepackets and/or charge distributions. The non-Hamiltonian character of the latter interactions then demands the scattering theory as being nonunitary. Hadronic mechanics then uniquely applies because it is the only known theory capable of achieving an invariant formulation of nonunitary interactions, besides being directly universal for all possible interactions considered.

The issue as to whether the Lie-isotopic scattering theory for reversible processes can provides final experimental values departing from those of the conventional unitary scattering theory, is unknown at this writing. i Nevertheless, it is known that the Lie-isotopic theory permits a significant broadening of the field with the inclusion of event outside 20th century scatterings, such as the synthesis of neutrons from protons and electrons, the synthesis of π^0 mesons from electrons and positrons, and other reversible events with an intrinsic nonunitary structure (see Chapter 6 for details), thus being outside the representational capabilities of quantum mechanics..

Significant deviations from the potential - unitary scattering theory are expected for the case of inelastic scattering represented via the Lie-admissible theory since inelastic scatterings are strictly irreversible over time, while the conventional scattering theory is fully reversible. Under these conditions, the appropriate generalization of 20th century scattering theory and the proper interpretation of the results should indeed be subject to scientific debate, but the denial of its need would be a clear attempt at scientific manipulations for personal gains..

Chapter 6

REDUCTION OF MATTER TO PROTONS AND ELECTRONS

6.1 Introduction

6.1.A Foreword

Hadronic mechanics has been conceived, built and verified to achieve one of the biggest syntheses in scientific history: the reduction of matter to protons and electrons. Santilli's view is that stars initiate their lives as being solely composed of hydrogen; they first synthesize neutrons from protons and electrons; and then they synthesize all elements existing in nature. Therefore, a consistent interpretation of the neutron as a bound state of a proton and an electron under a generalized mechanics ensures the achievement of the indicated reduction.

The first major difficulty facing said reduction, whose solution required decades of research, is that quantum mechanics prohibits the neutron from being a bound state of a proton and an electron for numerous reasons studied in this chapter, such as the impossibility of representing the spin, rest energy, magnetic moment, charge radius, and other features of the neutron.

Santilli has shown that quantum mechanics is exactly valid for the dynamics of the proton and the electron when at the large mutual distance of the hydrogen atom, in which case only potential and, therefore, Hamiltonian interactions occur with their well known unitary time evolution. By contrast, Santilli has shown that quantum mechanics is *inapplicable* (rather than being "violated") for the conditions of total mutual penetration of the electron within the hyperdense medium inside the proton.

In fact, the latter conditions imply the emergence of fundamentally new interactions of contact, nonpotential and non-Hamiltonian type that, as such, require a generalized mechanics with a nonunitary time evolution (evidently in view of

its non-Hamiltonian character). This is a main motivation for the proposal, construction and verification of hadronic mechanics as a nonunitary covering of quantum mechanics.

Another major difficulty in the achievement of the indicated reduction is the rather general belief that the neutron is a bound state of particles, known as quarks, that cannot be directly detected, yet are popularly believed as being real particles in our spacetime, thus obstructing alternative views. However, as Santilli puts it:

It has been impossible for me to believe that, at the time of the synthesis of the neutron inside a star, the permanently stable proton and electron simply “disappear” from our universe to be replaced by the hypothetical quarks, and then, at the time of the neutron decay, the proton and the electron simply “reappear” by academic fiat. Rather than conjecturing the existence of hypothetical particles for the evident purpose of maintaining the validity of a preferred theory inside hadrons, I elected instead to adapt the theory to nature and represent the neutron as a generalized bound state of a proton and an electron which is quantitatively possible when admitting their condition of total mutual penetration, with resulting non-Hamiltonian, thus nonunitary time evolution.

In essence, Santilli fully accepts $SU(3)$ -color theories, also called the “standard model,” as providing the final *Mendeleev-type classification of hadrons into families*; he accepts quarks as being necessary for the elaboration of $SU(3)$ theories; but he considers quarks what they technically are, purely mathematical representations of a unitary symmetry that cannot be even defined in our spacetime; and has established a basically novel structure models of hadrons with physical constituents in such a way to reach full compatibility with the $SU(3)$ classification.

A main objective of this chapter is to review the scientific process that lead to the exact and invariant representation of *all* characteristics of the neutron as a generalized bound state of a proton and an electron in conditions of total mutual penetration that, as such, cause their lifting into generalized particles described by hadronic mechanics and its basic isosymmetries.

The structure of nuclei parallels that of the neutron. In fact, nuclei were originally conceived as bound states of protons and electrons because, as recalled above, all nuclei originate from hydrogen. Subsequently, it became known that such a nuclear conception is prohibited by quantum mechanics. The achievement of an exact representation of the neutron as a bound state of a proton and an electron under the laws of hadronic mechanics automatically assures the reduction of nuclei to protons and electrons.

Additionally, Santilli has shown that such a representation is necessary for the exact representation of numerous basic nuclear data left unresolved by quantum mechanics, such as the spin 1 of the deuteron, the stability of the neutron in

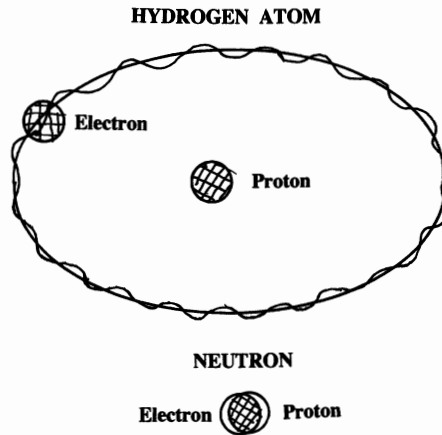

Figure 6.1. An original drawing used by Santilli in his lectures to illustrate the dramatic physical differences between the hydrogen atom and the neutron synthesis from a proton and an electron as occurring in stars. In the former case, the large mutual distance allows an effective point-like abstraction of the proton and the electron, resulting in the exact validity of quantum mechanics. In the latter case, the use of the same abstraction causes the exiting from the boundary of science in favor of theologies due to the condition of total penetration of the electron within the hyperdense medium inside the proton, with the resulting inapplicability of quantum mechanics due to the emergence of contact non-Hamiltonian forces that are basically absent in the hydrogen structure.

certain but not all nuclei, the nuclear force, and other aspects. Needless to say, the current representation of nuclei as a quantum mechanical bound state of protons and neutrons does remain valid, but only as a first *approximation* of a much more complex physical reality.

Rather than being mere academic semantic, the reduction of nuclei to protons and electrons has rather serious social, let alone scientific, relevance because, as shown in the next chapter, it allows the conception and industrial development of basically new clean energies called *hadronic energies*, rather than nuclear energies, because originating from mechanisms in the structure of hadrons, rather than in their collection (as it is the case for known nuclear energies). As a matter of fact, this chapter is a pre-requisite for the new clean energies studies in the next chapter.

In this chapter we shall solely use the *Lie-isotopic, time reversible branch of hadronic mechanics* because the neutron synthesis is reversible over time, thus not requiring the broader, irreversible, Lie-admissible mechanics. For simplicity we shall use the ordinary associative multiplication $A \times B = AB$ of generic quantities A , B , and avoid the use of the multiplication symbol “ \times .” This essentially means that the presentation of this chapter deals with the “projection” of the various models in our spacetime. The understanding is that the axiomatically correct

formulation is solely that on isospaces over isofields and related isotopic product as presented in Chapter 2.

To prevent the “impression” of criticisms that in reality have no scientific ground, readers with a vast knowledge of quantum mechanics but insufficient knowledge of the covering hadronic mechanics are suggested to acquire a minimal technical knowledge of the preceding presentations prior to venturing judgments on the content of this chapter.

6.1.B *Santilli’s recollections on the birth of hadronic mechanics*

Hadronic mechanics was technically born with my 1967–1968 papers on the Lie-admissible and Jordan admissible mutation (deformation) of Lie algebras and, consequently, of Heisenberg’s equation, that were part of my Ph. D. studies at the University of Torino, Italy, [32] and other papers of that period such as [33, 34].

In August of 1967 I moved with my family to the USA where I soon realized that it would have been impossible for me to locate an academic job based on Lie-admissible and Jordan-admissible research since these algebras were unknown at that time in the U. S. mathematics, let alone physics. Hence, I dedicated myself to more mundane research that can be identified in my curriculum, even though i continued the study of Lie-admissible and Jordan-admissible covering theories.

When I joined the Lyman Laboratory of Physics at Harvard University in September 7, 1977, during the very day of my arrival, I was invited by ERDA, soon to become the the DOE, to apply for the grant number ER-78-S-02-47420.A000. During my conversations with Dr. David Peaslee, the ERDA-DOE officer in charge of my grant, I was told the DOE preference, originated from the final days of Carter’s Administration, to conduct “innovative studies on new clean energies and fuels.”

*Therefore, I plunged myself in the study of what I consider the biggest reservoir of clean energy available to mankind, the **neutron**. In fact, the neutron is naturally unstable and decays into a proton, a highly energetic electron whose energy can be easily captured with a metal shield and the innocuous neutrino (if it exists).*

Along these lines, it became mandatory to initiate the study with the synthesis of the neutron as it occurs in stars, that is, as a “compressed hydrogen atom” according to Rutherford’s original conception of 1920.

*However, I immediately stumbled into a major technical problem. Schrödinger’s equation is consistent for well known quantum mechanical bound states, those with a **negative binding energy**, as it is established for nuclear, atomic and molecular bound states. By comparison, the synthesis of the neutron **requires** 0.782 MeV energy (in which case there is no energy left for the hypothetical neutrino...).*

I remember trying the impossible, day and night, to solve the Schrödinger equation with a "positive binding energy" to have completely inconsistent and, in any case, physically meaningless equations.

Eventually, I had to accept the inapplicability of quantum mechanics for the synthesis of the neutron from a proton and an electron as occurring in stars. I also discovered that the problem was rather general, inasmuch as quantum mechanics was inapplicable for the synthesis of all hadrons from massive particles produced in their spontaneous decays with lowest mode, inapplicability that signaled the lack of acceptance of important alternatives in particle physics of the 20th century, such as the so-called "boot-strap model."

*At that point, I initiated the search for alternatives mechanics with the predictable outcome that **physically consistent solutions for a "positive binding energy" are only possible under a "nonunitary image" of Schrödinger's equation. That signaled the conception, as well as the name of "hadronic mechanics" as currently known.***

Before joining the Lyman Laboratory of Physics at Harvard University, I had been a member of the Department of Physics at MIT during which stay I had the opportunity of several pleasant scientific contacts with its chairman of the time, Herman Feshback, one of the world leaders of Schrödinger's equation with particular reference to its application in nuclear physics.

In early 1978, I called Herman asking for a meeting he kindly granted. On arrival at his office at MIT, I told Herman my inability to solve the Schrödinger equation for the neutron synthesis by saying "Herman, am I gone banana, or there is a real structural problem in this case?" Herman confirmed his deep knowledge of the field by immediately saying "Ruggero, the indicial equation of Schrödinger's equation has no physical solution for a bound state in which the total energy is bigger than the sum of the rest energies of the constituents."

In this way, I did have a confirmation that I was not gone banana and that the synthesis of the neutron was indeed a fundamental open problem of 20th century physics because beyond the class of unitary equivalence of quantum mechanics. Therefore, I said "Herman, your statement is indeed correct and remains valid under the most general possible unitary class of equivalence of quantum mechanics. However, you may be interested in knowing that I have apparently found physically consistent solutions via a nonunitary image of Schrödinger's equation."

At the hearing of that statement, Herman Feshback behavior changed dramatically; he left his desk; called me "Dr. Santilli;" and gave me the clear hint that the meeting was over. Therefore, I quickly left after saying thanks. I clearly understood that, at that point, I lost an academic friend due to his evident attachment to quantum mechanics, but I had gained something much more important, the awareness of the far reaching importance of the synthesis of the neutron.

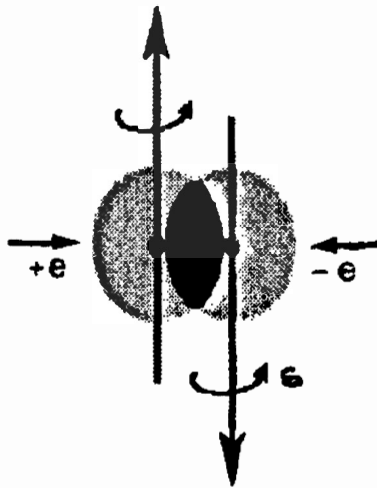

Figure 6.2. A schematic view of the main interactions absent in the structure of the hydrogen atom, but present in the neutron synthesis of Figure 6.1, the nonlinear, nonlocal and nonpotential interactions due to deep wave overlapping of extended particles. Their non-Hamiltonian character mandates a nonunitary covering of quantum mechanics. This motivated the birth of hadronic mechanics in Spring 1978.

Since that meeting, Herman Feshback became one of my worst academic enemies in the Cantabridgean area, as I reported and documented in [5]. However, I want to express here my appreciation to Herman Feshback because of his crucial role in one of the most important scientific consultations of my life.

On my way back to Harvard, I plunged myself full speed into the study of the most general possible nonunitary image of quantum mechanics. By using nonunitarity transforms of the 1967–1968 Lie-admissible and Jordan admissible equations, it was easy to reach the most general possible lifting of Schrödinger and Heisenberg equations for open irreversible and non-Hamiltonian processes.

*Due to the primary application of the covering theory to the synthesis of the neutron and of other hadrons, I suggested the name of **hadronic mechanics** for the class of invariant nonunitary images of quantum mechanics, and proposed its construction in the two memoirs of 1978 under the indicated ERDA-DOE contract [43, 44].*

In Section 5 of the second memoir I solved completely the nonunitary image of Schrödinger's equation for the synthesis of the π^0 meson from the positronium. However, I could not even initiate the solution of the synthesis of the neutron due to numerous technical problems yet to be solved, including the isotopies of the $SU(2)$ -spin symmetry, the achievement of invariance of numerical predictions over time, and other problems.

Preliminary maturity for the synthesis of the neutron was first reached at the nonrelativistic level in the 1990 paper [62, 66] and at the relativistic level in the JINR memoir [82] published in [90].

Nevertheless, these studies still lacked invariance over time that was finally achieved in the 1997 memoirs for reversible and irreversible processes, respectively, [99, 100].

I outlined this laborious scientific journey in my monographs [20–24]. Among various independent studies, a nice review dedicated to the neutron is that by Jerdsay Kadeisvili in the memoir [197].

6.1.C New structure model of unstable hadrons and leptons

In the two memoirs, hereon referred to as 1978A and 1978B [43, 44], Santilli proposed a *new structure model of unstable hadrons and leptons* based on the following:

ASSUMPTION 1: Conventional quantum mechanics is exactly valid in the exterior problem of hadrons in vacuum resulting in a linear, local-differential and potential-Hamiltonian characterization of particles solely as being point-like;

ASSUMPTION 2: The size of wave packets and/or charge distributions of all particles is of about 1 fm. This establishes that hadronic constituents are in conditions of total mutual penetration, with consequential emergence of nonlinear, nonlocal-integral and nonpotential/non-Hamiltonian forces and the validity of the covering hadronic mechanics for interior structural problems;

ASSUMPTION 3: The constituents of unstable hadrons and leptons are conventional massive particles that can be produced free in the spontaneous decays;

ASSUMPTION 4: When immersed within a hadronic medium, constituents experience an alteration (called *mutation*) of all intrinsic characteristics as characterized by the the Lorentz-Poincaré-Santilli isosymmetry, and recover conventional characteristics when released free in vacuum;

ASSUMPTION 5: the number of elementary massive physical constituents of unstable hadrons and leptons increases with the increase of the mass as it is the case for nuclei, atoms and molecules.

In this chapter, we shall outline the new structure models by following its original derivation. To begin, in Section 5 of 1978B, Santilli initiated his new structure model with the lightest meson, the π^0 , by recalling that it decays spontaneously into an electron and a positron

$$\pi^0 \Rightarrow e^- + e^+. \quad (6.1)$$

Hence, Santilli assumed that the π^0 is a bound state of one mutated electron (isoelectron) \hat{e}^- and one mutated positron (isopositron) \hat{e}^+ (called in the original work *eleton* and *antieleton*) according to hadronic mechanics (hm),

$$\pi^0 = (\hat{e}^-, \hat{e}^+)_{\text{hm}}, \quad (6.2)$$

by showing that it provides an exact representation of *all* characteristics of the particle considered, such as rest energy, meanlife, charge radius, charge, electric and magnetic moments and parity, including the primary decay

$$\pi^0 \Rightarrow 2\gamma, \quad (6.3)$$

that is an evident confirmation of the assumed structure. Other decays (such as $e^-e^+e^-e^+$, $e^-e^+\gamma$, etc.) are caused by secondary processes, thus requiring hadronic field theory that is not studied in this chapter.

In the same memoir 1978B, Santilli noted that the π^\pm meson admits the decay

$$\pi^\pm \Rightarrow \pi^0 + e^\pm + \gamma. \quad (6.4)$$

Therefore, he assumed that the π^\pm is a bound state of the mutated meson (isomeson) $\widehat{\pi}^0$ and the isoelectron \widehat{e}^\pm , namely, it has *three* conventional, massive, elementary constituents with

$$\pi^\pm = (\widehat{\pi}^0, \widehat{e}^\pm)_{\text{hm}} \approx (\widehat{e}^-, \widehat{e}^\pm, \widehat{e}^+)_{\text{hm}} \quad (6.5)$$

along Assumption 5 on the increase of the number of massive physical constituents with mass (or energy), while keeping the approximate charge radius of 1 fm.

In order to prevent the impression of having valid criticisms, the reader should be aware that the spin zero of the π^\pm is represented *exactly* by the isosymmetries of hadronic mechanics, while being impossible for quantum mechanics. Hence, the study of the Lie-Santilli isotherory is suggested prior to venturing comments, due to the novelty of the field.

Note also that hadronic mechanics permits *the reduction of a three-body to a two-body structure*, thus allowing a full exact analytic solution similar to that achieved later on by Santilli and Shillady on the hydrogen structure (Chapter 4). Again, the various other decays of the π^\pm require the use of the hadronic field theory. Next, Santilli solved in Section 5 of the paper 1978B the structure model of the remaining mesons of basic $SU(3)$ multiplets that will be reviewed in Section 6.2.

Along similar lines, Santilli noted that the μ^\pm leptons admit the spontaneous decay

$$\mu^\pm \Rightarrow e^- + e^\pm + e^+ \quad (6.6)$$

and showed that the structure model

$$\mu^\pm = (e^-, e^\pm, e^+)_{\text{hm}} \quad (6.7)$$

provides a representation of *all* characteristics of the muons, as well as the compatibility with the meson decay

$$\pi^\pm \Rightarrow \mu^\pm + \gamma + \nu. \quad (6.8)$$

The existence of bound states (6.2) and (6.7) with the same number of elementary constituents but different values of the total angular momentum is a confirmation of the existence of two classes of irreducible representations of the isotopic $\widehat{SU}(2)$ -spin symmetry, called *regular and irregular isorepresentations*, essentially characterized by the preservation or mutation of conventional spin eigenvalues, respectively.

Following decades of extensive and solitary study on the achievement of full maturity of the Lie-isotopic theory and quantum mechanics, as reviewed in the five monographs hereon referred to as HMMC [20–24]. Santilli reached a non-relativistic exact representation of the neutron synthesis from a proton and an electron as occurring in stars, first presented in the 1990 paper [62], see also the paper [66] he wrote while visiting the *International Center for Theoretical Physics* in Trieste, Italy.

In essence, Santilli noted that the neutron admits the spontaneous decay (when isolated)

$$n \Rightarrow p^+ + e^- + \nu. \quad (6.9)$$

Hence, he showed that the structure model of the neutron as a bound state of a mutated proton (isoproton) and an isoelectron

$$n = (\widehat{p}^+, \widehat{e}^-)_{\text{hm}} \quad (6.10)$$

provides an exact and invariant representation of *all* characteristic of the neutron, as well as its spontaneous decay.

The complete relativistic solution was reached by Santilli while visiting the *Joint Institute for Nuclear Research* in Dubna, Russia, in the 1993 paper [82] that was subsequently published in China [90].

Again, the possible perception of “errors” in model (6.10) may be a manifestation of insufficient knowledge of the field. In fact, the notorious inability to reach the spin 1/2 of the neutron is solely valid under the abstraction of the proton and the electron as dimensionless points, which abstraction is manifestly questionable when the electron is totally immersed within the hyperdense medium inside the proton. By contrast, when particles are admitted as being extended and, when in condition of total mutual penetration, are characterized by the covering Lorentz-Poincaré-Santilli isosymmetry, the spin 1/2 of the neutron is represented *exactly* in model (6.10) as reviewed in Section 6.3. As a matter of fact, this is the very aspect that required decades of research, including the prior construction of a covering of all branches of Lie’s theory.

In the subsequent memoir of 1997 [99] Santilli also showed that the principles of the new structure model of unstable hadrons with conventional massive constituents applies to unstable baryons. For instance, the Λ baryon admits the

decays

$$\Lambda \Rightarrow p^+ + \pi^-, \quad (6.11)$$

$$\Lambda \Rightarrow n + \pi^0. \quad (6.12)$$

Therefore, he proved that the new structure model

$$\Lambda = (\widehat{p}^+, \widehat{\pi}^-)_{\text{hm}} \approx (\widehat{n}, \widehat{\pi}^0)_{\text{hm}} \quad (6.13)$$

represents *all* characteristics of the Λ baryon, as well as both decays in (6.11), (6.12), the remaining decays requiring hadronic field theory.

In the same 1997 memoir, Santilli worked out the new structure model for additional baryons and showed the compatibility of his structure models of mesons and baryons with known $SU(3)$ classifications, as reviewed in the subsequent sections.

The above models are today known as *Santilli structure models of hadrons and leptons*, or *hadronic structure models* for short, where the term “hadronic” indicates the use of hadronic mechanics.

The understanding of the new structure model under consideration requires a technical knowledge of the equivalence of the two models in Eq. (6.13), since this equivalence is at the very basis of the notion of isoparticles and, therefore, directly related to the basic isosymmetries.

6.1.D Inapplicability of quantum mechanics to the structure of hadrons

Recall that the conventional *Schrödinger equation* at the foundation of quantum mechanics

$$\left[-\frac{\hbar^2}{2m} \Delta + V(r) \right] \psi(r) = E\psi(r) \quad (6.14)$$

is *exactly valid* for the structure of the hydrogen atom because it represented all experimental evidence in a numerically exact way. This historical achievement was due to the large mutual distance between the proton and the electron allowing their good point-like approximation with consequential sole existence of action-at-a-distance interactions derivable from a potential, and related binding energy.

In Santilli’s view, the Schrödinger equation is *inapplicable* (rather than being “violated”) for the structure of hadrons and leptons for numerous insufficiencies identified in 1978B (see also HMMC Vol. IV). Let us consider the energy data of the two main hadronic structure models (6.2) and (6.10), that is, for the π^0

$$\pi^0 = (\widehat{e}^-, \widehat{e}^+)_{\text{hm}}, \quad (6.15)$$

$$E_{\pi^0} = 134.976 \text{ MeV}, \quad E_e = 0.511 \text{ MeV}, \quad (6.16)$$

$$\Delta E = E_{\pi^0} - 2E_e = +133.959 \text{ MeV}, \quad (6.17)$$

and for the neutron

$$n = (\widehat{p}^+, \widehat{e}^-)_{\text{hm}}, \quad (6.18)$$

$$E_n = 939.565 \text{ MeV}, E_p = 938.272 \text{ MeV}, E_e = 0.511 \text{ MeV}, E_\nu = ?, \quad (6.19)$$

$$\Delta E = E_n - (E_p + E_e) = +0.782 \text{ MeV}. \quad (6.20)$$

Santilli has established that the Schrödinger equation is inapplicable to the above structure models for the following reasons:

1) All consistent quantum mechanical bound states $A + B = C$, as they occur in nuclei, atoms and molecules, have a *mass defect*, namely, the rest energy of the bound state C is *smaller* than the sum of the rest energies of the original states A and B , resulting in the very principle for which nuclear fusions release energy. The above mass defect is represented by a *negative binding energy* in the Schrödinger equation (6.14) for the bound state that, under these conditions, is fully consistent. By comparison, in structures (6.15) and (6.18), the rest energy of the final state is *bigger* than the sum of the rest energies of the constituents. As a result, any possible treatment of the structures would require a *positive binding energy* that is anathema for quantum mechanics because, in this case, the Schrödinger equation becomes physically inconsistent, without any known possibility of achieving solutions with the usual procedures of adding unknown parameters and the like, for the scope of adapting nature to a preferred theory.

2) It is popularly believed that the missing energy can be provided by the relative kinetic energy between the massive physical constituents. This view has no serious scientific content, because the cross section of the constituents at the missing value of the energy is extremely small (of about 10^{-30} barn for the pion) in which case the probability for the constituents to coalesce and form the hadron is essentially null.

3) Assuming that, via hitherto unknown manipulations, incompatibilities 1) and 2) could be resolved, simple calculations via the use of quantum mechanics show the impossibility of a quantitative representation of the meanlife of the hadron, since under the indicated conditions the hadron would decay 10^{10} times faster than the measured time.

4) Quantum mechanics does not allow the achievement of the spin $1/2$ of the neutron via two particles, the proton and the electron, each having spin $1/2$. As shown in Section 6.3, the Pauli-Fermi hypothesis of the emission of the neutrino in the neutron synthesis is far from being settled, e.g., because the mechanism for a neutron to “decompose” itself and produce the neutrino is vastly unknown, since Fermi’s weak interactions provide an *external* description without detailed structural content.

5) Assuming that all the above incompatibilities (that are per se irreconcilable on serious scientific grounds) are somewhat resolved, quantum mechanics cannot represent the magnetic moment of the neutron from the known magnetic moments of the proton and the electron.

6) When facing the missing 0.782 MeV for the neutron synthesis, a rather popular approach is that of considering the complementary hypothesis of the *anti-neutrino* according to the reaction



and assuming that the missing energy is provided by the antineutrino. Santilli has pointed out that this popular belief has no serious scientific foundations because the antineutrino has a virtually null cross section with the proton and the electron. Consequently, there is no possibility that the antineutrino can deliver the 0.782 MeV needed for the neutron synthesis.

7) Santilli has additionally shown, e.g., in the paper [98] that, to achieve democracy in the treatment of matter and antimatter, the anti-neutrino has to be interpreted as having a negative rest energy referred to a negative unit of energy. In this case, full democracy is regained between matter and antimatter, but the antineutrino in Eq. (6.21) *requires* energy for its existence, rather than releasing it.

In summary, in numerous cases of particle physics (such as the proton-antiproton annihilation of the Bose-Einstein correlation, and many other processes indicated in Chapter 5), supporters of quantum mechanics as the final theory of nature can manage to add unknown parameters, change equations with unknown functions fitted from the data, and do other procedures to claim that “quantum mechanics is valid.” However, this manipulation of scientific knowledge is impossible for the synthesis of the neutron as well as of all hadrons at large because no matter what manipulation is conceived, no quantitative representation of all characteristics of the neutron and the other hadrons is possible via quantum mechanics.

6.1.E *The dichotomy: classification vs structure of hadrons and leptons*

As stated in the original memoirs 1978A and 1978B, in the memoir [48] of 1981, in the more recent paper [98] and in various additional works (see HMMC, Vol. I for a general review and references), *Santilli accepts the SU(3)-color Mendeleev-type classification of hadrons as being final; he recognizes that quarks are necessary for the technical elaboration of SU(3) theories; but he identifies quarks with their technical definition, namely, as purely mathematical representations of a purely mathematical internal unitary symmetry defined in a purely mathematical, complex-valued internal unitary space.*

Consequently, *Santilli does not accept that quarks are physical particles* for the following reasons:

1) There is no technical possibility for defining quarks in our spacetime, e.g., because of known technical incompatibilities with the Lorentz-Poincaré symme-

try, with consequential impossibility *a priori* for quarks being physical particles in our spacetime.

2) As recalled earlier, quark conjectures require that, at the time of the synthesis of the neutron inside stars, the permanently stable proton and electron “disappear” from our universe to be replaced by hypothetical quarks and then, at the time of the spontaneous decay of the neutron, the proton and the electron simply “reappear” in our universe. Santilli believes that these views are implausible and merely based on the intent of preserving the validity of quantum mechanics inside hadrons (because the hypothetical quarks are assumed as having a hypothetical point-structure, thus being sued to maintain the validity of quantum mechanics).

3) Assuming that the above problems can be somewhat bypassed, Santilli has provided a rigorous proof that *quarks cannot have gravity* because, according to Einstein, gravity can solely be defined in our spacetime while quarks cannot. Consequently, in the event protons and neutrons were made up of quarks, gravity could not exist in the universe.

4) Santilli has additionally proved that the so-called “quark masses” are pure mathematical parameters thrown into the equations to adapt nature to a preferred theory, because *quarks cannot have inertia* since they cannot be characterized via the second-order invariant of the Lorentz-Poincaré symmetry. In the absence of a scientifically proved inertia, the notion of “quark masses” is essentially a theology.

5) Santilli has additionally disproved claims of “quark confinement” by using Heisenberg’s uncertainty principle, that establishes the existence of a finite probability for free isolated quarks in dramatic disagreement with experimental evidence. This inconsistency is essentially due to the assumption of the exact validity of quantum mechanics in the outside as well as the inside of hadrons under which assumption no model can possibly render identically null the transition probability from interior to exterior states.

In Santilli’s view, the biggest obstacles against the development and utilization of the energy contained in the neutron is the widespread belief that hypothetical, directly undetectable and permanently confined quarks are physical constituents of the neutron and of hadrons at large.

In the event such a conjecture is correct, and quarks are physical constituents of the neutron, no possibility exists or is conceivable for the utilization of the energy in its interior because quarks have to be assumed as being permanently confined, while all known nuclear, atomic and molecular energies are based on the capability of extracting the constituents and turning them free. On the contrary, if the electron is indeed a physical constituent of the neutron even in a mutated form, said energy can indeed be utilized, as we shall see in Chapter 7, via its stimulated decay.

Among all available alternatives to bypass the above problematic aspects, Santilli's solution proposed since 1978B (but ignored by numerous particle physicists to their peril) appears as being the most plausible one, namely, *assume the standard model as the final Mendeleev-type classification of hadrons and construct a basically new model for the structure of individual hadrons of a given $SU(3)$ family under the condition, as it was the case for nuclei, atoms and molecules, that the structure model achieves compatibility with the classification.*

For the case of atoms, the transition from the Mendeleev classification to the atomic structure required the transition from classical mechanics to a new discipline, quantum mechanics. Due to the hyperdense character of the medium inside hadrons, the transition from the classification of hadrons to the structure of individual hadrons requires the transition this time from quantum mechanics for exterior conditions of point-like particles to the covering hadronic mechanics for interior conditions of extended particles in conditions of total mutual penetration.

Recall that the isotopic branch of hadronic mechanics with Lie-Santilli isoproduct $[A, B] = ATB - BTA$ is *directly universal for all closed isolated systems*, irrespective of whether with solely Hamiltonian or Hamiltonian and non-Hamiltonian internal forces, and that the genotopic branch of hadronic mechanics with Santilli Lie-admissible product $(A, B) = ARB - BSA$ in its single-valued and multi-valued hyperstructural realizations (Chapter 2) are *directly universal for all known open-irreversible systems*, thus including as particular cases isotopic and quantum theories.

Consequently, the assumption of broader non-Hamiltonian interactions for the structural problem renders hadronic mechanics uniquely and unambiguously applicable due to its direct universality, invariance over time, and covering characters. Therefore, claims that alternative generalizations of quantum mechanics (such as the so-called deformations of quantum mechanics proposed by Santilli in 1967) are "new" require the hardly achievable proofs of their novelty with respect to hadronic mechanic, equal invariance over time and covering character.

6.2 Reduction of Mesons and Leptons to Electrons and Positrons

6.2.A Conception of the π^0 structure

As recalled in Section 6.1C, Santilli conceived in memoir 1978B the π^0 as a *compressed positronium*, namely, as a bound state of one electron and one positron at 1 fm mutual distance since such a conception naturally explains the charge radius of the π^0 , its very small meanlife (since electrons and positrons annihilate each other), its spontaneous decay

$$\pi^0 \Rightarrow 2\gamma \text{ (98.79\%)} \quad (6.22)$$

as well as its secondary decay

$$\pi^0 \Rightarrow e^+ + e^-, \quad (6.23)$$

where the first decay is expected from annihilation, the second decay is expected as a tunnel effect of the constituents, and the remaining decays are interpreted as their mixture or higher order processes.

Note that the electron and the positron are permanently stable massive particles, unless they annihilate each other. Consequently, Santilli argued that the most plausible hypothesis is that the electron and the positron are the physical constituents of the π^0 , namely, decays (6.23) is a form of tunnel effect of the massive constituents.

The hypothesis essentially implies that the infinite quantum states of the positronium admit one single additional energy level at 1 fm distance, the π^0 . However, it is well known that quantum mechanics prohibits such an additional bound state. Moreover, in early 1978, Santilli had discovered the impossibility for Schrödinger equation to admit physically meaningful solutions when the rest energy of the bound state is bigger than the sum of the rest energies of the constituents, Eqs. (6.16), for which very reason Santilli proposed the construction of the covering hadronic mechanics.

Hence, Santilli conceived the π^0 as being created in the transition from the positronium (pos) verifying quantum mechanics (qm), to a new bound state at the distance of 1 fm under total mutual penetration of the wavepackets of the constituents, the π^0 , verifying the covering hadronic mechanics (hm), thus including the necessary singlet coupling to avoid the repulsive forces in triplet couplings for particles inside each other

$$\text{pos} = (e_{\downarrow}^+, e_{\uparrow}^-)_{\text{qm}} \Rightarrow \pi^0 = (\widehat{e}_{\downarrow}^+, \widehat{e}_{\uparrow}^-)_{\text{hm}}. \quad (6.24)$$

Santilli realized since the early stages that, when in conditions of total mutual penetration of their wavepackets, electrons and positrons cannot be the same as when isolated in vacuum under sole long range electromagnetic interactions. He then assumed that the electron and the positron acquire a mutated form \widehat{e}^- and \widehat{e}^+ called in memoir 1978B *eleton* and *antieleton*, respectively, although the names of *isoelectron* and *isopositron* became later on more widely used due to their characterization via isosymmetries.

Still in early 1978, Santilli also argued that the conditions of mutual penetration of the constituents implies the presence of new contact, nonlinear, nonlocal and nonpotential forces that cannot possibly be represented with a Hamiltonian. This led to the conception of hadronic mechanics as a nonunitary covering of quantum mechanics and this naturally led Santilli to the quantitative representation of the “compression of the positronium” via the nonunitary map

$$\pi^0 = U(e^+, e^-)_{\text{qm}} U^\dagger = (\widehat{e}^+, \widehat{e}^-)_{\text{hm}}, \quad UU^\dagger \neq I. \quad (6.25)$$

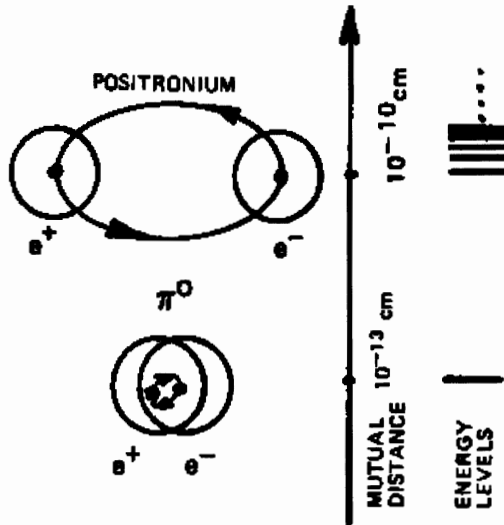

Figure 6.3. A reproduction of an original figure used by Santilli in 1978 to illustrate his model of the π^0 particle as "compressed positronium," namely, as consisting of one single additional bound state of the positronium under conditions of total mutual penetration of the constituents at 1 fm mutual distance verifying the covering hadronic mechanics. Santilli then showed that the model represents the totality of the characteristics of the π^0 , including rest energy, meanlife, charge radius, charge, spin, parity, magnetic moment and main decays.

Recall that the Schrödinger equation for the positronium represents *all* characteristics of the state considered. Along the same lines, Ref. 1978B proved that *one single nonunitary image of Schrödinger equation represents the totality of the characteristic of the π^0 .*

In this section we outline Santilli's structure model of the π^0 with physical elementary constituents and the main lines of the structure models for the remaining mesons and (unstable) leptons, as well as their compatibility with known $SU(3)$ classifications. Regrettably, we cannot possibly review the exact analytic solution due to its advanced mathematical character. Interested readers are suggested to study Section 5 of memoir 1978B that remains the most comprehensive presentation of the topic to this day (see also the detailed review in HMMC, Vol. IV).

6.2.B Structure equation of the π^0

Recall again that the Schrödinger equation for the positronium provides a numerically exact representation of *all* characteristics of the bound state considered. Consequently, *Santilli considers a generalized equation as truly representing the*

“structure” of “one” given hadron if and only if it represents the “totality” of the characteristics of the hadron considered.

Other studies, such as the representation of *only the mass* of a hadron as part of a spectrum of masses including those of other hadrons, even though scientifically valuable, have no connection with the content of this section because, in Santilli’s view, they treat the Mendeleev-type classification of hadrons and *not* their structure.

In the historical memoir 1978B, Santilli implemented as follows the above conception. Consider the Schrödinger equation for the positronium with electron mass m , charge $-e$ and state $|e\rangle = |e(t, r)\rangle$:

$$H|e\rangle = \left(\frac{p^2}{m} - \frac{e^2}{r}\right)|e\rangle = \left[-\frac{\hbar^2}{m}\Delta - \frac{e^2}{r}\right]|e\rangle = E|e\rangle, \quad (6.26)$$

$$p|e\rangle = -i\hbar\partial_r|e\rangle. \quad (6.27)$$

The image of the above equations under a nonunitary transform is given by the following basic rules of hadronic mechanics

$$UU^\dagger = \hat{I}(t, r, p, \dots) = 1/\hat{T}(t, r, p, \dots) \neq I, \quad \hat{I} > 0, \quad (6.28)$$

$$U(H|e\rangle)U^\dagger = (UHU^\dagger)(UU^\dagger)^{-1}(U|e\rangle U^\dagger) = \hat{H}\hat{T}|\hat{e}\rangle = E'|\hat{e}\rangle, \quad (6.29)$$

$$U(p|e\rangle)U^\dagger = (U_pU^\dagger)(UU^\dagger)^{-1}(U|e\rangle U^\dagger) = \hat{p}\hat{T}|\hat{e}\rangle = -iU(\partial_r|e\rangle)U^\dagger = -i\hat{\partial}_r|\hat{e}\rangle = -i\hat{I}\partial_r|\hat{e}\rangle, \quad (6.30)$$

where $|\hat{e}\rangle = |\hat{e}(t, r)\rangle$ represents the wavefunction of the isoelectron, $\hat{\partial}_r$ represents the isoderivative (Chapter 2), one should keep in mind that the eigenvalue E' is *different* than the original value E , and \hbar is generally omitted in the equations of hadronic mechanics because absorbed by the isounit.

By using Eq. (6.30), Eq. (6.29) can be explicitly written

$$\left(-\frac{1}{m}\hat{p}\hat{T}\hat{p}\hat{T} + V_{\text{Coulomb}}\right)|\hat{e}\rangle = E'|\hat{e}\rangle, \quad (6.31)$$

$$V_{\text{Coulomb}} = -\frac{e^2}{r}, \quad (6.32)$$

where one should note the absence of the isotopic element \hat{T} between the Coulomb potential and the state $|\hat{e}\rangle$ since, at this nonrelativistic level, the charge is not mutated and the Coulomb potential acts as a scalar (not so at the relativistic level as shown in the next section). As a result, nonunitary transform (6.29) solely acts as follows

$$U\left(-\frac{e^2}{r}|e\rangle\right)U^\dagger = -\frac{e^2}{r}U|e\rangle U^\dagger = -\frac{e^2}{r}|\hat{e}\rangle. \quad (6.33)$$

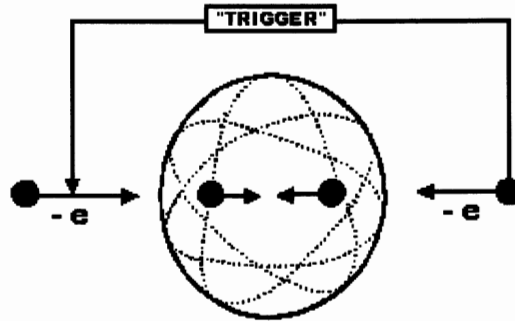

Figure 6.4. A conceptual rendering of Santilli’s “trigger” consisting of an external action (such as collision, pressure, etc.) forcing particles to pass through the “hadronic horizon” (the sphere of radius 1 fm) with consequential activation of strongly attractive forces discussed in the text.

Note that, as it is the case for the synthesis of the neutron and of all hadrons, the positronium does not naturally perform the transition to the π^0 particle unless there is an external action, called by Santilli the “trigger,” such as collision, impact, external forces, or other means. For the case of the synthesis of the π^0 , Santilli represented the trigger with the *Hulten potential*

$$V_{\text{Hulten}} = K \frac{\exp(-r/R)}{1 - \exp(-r/R)}, \tag{6.34}$$

where K is a constant and R represents the charge radius of the considered state, resulting in the following structure equation

$$\left(-\frac{\hat{I}^2}{m} \Delta + V_{\text{Coulomb}} + V_{\text{Hulten}} \right) |\hat{e}\rangle = \left(-\frac{\hat{I}^2}{m} \Delta - \frac{e^2}{r} - K \frac{\exp(-r/R)}{1 - \exp(-r/R)} \right) |\hat{e}\rangle = E|\hat{e}\rangle. \tag{6.35}$$

When compared to Eq. (6.26), Eq. (6.35) clearly illustrates a central feature of hadronic mechanics, the lifting of Planck’s constant \hbar into Santilli isounit

$$\hbar \Rightarrow \hat{I}(t, r, p, \dots). \tag{6.36}$$

This is necessary to avoid implausible assumptions, such as the belief that an electron in the core of a star has the same quantized energy levels as when moving isolated in vacuum as a member of an atomic structure.

However, the Hulten potential is known to behave at short distances like the Coulomb potential. Therefore, Santilli assumed the following good approximation

in the interior of the hadronic horizon

$$V_{\text{Hulten}} + V_{\text{Coulomb}} \approx N \frac{\exp(-r/R)}{1 - \exp(-r/R)}, \quad (6.37)$$

namely, the Hulten potential "absorbs" the Coulomb potential at short distances resulting in a mere change of the constant, from the original value K to the new value N .

Additionally, Santilli noted that, unlike the case of point particles at large mutual distances, *the most stable orbit for extended particles under conditions of mutual penetration is the circle*. Alternatively, it is easy to see that elliptic orbits cause the exiting of the hadronic horizon, with consequential return to a fully quantum state. This property allowed the additional good approximation

$$m' = \frac{m}{|\widehat{I}^2|} = \text{constant}, \quad (6.38)$$

where $|\widehat{I}^2|$ stands for absolute or average value of \widehat{I}^2 .

Hence, in Section 5 of memoir 1978B, Santilli reached the following *structure model of the π^0 meson as a hadronic bound state of one isoelectron and one isopositron*

$$\left(-\frac{1}{m'}\Delta - N \frac{\exp(-r/R)}{1 - \exp(-r/R)} \right) |\widehat{e}\rangle = E' |\widehat{e}\rangle, \quad (6.39a)$$

$$\text{Rest energy: } E_{\pi^0} = E_{\widehat{e}^-} + E_{\widehat{e}^+} - |E'| = 135 \text{ MeV}, \quad (6.39b)$$

$$\text{Meanlife: } \tau_{\pi^0}^{-1} = 4\pi |\widehat{e}(0)|^2 \alpha E_{\widehat{e}} = 10^{16} \text{ sec}, \quad (6.39c)$$

$$\text{Charge radius: } R_{\pi^0} = 1 \text{ fm} = 10^{-13} \text{ cm}, \quad (6.39d)$$

$$\text{Magnetic and electric moments: } M_{\pi^0} = 0, \quad (6.39e)$$

$$\text{Charge: } C_{\pi^0} = 0, \quad (6.39f)$$

$$\text{Charge parity: } P_{\pi^0} = +, \quad (6.39g)$$

$$\text{Space parity: } S_{\pi^0} = -, \quad (6.39h)$$

where one should remember our assumption that \hbar is absorbed in the isounit (see memoir 1978B for explicit expressions).

As we shall see in the next section, *the single equation (6.39) achieved for the first time in scientific records the numerically exact and time invariant representation of all characteristics of the π^0 meson, as necessary for a true model of structure*. As we shall also see, this historical achievement is permitted by the nonunitary character of hadronic mechanics combined with novel short range interactions due to total mutual penetration of the wavepackets of the constituents.

Note that the Hulten potential in Eq. (6.39a) is conventional, thus negative in value. Consequential, Eq. (6.39a) could not possibly represent the total energy

of 135 MeV of the π^0 with 0.511 MeV constituents due to the inconsistency of the Schrödinger equation under these conditions recalled earlier. Consistency is restored by the *renormalization of the rest energy* (6.38) that renders Eq. (6.39a) consistent, as shown below.

In summary, *Santilli proposed in memoir 1978B the construction of hadronic mechanics as a nonunitary covering of quantum mechanics, identified in the same memoir the main dynamical equations, and established the necessity of the new mechanics as the sole permitting a consistent representation of all characteristics of the π^0 meson.*

Since 1978, model (6.39) has been re-derived in various alternative ways by several authors always resulting in Eq. (6.39a) as final structural model. We here present the following alternative derivation.

Recall that, in first approximation, the elementary charge e is not assumed as being mutated in the above nonrelativistic hadronic treatment. However, *all characteristics of particles are mutated at the relativistic hadronic level, thus including the elementary charge*, as necessary from the Lorentz-Poincaré-Santilli isosymmetry (see Section 6.3). Consequently, the elementary charge can indeed be considered as being mutated at the nonrelativistic level too, $e \Rightarrow e'$, and, in lieu of Eq. (6.33), we introduce the following lifting

$$U \left(\frac{-e^2}{r} |e\rangle \right) U^\dagger = -U \left(\frac{e'^2}{r} \right) U^\dagger (UU^\dagger)^{-1} U |e\rangle U^\dagger = -\frac{e'^2}{r} \hat{T} |\hat{e}\rangle, \quad (6.40)$$

in which case the hadronic structure equation can be written

$$\left(-\frac{1}{m} \hat{p} \hat{T} \hat{p} - \frac{e'^2}{r} \right) \hat{T} |\hat{e}\rangle = E' |\hat{e}\rangle, \quad (6.41)$$

For general consistency, Santilli isounit must have the structure (with $\hbar = 1$)

$$\hat{I} = 1/\hat{T} = \exp[-F(r) \int \hat{e}_\uparrow^\dagger(r) \hat{e}_\downarrow(r) d^3r], \quad (6.42)$$

when $F(r)$ is a well behaved positive-definite function, since the above realization verifies the following conditions:

- 1) Representation of deep mutual penetration of the wavepackets of particles at distances of 1 fm;
- 2) Presence of novel nonlinear, nonlocal-integral and non-potential interactions represented by the isounit, rather than the Hamiltonian; and
- 3) Recovering of quantum mechanics uniquely and identically outside the hadronic horizon thanks to the limit (with $\hbar = 1$)

$$\lim_{r > 1 \text{ fm}} \hat{I} = 1, \quad (6.43)$$

We then introduce, apparently for the first time, the following realization of the isounit

$$\hat{I} = 1/\hat{T} = \exp[(-V_{\text{Hulten}}/V'_{\text{Coulomb}}) \int \hat{e}_\uparrow^\dagger(r)\hat{e}_\downarrow(r)d^3r], \quad (6.44)$$

that, to first order, can be written

$$\hat{I} \approx 1 - V_{\text{Hulten}}/V_{\text{Coulomb}}, \quad (6.45)$$

$$\hat{T} \approx 1 + V_{\text{Hulten}}/V_{\text{Coulomb}}, \quad (6.46)$$

It is then easy to see that the replacement of value (6.46) in Eq. (6.41) recovers Eq. (6.35), hence, Eq. (6.39), identically,

$$\begin{aligned} \left(-\frac{1}{m}\hat{p}\hat{T}\hat{p} + V'_{\text{Coulomb}}\right)\hat{T}|\hat{e}\rangle &= \left(-\frac{1}{m}\hat{p}\hat{T}\hat{p}\hat{T} + V'_{\text{Coulomb}}\right)\left(1 + \frac{V_{\text{Hulten}}}{V_{\text{Coulomb}}}\right)|\hat{e}\rangle = \\ &= \left(-\frac{\hat{I}^2}{m}\Delta + V_{\text{Coulomb}} + V_{\text{Hulten}}\right)|\hat{e}\rangle = E'|\hat{e}\rangle. \end{aligned} \quad (6.47)$$

The minus sign in the exponent of isounits (6.42), (6.44) has a truly crucial function deserving a mention. Recall that Planck's constant \hbar is positive-definite but much smaller than one. Since hadronic mechanics is an axiom-preserving isotopy of quantum mechanics, the isounit must equally be positive-definite but smaller than one,

$$|\hat{I}^2| > 0, \quad |\hat{I}^2| < 1. \quad (6.48)$$

Consequently, the renormalization rest energy (6.38) is much bigger than the conventional energy, i.e.,

$$m' = \frac{m}{|\hat{I}^2|} \gg m. \quad (6.49)$$

This is the mechanism, first identified by Santilli in 1978B, turning an inconsistent Schrödinger equation into a consistent form because, as shown in the next section, the value of $2m'$ is bigger than 135 MeV, thus allowing the indicial equation to have physically meaningful solutions.

6.2.C Solution of the π^0 structure equation

The representation of features (6.39e) to (6.39h) is trivial for all structure models of the π^0 as a bound state of a particle and its antiparticle. However, it should be clarified that, as requested by the very topology and differential calculus at the foundation of quantum mechanics, the constituents of hadrons must be point-like. Consequently, quantum mechanics predicts an equal probability for both singlet and triplet bound states.

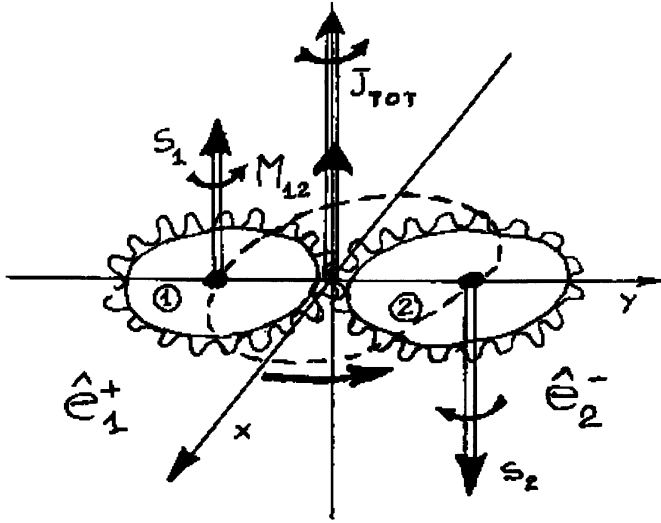

Figure 6.5. A reproduction of Fig. 2, page 852, of memoir 1978B depicting the “gear model” used to illustrate the general law of hadronic mechanics according to which, when in conditions of mutual penetration of the wavepackets and/or of the charge distributions, only singlet couplings of spinning particles are stable, while triplet couplings are highly unstable. In fact, gears can only be coupled in singlet, as shown in the figure, while their triplet coupling implies high repulsive forces. Note that this law does not exist for quantum mechanics since the particles in this case are dimensionless points, thus allowing both singlet and triplet couplings.

In memoir 1978B, Santilli achieved the unique representation of the spin 0 of the π^0 by showing that *the sole stable bound state of extended particles in conditions of total mutual penetration is singlet couplings*, due to extreme repulsive forces existing in the corresponding triplet coupling, and illustrated this occurrence with the so-called “gear model” (see the Figure 6.5).

Consequently, Santilli restricted the analytic solution to Eqs. (6.39a) to (6.39d) reduced to their radial form (where we restore the use of Planck’s constant for clarity)

$$\left[\frac{1}{r^2} \frac{d}{dr} r^2 \frac{d}{dr} + \frac{4\pi^2 m'}{h^2} \left(E' + N \frac{\exp(-r/R)}{1 - \exp(-r/R)} \right) \right] |\hat{e}\rangle = 0, \tag{6.50a}$$

$$2E_{\hat{e}^-} - |E'| = 135 \text{ MeV}, \tag{6.50b}$$

$$2\lambda^2 |\hat{e}(0)|^2 \alpha E_{\hat{e}^-} / h = 10^{16} \text{ sec}, \tag{6.50c}$$

$$R = 10^{-13} \text{ cm}, \tag{6.50d}$$

where Eqs. (6.50b) to (6.50d) are not subsidiary constraints of Eq. (6.50a), but verified by the latter.

As it is well known from nuclear physics, Eq. (6.50a) admits the typical energy spectrum of the Hulthen potential

$$E = - \left(\frac{\beta^2}{n} - n \right)^2 \frac{N}{4\beta^2}, \tag{6.51}$$

$$\beta^2 = \frac{4\pi^2 m' N R^2}{h^2}, \tag{6.52}$$

$$n = 1, 2, \dots, M, \tag{6.53}$$

where M is the maximal integer value in $\beta^2 n$ so that zero is lowest value of $|E'|$. Note that *the Hulthen potential has a finite number of admissible energy levels, as it is well known.*

Santilli then introduces two parameters k_1 and k_2 defined as follows

$$E_{\hat{e}} = k_1 hc/R = h^2/2m'R^2 \tag{6.54}$$

$$m'VR^2/h^2 = k_2 = 1 + \varepsilon, \quad 0 \leq \varepsilon \leq 1, \tag{6.55}$$

the latter relation originating from the boundary conditions. In this case, the wavelength of the isoelectron becomes

$$\lambda = R/2\pi k_1, \tag{6.56}$$

thus being very small, and the Hulthen constant can be written

$$N = k_2 h^2/m'R^2 = 2k_2 E_{\hat{e}} = 2E_{\hat{e}}, \tag{6.57}$$

thus being very large. The latter property establishes the strength of the hadronic interactions. In terms of the above parametrization, Santilli reached the following equations for the energy and the meanlife

$$E_{\pi^0} = 2E_{\hat{e}} - |E'| = 2k_1 [1 - (k_2 - 1)^2] hc/R = 135 \text{ MeV}, \tag{6.58}$$

$$2R^2 |\hat{e}(0)|^2 \alpha E_{\hat{e}} / 2\pi k_1 h = 10^{16} \text{ sec.} \tag{6.59}$$

Following due analytic process, the set of structure equations (6.50) is then reduced, rather remarkably, to the following *algebraic solution* in the k -parameters (see 1978B, Eq. (5.1.32), page 840)

$$k_1 \times [1 - (k_2 - 1)^2] = E_{\pi^0} R/2hc, \tag{6.60}$$

$$(k_2 - 1)^3/k_1 = 48 \cdot 137^2 R/4\pi c\tau_{\pi^0}, \tag{6.61}$$

with numerical results

$$k_1 = 0.34, \tag{6.62}$$

$$k_2 = 1 + 4.27 \times 10^{-2}. \quad (6.63)$$

The following comments are now in order:

1) **Invariant representation of all π^0 characteristics.** As one can see, Santilli reached in 1978B the exact representation of all the characteristics of the π^0 with physical, that is, directly detectable massive constituents, a mutated electron (isoelectron) and a mutated positron (isopositron), including the exact representation of all intrinsic characteristics of the particle and constituents and of spontaneous decay (6.22), (6.23). The representation of the remaining spontaneous decays is based on second order effects, such as annihilation or pair creation *in the interior of the π^0* , thus requiring the hadronic quantum field theory under development at this writing.

By comparison, the structure model of the π^0 as a bound state of a quark and an antiquark does indeed represent the rest energy, but as one element of a mass multiplet thus linking the structure of the π^0 to those of the remaining mesons of a given $SU(3)$ multiplet. Such a characterization cannot possibly provide the joint representation of the meanlives of all members of the same multiplet, while the size of each meson remains essentially unaddressed. We therefore have a model similar to the classification of a family of atoms without any information for their quantized energy emissions and their size, with evident insufficiencies. Additionally, mesons are strongly interacting particles, thus experiencing gravity while, as indicated earlier, quarks cannot have gravity because they cannot be consistently defined in our spacetime. Moreover, the electron and the positron are believed as being “created” at the time of decay (6.23) although without a detailed quantitative representation, again, because quarks are solely defined in interior complex-values spaces, while electrons and positrons are solely defined in our spacetime. The conceptual, mathematical, physical and experimental advantages of Santilli’s structure model of the π^0 over quark conjectures are then evident.

Besides the representation of all features of the π^0 , the axiomatic consistency of the model should be pointed out. In fact, the model is crucially dependent on the use of internal nonconservative and non-Hamiltonian forces, thus being nonunitary when formulated on a conventional Hilbert space over a conventional numerical field. The formulation of the model via hadronic mechanics is the only one known to the authors bypassing the *Theorems of Catastrophic Mathematical and Physical Inconsistencies of Nonunitary Theories* reviewed in Section 6.7, thus achieving axiomatic consistency, with particular reference to invariance over time of: numerical predictions, Hermiticity and observability that are necessary for any model to have physical value.

2) **Suppression of the atomic energy spectrum.** This feature is achieved by the property that, under values (6.62), *the Hulthen potential admits one and only one energy level, the π^0* because of the following maximal possible value

$$M = 1, \quad (6.64)$$

and the binding energy is very small,

$$E = -(4.27 \times 10^{-2})^2 \times (1 + 4.27 \times 10^{-2}/4 \times V \approx 0. \quad (6.65)$$

In turn, this implies the following value of the isorenormalized energy of the isoelectron

$$m' = \frac{m}{|\widehat{I}^2|} \approx 68 \text{ MeV}, \quad (6.66)$$

which value is crucial for the consistency of Eq. (6.50a). As stressed earlier, the suppression of the atomic energy spectrum is crucial for the consistency of the model because any energy spectrum would imply the transition from the structure to the classification problem. Additionally, any excited state of the π^0 would imply exiting the hadronic horizon, thus returning to a quantum structure. Needless to say, *the excited states of Santilli structure model of the π^0 meson are the positronium states.*

3) **Ignorable binding energies.** The very small value of the binding energy, $E' \approx 0$, should be clarified because generally believed as being inconsistent by readers with vast knowledge of quantum mechanics but insufficient technical knowledge of the covering hadronic mechanics. The forces primarily responsible for the above model are of *contact, zero-range type* for which the introduction of a potential, and, consequently, of a binding energy, has no physical meaning.

As indicated in the preceding section, Santilli eliminated the Coulomb interactions and absorbed them into the Hulthen term because the latter is much stronger (in absolute value) than the former at short distances. However, the Hulthen "potential" in Eq. (6.50a) is merely a *projection* of the nonpotential isounit as in Eq. (6.42). Hence, when properly formulated on a iso-Hilbert space over an isofield, *Santilli structure model of the π^0 shows no potential at all.* Hence, the value $E' \approx 0$, rather than being inconsistent, is necessary for the consistency of the model.

It is evident that, having opposite isocharges, the isoelectron and the isopositron attract each other according to the Coulomb law, thus having indeed a non-null negative binding energy. The point is that such an enlargement, that is, the solution of Eq. (6.35) rather than (6.50a), was not considered by Santilli in 1978B and its study has remained left to interested readers to this day. Note that the low value of the binding energy is in line with models of the so-called "asymptotic freedom."

4) **Strongly attractive hadronic couplings.** One of the most scientifically productive features of the above structure model has been the identification of strongly attractive contact forces between particles when in singlet couplings under conditions of overlapping of their wavepackets or their charge distributions. This force has been crucial for the conception and industrial development of new clean energies studied in the next chapter.

5) **Charge independence of strong interactions.** Another central point in Santilli's structure model of hadrons is that, unlike electromagnetic interactions, *strong interactions are primarily characterized by (nonlinear, nonlocal-integral and) nonpotential interactions* he represents with the isounit. Such a conception is necessary, in any case, for the consistency of the model here considered because, as well known, the π^0 meson is a strongly interacting particle.

But one of the main features of strong interaction is their charge independence. Consequently, A. O. E. Animalu pointed out in the memoir [167] that the contact interaction characterized by the Hulthen force is so strong to overcome Coulomb *repulsion* between identical electrons resulting in the birth of a broader formulation of superconductivity and related Cooper pair studied in Chapter 5. Subsequently, Santilli and Shillady realized that the same force is responsible for the strength of valence electron pairs, as presented in the paper [113], by achieving the first known exact representation of molecular binding energies from unadulterated first principles.

6.2.D Structure model of unstable leptons and of the remaining mesons

Next, Santilli provided in memoir 1978B a quantitative analytic solution of the following structure models of unstable leptons and of the remaining light (unflavored) mesons based on Assumptions 1–5 of Section 6.1C:

$$\mu^\pm(105 \text{ MeV}) = (\widehat{e}^+, \widehat{e}^\pm, \widehat{e}^-)_{\text{hm}}, \quad (6.67a)$$

$$\pi^\pm(139 \text{ MeV}) = (\widehat{\pi}^0, \widehat{e}^\pm)_{\text{hm}}, \quad (6.67b)$$

$$\eta(547 \text{ MeV}) = (\widehat{\pi}^0, \widehat{\pi}^0)_{\text{hm}}, \quad (6.67c)$$

$$K^\pm(494 \text{ MeV}) = (\widehat{\pi}^0, \widehat{\pi}^\pm)_{\text{hm}}, \quad (6.67d)$$

$$K_S^0(498 \text{ MeV}) = (\widehat{\pi}^0, \widehat{\pi}^0, \widehat{\pi}^0)_{\text{hm}}, \quad (6.67e)$$

$$K_L^0(498 \text{ MeV}) = (\widehat{\pi}^0, \widehat{\pi}^0, \widehat{\pi}^0)_{\text{hm}}. \quad (6.67f)$$

Let us consider first the three-body hadronic bound state models (6.67a) and (6.67b). The first difficulty in the acceptance of these models is the need to abandon quantum mechanics in favor of covering hadronic mechanics due to the impossibility of the former to represent the rest energies of the particles considered, as it was the case for the π^0 .

Additionally, we see the emergence of the following new difficulty. Model (6.67a) readily represents the spin of the muons, while there is no possibility for quantum mechanics to represent the spin 0 of the π^\pm mesons as bound states of three particles each having spin 1/2 when in vacuum. Consequently, models (6.67) were generally dismissed by the physics community of the late 1970s because impossible under Lie's theory. This caused a significant scientific impasse in hadron physics, including decades of delays in the conception and industrial

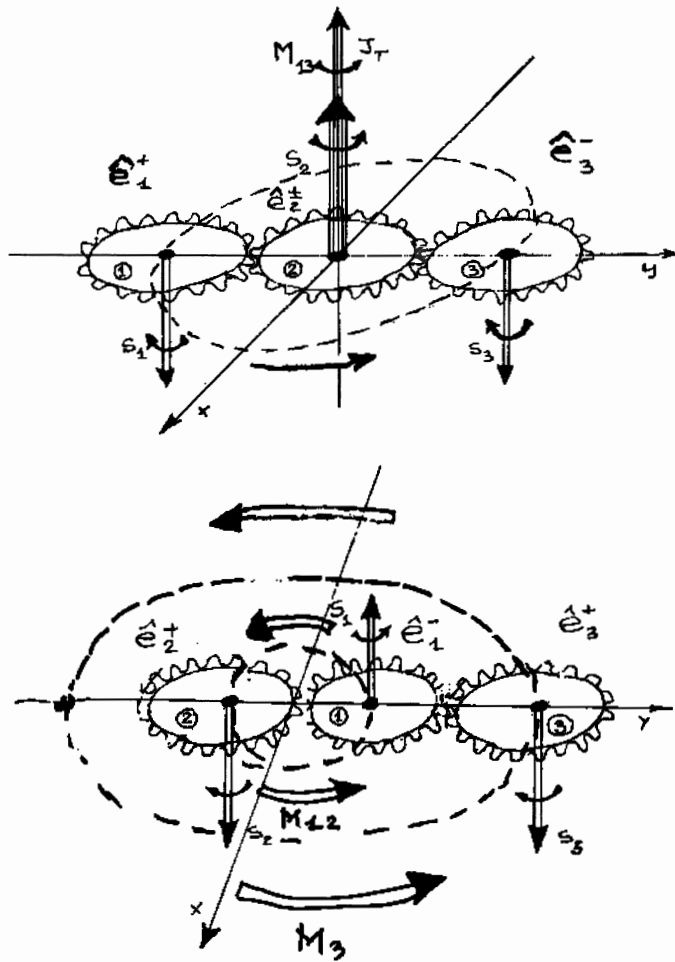

Figure 6.6. Reproduction of the original figure used by Santilli in Section 5 of the memoir 1978B to illustrate the dynamical differences between his structure model of the μ^\pm (top view) and of the π^\pm (bottom view). In the former case, we have an isoelectron e^\pm at the center and two isoelectrons orbiting around, thus requiring no mutation of the angular momentum to represent the spin 1/2 of the muons. In the latter case, we have a π^0 at rest in the center (since it is much heavier than the electron) with an isoelectron e^\pm orbiting within the π^0 structure (since the size does not increase appreciably in the transition from the π^0 to the π^\pm). In the latter case, a mutation of the total angular momentum of the isoelectron is necessary to represent the spin 0 of the π^\pm mesons. These two different values of the spin under the same number of elementary constituents are an excellent verification of the regular and irregular isorepresentations of the Lie-Santilli $SU(2)$ spin symmetry outlined in the next section for the structure of the neutron. As we shall see, the two cases here considered are interpreted by Santilli as providing a direct distinction between electroweak and strong interactions (see HMMC Vol. III for details and references).

development of much needed new clean energies (studied in the next chapter), since the latter are crucially dependent on *deviations* from quantum mechanics within hadronic media.

In our view, the above impasse was justified in 1978 since, at that time, Santilli had just proposed the isotopies of Lie's theory in the preceding memoir 1978A. Moreover, said isotopies were presented as particular cases of the broader Lie-admissible genotopies of Lie's theory for irreversible conditions, thus dealing with a mathematical level beyond that of the general physics audience of the time.

Despite the lack of general acceptance of his structure model of hadrons, Santilli spent decades of solitary studies to develop in all details the theory nowadays known as the *Lie-Santilli isothory*, with particular reference to the isotopies of the $SU(2)$ -spin symmetry and its isorepresentations (reviewed in Chapters 2 and 3), by showing in the 1990s that model (6.67b) can indeed represent the spin 0 of the π^\pm mesons in a fully consistent way, provided one accepts the existence within hyperdense hadrons of nonlinear, nonlocal and non-Hamiltonian interactions beyond any dream of representation via Lie's theory.

As a matter of fact, Santilli noted in memoir 1978B that the problem of the spin of the π^\pm is essentially equivalent to that of the spin of the neutron when interpreted as a bound state of a proton and an electron because, in both cases, there is the need of the *mutation of spin* in addition to that of the rest energy. To follow the historical evolution, we shall review the mutation of spin in the next section, as originally achieved for the structure of the neutron. In this section, we shall limit ourselves to a review of the original presentation in memoir 1978B.

In regard to model (6.67a), Santilli states: *With all due respect to different views by my colleagues, I could never accept the hypothesis that muons are elementary because they are naturally unstable with spontaneous decays releasing electrons and positrons. Hence, the most natural hypothesis is to assume that the muons are bound states of electrons and positrons. The decay mode*

$$\mu^\pm \Rightarrow e^+, e^\pm, e^- \quad (6.68)$$

suggested that muons are three-body bound state of an electron-positron pair plus an electron, since such a structure allows the representation of muons rest energy, spin, meanlife, magnetic and electric dipole moments and decays via electron-positron annihilation or other processes. As well known, such a conception is utterly inconsistent for quantum mechanics due to the inability of Schrödinger's equation to represent the muon rest energy. Rather than restraining my studies, such an inconsistency provided additional reasons to build a new mechanics specifically conceived for the structure of unstable particles, so as to prevent the adaptation of physical reality to a preferred theory.

The main characteristics of the μ^\pm are the following:

$$\text{Rest energy: } E_{\mu^\pm} = 105.66 \text{ MeV,} \quad (6.69)$$

$$\text{Meanlife: } \tau_{\mu^\pm} = 2.19 \times 10^{-6} \text{ sec,} \quad (6.70)$$

$$\text{Spin: } S_{\mu^\pm} = 1/2, \quad (6.71)$$

$$\text{Charge: } C_{\mu^\pm} = \pm e, \quad (6.72)$$

$$\text{Magnetic moment: } \mu_{\mu^\pm} = 1.0011\mu_e, \quad (6.73)$$

$$\text{Electric dipole moment: } \varepsilon_{\mu^\pm} = 3.27 \times 10^{-19} \text{ e.cm,} \quad (6.74)$$

$$\text{Charge radius: } R_{\mu^\pm} = 10^{-19} \text{ cm.} \quad (6.75)$$

In Section 5 of memoir 1978B, Santilli provided an exact analytic solution of model (6.67a) via its reduction to a *restricted three body system* that reproduced the analytic treatment of the preceding sections, resulting in the following numerical values of the characteristic k -quantities:

$$k_1 = 2.62 \times 10^{-7}, \quad (6.76a)$$

$$k_2 = 1 + 4.96 \times 10^{-5}, \quad (6.76b)$$

that should be compared with the corresponding values (6.62).

Note that k_2 is bigger than, but very close to 1. Hence, structure model (6.67a) also suppresses the atomic spectrum, this time, of the helium, down to one single energy level, that of the muon. It was noted in memoir 1978B that the above values were computed for the charge radius of the muon $R = 10^{-19}$ cm and that, $R \Rightarrow 0$ implies $k_2 \Rightarrow 1$.

The rest energy of the muon, as well as other features, such as the differences in magnetic and electric dipole moments between muons and electrons were interpreted via a mutation of the central isoelectrons \widehat{e}^\pm , thus confirming the need for hadronic mechanics. The argument is that deformations of the shape of charged spinning bodies are known in classical mechanics to cause corresponding deformations of magnetic moments. Santilli then argued that the central electron in structure (6.67a) must experience a deformation of its wavepacket due to its immersion within those of the other electrons, with consequential, inevitable alteration (mutation) of the intrinsic magnetic moment.

Decay (6.68) is interpreted as hadronic tunnel effect of the constituents along the same lines as for the π^0 . The other decays are interpreted via the annihilation of the isoelectron-isopositron pair, leaving the residual electron or positron isolated in vacuum, thus re-acquiring its quantum features.

In regard to model (6.67b), Santilli states: *Again with due respect to different view by my colleagues, I could not accept that the π^\pm mesons have the same number of constituents of the π^0 , because the latter admits the spontaneous decay*

into an electron-positron pair, while the former admits the dominant decay

$$\pi^\pm \Rightarrow \mu^\pm + \nu, 99.98\%, \quad (6.77)$$

thus suggesting that the π^\pm are mutated forms of μ^\pm . But the structure model of μ^\pm requires a three-body structure. This occurrence left no other alternative than the increase of the number of constituents by one in the transition from π^0 to π^\pm . Similar inspections of spontaneous decays of other unstable hadrons and leptons then lead to the rule according to which the number of elementary massive physical constituents of unstable particles increases with mass.

The main characteristics of the π^\pm as the following:

$$\text{Rest energy: } E_{\pi^\pm} = 139.57 \text{ MeV}, \quad (6.78)$$

$$\text{Meanlife: } \tau_{\pi^\pm} = 2.6 \times 10^{-8} \text{ sec}, \quad (6.79)$$

$$\text{Charge radius: } R_{\pi^\pm} = 10^{-13} \text{ cm}, \quad (6.80)$$

$$\text{Spin: } S_{\pi^\pm} = 0, \quad (6.81)$$

$$\text{Charge: } C_{\pi^\pm} = \pm e. \quad (6.82)$$

By reducing the three-body structure to the two-body form (Eq. 6.67b), and the use of the treatment of the preceding sections, memoir 1978B provided another exact analytic solution resulting again in the invariant representation of all the characteristics of the π^\pm with the sole exception of the spin that was deferred to studies following the development the isotopies of Lie's theory. In particular, memoir 1978B found the following numerical values of the characteristic k -quantities

$$k_1 = 3.49 \times 10^{-3}, \quad (6.83a)$$

$$k_2 = 1 + 6.51 \times 10^{-7}, \quad (6.83b)$$

that should be compared with values (6.62) and (6.76).

Primary decay (6.77) is considered the strongest evidence in support of the models for both pions and muons. In fact, strong spin-orbits couplings as needed for the spin of structure (6.67b) are unstable, thus implying the dominance of decay process (6.77) where there is no such strong spin-orbit coupling. The hadronic interpretation of the remaining decays is also possible, and left to interested readers.

In regard to structure models (6.67c)–(6.67e), Santilli states: *In the structure models of the remaining light mesons I encountered the following new scenario. The preservation of the charge radius with the increase of the mass prevented the introduction of hadronic excited states, thus forcing the total immersion of new constituents into preceding structures. On one side, this provided a great exemplification of the calculations, since all light mesons could be reduced to two-body structures essentially similar to that of the π^0 . However, the increase of the*

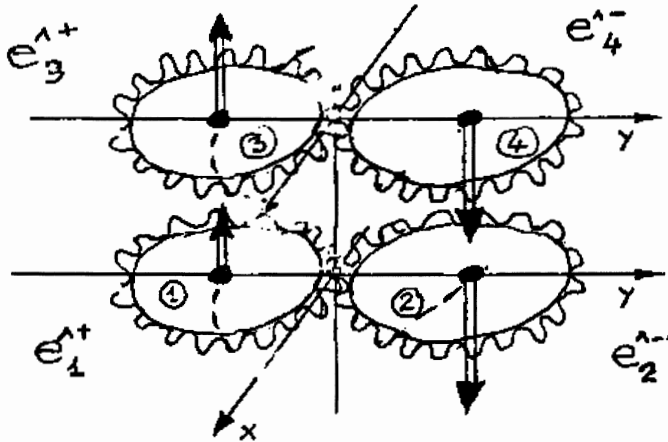

Figure 6.7. Reproduction of the original figure of memoir 1978B to illustrate the structure model of the η meson with four elementary massive constituents. Note the “compression” of two $\hat{\pi}^0$ one inside the other.

density caused a multiplication of internal process requiring hadronic field theory that is not yet available, resulting in a number of alternatives in need of specific studies.

As an example, following the two elementary massive constituents for the π^0 and three constituents for the π^\pm , it was natural for me to assume in 1978 that the η meson is a bound state of two mutated π^0 . However, the η admits the decay

$$\eta \Rightarrow 3\pi^0 \quad (32\%), \tag{6.84}$$

$$\eta \Rightarrow \pi^\pm + \pi^\pm + \pi^\pm \quad (28.5\%) \tag{6.85}$$

and other decays suggesting a higher number of elementary constituents. The new aspect is that the above decays are no longer final indication of the number of elementary constituents because, with the increase of the density of the medium inside hadrons, there is the emergence of a host of basically new events, such as the creation of electron-positron pairs that, within the environment considered, are the π^0 , resulting in the following equivalence

$$\eta = (\hat{\pi}^0, \hat{\pi}^0)_{\text{hm}} \approx (\hat{\pi}'^0, \hat{\pi}'^0, \hat{\pi}'^0)_{\text{hm}} \approx (\hat{\pi}'^\pm, \hat{\pi}'^\pm, \hat{\pi}'^\pm)_{\text{hm}}. \tag{6.86}$$

A similar situation holds for the K^\pm that I considered in 1978 as being a five-body bound state of elementary massive constituents, or a two-body bound state of two mutated pions, or a two-body bound state of a mutated η meson and an isoelectron:

$$K^\pm = (\hat{\pi}^0, \hat{\pi}^\pm)_{\text{hm}} \approx (\hat{\eta}, \hat{e}^\pm)_{\text{hm}}. \tag{6.87}$$

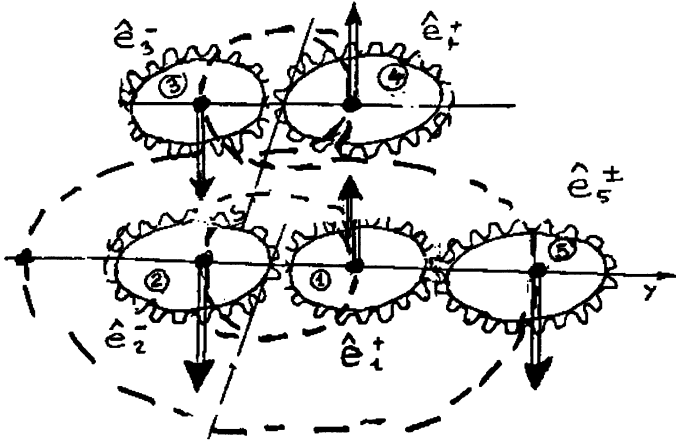

Figure 6.8. Reproduction of the original figure of memoir 1978B illustrating the structure model of the K^\pm with five constituents.

Again there is no contradiction with decays of the type

$$K^\pm \Rightarrow \mu^\pm + \nu \quad (63\%), \quad (6.88)$$

$$K^\pm \Rightarrow \pi^\pm + \pi^0 \quad (21\%) \quad (6.89)$$

due to the creation of pions and other particles within the structure.

Finally, by following the same lines, it was also natural for me in 1978 to assume that the K_S^0 and the K_L^0 have six elementary massive constituents, thus being composed of three mutated π^0 . Their differences was then reduced to dynamical differences similar to those existing for μ^\pm and π^\pm , namely, we have the first possibility with one $\hat{\pi}^0$ at the center and two $\hat{\pi}^0$ orbiting in its interior, and the second possibility with two $\hat{\pi}^0$ coalesced into the $\hat{\eta}$ and the remaining $\hat{\pi}^0$ orbiting in its interior.

All in all, I believe that the complexity of the events within the hyperdense hadronic medium is beyond our imagination at this writing, let alone our capacity of their analytic treatment. This aspect is best illustrated by the mystery of the origin of the 0.872 MeV missing in the synthesis of the neutron in the core of stars. Rather than being a drawback, these difficulties should intrigue true researchers with young mind of any age.

With the above clarifications, we shall assume models (6.67) as representative of the capabilities of Santilli's structure model of hadrons with elementary, physical, massive constituents, by leaving open their detailed study for interested colleagues. What is important for this presentation is that *Santilli reduction of unstable leptons and light mesons to electrons and positrons is indeed plausible and does indeed provide an exact representation of all characteristics of the con-*

sidered particles and their decays much beyond any possible representation with quark conjectures.

6.2.E Revisions due to the isodual theory of antimatter

In the preceding sections we have reviewed Santilli's structure model of unstable leptons and mesons as conceived in 1978. It is important to indicate that the sole significant advance since that time known to the authors has been the subsequent advent of the *isodual theory of antimatter* also due to Santilli, as reviewed in Section 3.7, see the comprehensive treatment in the 2006 monograph [19], which is based on the operation of *isoduality* consisting of an anti-Hermiticity map applied to the totality of the formalism of matter, from numbers to first quantization.

As the reader may recall, the new theory was motivated by the historical imbalance of the 20th century between matter and antimatter, matter being treated at all levels of study from Newton to second quantization, while antimatter was solely treated at the level of second quantization. Santilli's isoduality has resolved this historical imbalance, by allowing the treatment of both, matter and antimatter, at all levels of study, from Newton to second quantization, in full scientific democracy.

The implications of this new formulation of antimatter are important for the hadronic structure model of particles and can be indicated as follows. By denoting the electron with the symbol e , the isoelectron with the symbol \hat{e} and their isoduals (antiparticles) with the symbols e^d and \hat{e}^d , model (6.2) should be written more correctly

$$\pi^0 = (\hat{e}_\downarrow, \hat{e}_\uparrow^d)_{\text{hm}}, \quad (6.90)$$

and the same rules applies for all antiparticles. Far from being trivial, the reader should be aware that the isodual theory avoids the second quantization, thus allowing the treatment of anti-isoparticles at the level of first hadronization under a total democracy between particles and antiparticles.

Additionally, Santilli has discovered a new important symmetry verified by Dirac's equation as well as by the entire universe at the limit of equal matter and antimatter. It is given by the *isoselfduality*, namely, by the invariance under isoduality. The π^0 particle is isoselfdual because it is composed by a particle and its antiparticle. However, *its decay into two γ , Eq (6.3), is inconsistent because it violates isoselfduality*, thus confirming the insufficiency of 20th century particle physics in regard to antiparticles. In fact, the correct formulation of the π^0 decay is the following one verifying isoselfdual invariance on both sides

$$\pi^0 \Rightarrow \gamma + \gamma^d, \quad (6.91)$$

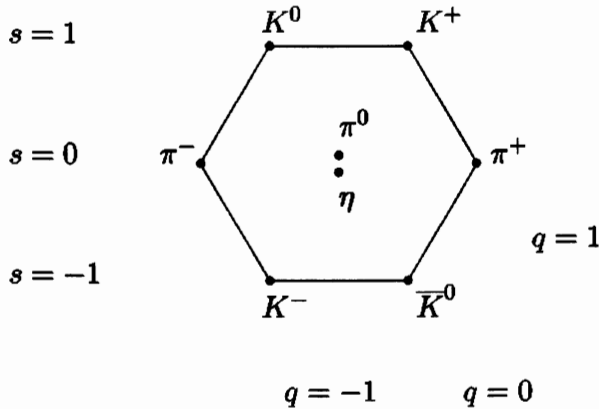

Figure 6.9. A view of the historical octet of light (unflavored) mesons from Wikipedia.

that, alone, is sufficient to illustrate the experimentally detectable inequivalence of photons produced by matter and antimatter, a feature that has stimulated the birth of the new field of *antimatter astrophysics*.

It is an instructive exercise for the interested reader to reformulate the preceding structure models of leptons and hadrons in the remaining aspects involving antiparticles and identify the nontrivial consequences.

6.2.F Compatibility of the new structure model of hadrons with unitary classifications

The compatibility of the structure model of mesons with physical, massive, and elementary constituents and the $SU(3)$ classifications was worked out in Section 3.15 of the 1997 memoir [99]. Said compatibility is conceptually simple, but mathematically quite advanced since it requires the multi-valued hyperstructural lifting of the Lie-Santilli isothory indicated in Chapter 2.

Let us recall the basic *meson octet* as characterized by the $SU(3)$ symmetry (see Figure 6.9) which, by indicating anti-quarks with a dash, can be written

$$\begin{aligned}
 \text{Meson octet} = \{ & \pi^0(135) = (dd' - uu'), \pi^+(140) = (ud'), \\
 & \pi^-(140) = (ud'), \eta(549) = (dd' + uu'), K^+(494) = (us'), \quad (6.92) \\
 & K^0(498) = (ds'), \bar{K}^0(494) = (u's), K^-(498) = (d's) \}.
 \end{aligned}$$

A basic implication of hadronic mechanics is that different hadrons are characterized by different isounits. Consequently, in the 1997 memoir, Santilli proposes

the identification of the octet of light mesons via the *total isounit*

$$\hat{I}_{\text{Tot, Oct}} = \left(\hat{I}_{\pi^0(135)}, \hat{I}_{\pi^+(140)}, \hat{I}_{\pi^+d(140)}^d, \hat{I}_{\eta(549)}, \right. \\ \left. \hat{I}_{K^+(494)}, \hat{I}_{K^0(498)}, \hat{I}_{K^+d(494)}^d, \hat{I}_{K^0d(958)}^d \right). \quad (6.93)$$

The proposed compatibility between the hadronic structure model and the $SU(3)$ classification is then achieved via *the isotopic lifting of the $SU(3)$ symmetry with respect to the above total isounit* since the latter is known to be isomorphic to $SU(3)$, thus preserving all features of the latter, including the numerical predictions. For the study of the hyperstructural branch of hadronic mechanics we refer the interested reader to the 1995 monographs [12, 14, 95].

The significant of the above hyperformulations of the $SU(3)$ symmetry is that of *identifying quarks as they really are, purely mathematical objects defined on purely mathematical internal spaces without connection to our spacetime*. In fact the u, d, s quarks characterized by hyperunit (6.93) are regular hyperrepresentation of $SU(3)$ that remain three-dimensional, although but 8-valued, thus without any possibility of definition in our spacetime.

6.2.G Experimental verifications

In Santilli's view, the most significant direct experimental verification of the hadronic structure model of unstable leptons and mesons is that it represents all intrinsic characteristics of the particles and their spontaneous decay, thus achieving a representation of experimental data not possible for quark conjectures, such as the representation of meanlives, charge radius, and other features.

The most significant indirect experimental verifications are the following. The hadronic structure model considered in this section is centrally based on the inapplicability of special relativity and quantum mechanics in the interior of hadrons, inapplicability that is nowadays supported by rather vast experimental evidence reviewed in Chapter 5.

It is sufficient to indicate in this respect the recent experimental evidence of deviation from the Doppler's law within physical media [130] that, alone, establishes the inapplicability of special relativity within physical media at large, thus including the hyperdense media inside hadrons, in favor of Santilli isorelativity. This occurrence, alone, establishes the inapplicability in the interior of hadrons of relativistic quantum mechanics in favor of the covering relativistic hadronic mechanics. The structure model of unstable particles studied in this section then follows uniquely and unambiguously due to the direct universality of the covering theory.

Independently from all the above, the reader should remember that the studies presented in this section are based on the isotopic branch of hadronic mechanics, thus being limited to processes that are *reversible over time* (invariant under time

reversal). Note that such a restriction is fully permitted by the basic assumption that the constituents of hadrons are massive particles produced free in the spontaneous decays.

However, the most significant decays are *irreversible over time*, thus preventing the use of quantum mechanics due to its reversible structure, and mandating the use of the irreversible Lie-admissible branch of hadronic mechanics.

In summary, we can conclude by saying that the hadronic structure model of unstable leptons and light mesons presented in this sections is supported by a rather significant number of conceptual, mathematical, theoretical, and experimental evidence.

6.3 Reduction of Baryons to Protons and Electrons

6.3.A Conception of the neutron structure

As recalled earlier, Santilli accepted Rutherford's original conception of the neutron as a "compressed hydrogen atom" in the core of stars, identified the reasons for the impossibility by quantum mechanics to represent such a natural conception, and proposed the construction of the covering hadronic mechanics for its quantitative study.

Following a lifelong preparatory research outlined in this volume, Santilli was finally able to achieve the first known *nonrelativistic, numerically exact, and invariant representation of "all" characteristic of the neutron as a hadronic bound state of a proton and an electron* in the historical paper [62] (hereon referred to as the "1990 paper") as well as in the ICTP paper [66] (referred to as the "1992 paper").

Subsequently, while visiting the *Joint Institute for Nuclear Research* in Dubna, Russia, Santilli achieved the first known *relativistic, numerically exact, and invariant representation of "all" characteristics of the neutron in its synthesis from a proton and an electron inside stars* in the paper [82] (referred to the "1993 paper") subsequently published in China while visiting the *Academia Sinica* in Beijing, in the paper [90] (referred to as the "1995 paper").

The most comprehensive studies were provided in the monographs [20–24] (referred to as HMMC). Among various independent studies, an excellent review is that by J. Kadeisvili in the memoir [197].

Santilli main concretion of the neutron structure is expressed via nonrelativistic and relativistic *nonunitary* liftings of the conventional treatment of the hydrogen atom (hereon denoted "ha") with quantum mechanics (qm) into the corresponding forms of hadronic mechanics (hm),

$$\text{ha} = (p^+, e^-)_{qm} \Rightarrow n = (\widehat{p}^+, \widehat{e}^-)_{hm} = U[(p^+, e^-)_{qm}]U^\dagger, \quad (6.94)$$

$$UU^\dagger \neq I, \quad (6.95)$$

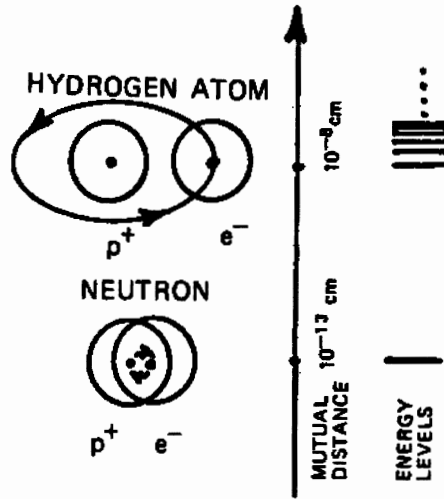

Figure 6.10. The sole bound state of a proton and an electron predicted by quantum mechanics is the hydrogen atom, with smallest orbit of the order of 10^{-8} cm. Thanks to the use of hadronic mechanics, Santilli has identified the existence of one and only one additional bound state, the neutron, characterized by the electron orbiting within the proton structure at distances of the order of 10^{-13} cm or less. Remarkably, Santilli has proved that the hadronic state is one and one only because, when excited, the isoelectron leaves the proton structure, thus recovering all conventional quantum states. In this sense, the energy levels of the hydrogen atom are the excited states of the neutron. As we shall see, these notions are at the foundation of the new hadronic energy studied in Chapter 7.

where hat denotes the lifting of protons and electrons into *isoprotons* and *isoelectrons*, respectively, more technically realized via the transition of unitary irreducible representations from the Galilei symmetry to the Galilei-Santilli isosymmetry at the nonrelativistic level and from the Lorentz-Poincaré symmetry to the covering Lorentz-Poincaré-Santilli isosymmetry at the relativistic level.

In this section we provide a review of the nonrelativistic and relativistic treatments in a form accessible to the general physics audience. However, it should be indicated again that a serious understanding of these achievements requires a technical knowledge of the entire studies because all deeply interconnected in a direct or indirect way to the neutron structure.

6.3.B Nonrelativistic exact and invariant representation of the neutron rest energy, meanlife and charge radius

The original 1990 derivation of the exact and invariant nonrelativistic representation of the rest energy, mean life and charge radius of the neutron follows very close that of the π^0 presented in the preceding section and, therefore, we shall

review it only in its main aspects. The basic model is the familiar Schrödinger's equation for the structure of the *hydrogen atom*

$$H|e\rangle = \left(-\frac{\hbar^2}{2m}\Delta - \frac{e^2}{r} \right) |e\rangle = E|e\rangle, \quad (6.96)$$

$$p|e\rangle = -i\hbar\partial_r|e\rangle, \quad (6.97)$$

$$m = \frac{m_e \times m_p}{m_e + m_p} \approx m_e, \quad (6.98)$$

where $|e\rangle = |e(t, r)\rangle$ represents the conventional Hilbert state of the hydrogen atom. Since the proton mass is about 2000 times bigger than the electron mass, Santilli assumes in first nonrelativistic approximation that the proton is at rest in the neutron structure and it is not mutated, thus studying the particular case

$$n = (p_{\downarrow}^+, \widehat{e}_{\uparrow}^-)_{\text{hm}}. \quad (6.99)$$

The next step is to subject Eqs. (6.96), (6.97) to a nonunitary transforms by reaching again the main equations of hadronic mechanics,

$$UH|e\rangle U^\dagger = (UHU^\dagger)(UU^\dagger)^{-1}(U|e\rangle U^\dagger) = \widehat{H}\widehat{T}|\widehat{e}\rangle = \left(-\frac{1}{m'}\Delta + V_{\text{Coulomb}} \right) |\widehat{e}\rangle = E'|\widehat{e}\rangle, \quad (6.100)$$

$$m' = \frac{m}{|\widehat{I}^2|}, \quad (6.101)$$

where m' is the isorenormalized rest energy of the electron as in Eq. (6.38) and E' is the isorenormalized binding energy due to the transition from the Hamiltonian H to the new operator $\widehat{H}\widehat{T}$. At this point, the 1990 paper introduces the trigger since the hydrogen atom cannot spontaneously change into the neutron unless there is a sufficient external action. In this case, the extreme pressures in the center of a star are represented again with the Hulthen potential, resulting in the modified hadronic equation

$$\left(-\frac{1}{m'}\Delta + V_{\text{Coulomb}} + V_{\text{Hulthen}} \right) |\widehat{e}\rangle = \left(-\frac{1}{m'}\Delta - \frac{e^2}{r} - K \frac{\exp(-r/R)}{1 - \exp(-r/R)} \right) |\widehat{e}\rangle = E'|\widehat{e}\rangle. \quad (6.102)$$

The Coulomb potential is again absorbed into the much stronger Hulthen potential inside the hadronic horizon, and the coupling of the proton and the electron is necessarily assumed as being in singlet, resulting in this way in the *nonrelativistic*

structure equation of the neutron for the rest energy, mean life and charge radius similar to those for the π^0 , Eq. (6.50),

$$n = (\widehat{e}_\uparrow^-, p_\downarrow^+)_{\text{hm}}, \tag{6.103a}$$

$$\left[\frac{1}{r^2} \frac{d}{dr} r^2 \frac{d}{dr} + \frac{4\pi^2 m'}{h^2} \left(E' + N \frac{\exp(-r/R)}{1 - \exp(-r/R)} \right) \right] |\widehat{e}\rangle = 0, \tag{6.103b}$$

$$E_n = E_p + E_{\widehat{e}} - |E'| = 939 \text{ MeV}, \tag{6.103c}$$

$$2\lambda^2 |\widehat{e}(0)|^2 \alpha E_{\widehat{e}} / h = 10^3 \text{ sec}, \tag{6.103d}$$

$$R = 10^{-13} \text{ cm}, \tag{6.103e}$$

The 1990 paper then studies in detail the analytic solution, by recovering the finite spectrum of the Hulthen potential,

$$E = - \left(\frac{\widehat{m}R^2V}{h^2n} - n \right)^2 \frac{h^2}{4\widehat{m}R^2}, \tag{6.104}$$

$$n = 1, 2, \dots, M = \text{maximal integer in } \frac{\widehat{m}R^2V}{h^2n}. \tag{6.105}$$

Differential equation (6.103) were then turned into the algebraic equations

$$E_{\widehat{e}} = \frac{k_1 hc}{R} = \frac{h^2}{2m'R^2}, \tag{6.106}$$

$$\frac{m'VR^2}{h^2} = k_2 = 1 + \varepsilon, \quad 0 \leq \varepsilon < 1, \tag{6.107}$$

where the expression $0 \leq \varepsilon < 1$ originates from the boundary conditions. In this case the Hulthen constant becomes

$$V = \frac{k_2 h^2}{m'R^2} = 2k_2 E_{\widehat{e}} = 2E_{\widehat{e}}, \tag{6.108}$$

because k_2 is very close to 1. As we shall soon see, the above expression establishes that the value of V is rather large. In turn, this establishes the strength of the strong nonpotential interactions.

In this way, by plotting the numerical values, Santilli reduces Eqs. (6.103) to the solution of the following algebraic equations in the k -parameters

$$k_1 [1 - (k_2 - 1)^2] = \frac{ER}{2c}, \tag{6.109}$$

$$\frac{(k_2 - 1)^3}{k_1} = 9 \times 10^6 \frac{R}{4\pi c\tau}, \tag{6.110}$$

with numerical value for the neutron

$$k_1 = 2.6, \quad (6.111a)$$

$$k_2 = 1 + 0.081 \times 10^{-8}, \quad (6.111b)$$

that should be compared to the corresponding values (6.62) for the π^0 .

Again, as it is the case for the π^0 , numerical values imply the *suppression of the quantum spectrum of energy of the hydrogen atom down to one energy level only, that of the neutron*. Again model (6.103) admits excited states, but they cross the hadronic horizon, thus being fully quantum. Consequently, in Santilli's view, all known quantized level of the hydrogen atom are excited states of the neutron.

A result achieved by the 1990 of primary importance for new clean energies (see Chapter 7) is that *the binding energy E' is very small, as expected from the "nonpotential" character of the primary binding force*, as a result of which the total energy of the isoelectron is given by

$$E_{\hat{e}} \approx E_n - E_p = 1.293 \text{ MeV}. \quad (6.112)$$

As we shall see, the reduction of the neutron to a hadronic bound state of a proton and an electron has far reaching implications for all quantitative sciences, e.g., because nuclei can now be reduced to isoprotons and isoelectrons as shown in Section 6.5. The reduction also has far reaching industrial implications, e.g., because the isoelectron can be stimulated to exit the neutron, thus permitting the utilization of the inextinguishable clean energy inside the neutron as outlined later on in this section.

In closing this section, we should indicate that the above model has been reinspected since 1990 various times. A reinspection worth mentioning is that by Animalu and Santilli of 1996 [92], who re-derived Eqs (6.103) via the use of the following realization of the isounit

$$\hat{I} = \exp \left(-r \times \frac{\exp(-r/R)}{1 - \exp(-r/R)} \times \int \hat{e}_{\uparrow}^- \times p_{\downarrow}^+ d^3r \right), \quad (6.113)$$

that can be written

$$\hat{I} = \exp \left(-\frac{|e\rangle}{|\hat{e}\rangle} \times \int \hat{e}_{\uparrow}^- \times p_{\downarrow}^+ d^3r \right), \quad (6.114)$$

where $|e\rangle$ is the wavefunction of the ordinary electron and $|\hat{e}\rangle$ is that of the isoelectron. This re-interpretation illustrates again the desired character of hadronic mechanics as being nonlinear in the wavefunctions, yet reconstructing linearity on isospaces over isofield (isolinearity). The nonpotential character of the interactions represented with the isounit is self-evident and needs no additional comments.

For clarity, we should indicate that isounit (6.113) is different than our form (6.44) because the charge was mutated in the later realization, while it was left unchanged in the former.

6.3.C *Nonrelativistic, exact and invariant representation of the neutron spin*

The 1990 paper then considers the initiation of Rutherford's compression of the electron within the proton in singlet coupling, as illustrated in Figure 6.11. It is evident that, *as soon as the penetration begins, the electron is trapped inside the hyperdense, much heavier and spinning proton, thus resulting in a constrained orbital motion.* This is due to the fact indicated earlier that the proton is about 2000 times heavier than the electron, as a result of which the proton can be assumed in first approximation as remaining at rest and un-mutated in its intrinsic angular momentum, while contributions from the proton mutations can at best be of second order or of relativistic character. In this way, Santilli reached the conclusion in the 1990 paper that, under the geometry of Rutherford's compression, *the electron is constrained to have an orbital angular momentum equal to the proton spin, namely an angular momentum with the value 1/2, yet opposite to the electron spin. Therefore, the spin of the neutron coincides with that of the proton.*

It should be stressed that *the above interpretation of the neutron spin is prohibited by quantum mechanics because angular momenta can only have integer eigenvalues.* This is due to the fact that half-odd-integer angular momenta imply the breakdown of the unitarity of the theory, with a consequential host of problems, including the loss of causality and probability laws (see the Theorems of Catastrophic Inconsistencies of Nonunitary Theories of Section 3.9). However, integer angular momenta were solely established for *particles moving in empty space.* Their supine acceptance as being also valid for a particle orbiting within a hyperdense medium without a serious scrutiny is deprived of scientific value. Also, constrained systems are well known in classical and quantum mechanics to imply anomalous eigenvalues. Finally, hadronic mechanics was constructed precisely for the regaining of unitarity on isospaces over isofields (Chapter 2). Therefore, *half-off-integer angular momenta are quite natural for the covering hadronic mechanics because permitted by the Lie-Santilli isotheory,* as shown below. The exact and invariant representation of the spin 1/2 of the neutron was first achieved in the 1990 paper, which also provides the resolution of related consistency problems. This first derivation can be summarized as follows.

Let $|s\rangle$ be the conventional two-dimensional basis of the $SU(2)$ spin symmetry with generators J_k , $k = 1, 2, 3$, conventional commutator rules and eigenvalues. Santilli applies in the 1990 paper the isotopic lifting of the $SU(2)$ symmetry worked out previously (characterized by the following isounit, isotopic element,

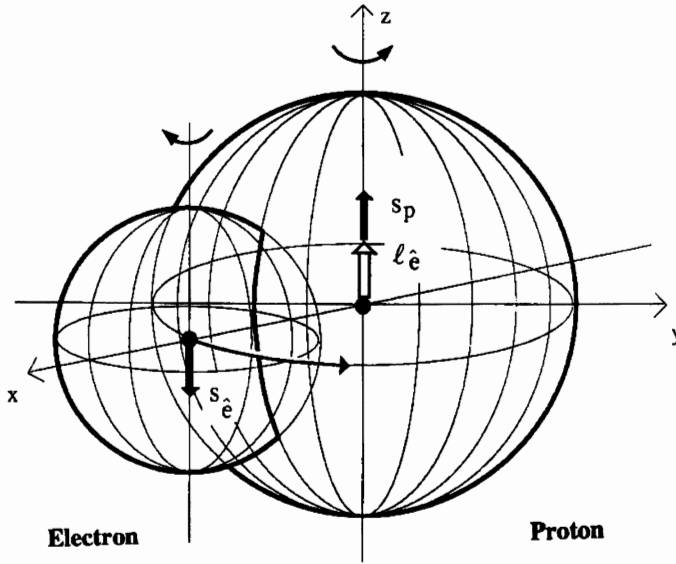

Figure 6.11. A reproduction of Figure 1 of Santilli 1990 on the spin of the neutron as permitted by hadronic mechanics. The main feature is the abandonment of the abstraction of the proton either as a point, or as a sphere with isolated points in its interior, as necessary for the applicability of quantum mechanics, and the representation of the proton as it is in the physical reality, a sphere of about 1 F in radius containing one of the densest media measured in laboratory until now. Then, at the initiation of “Rutherford’s compression” of the electron inside such hyperdense medium, it is evident that the electron is captured and constrained to rotate around the proton with an angular velocity equal to the proton spin. But the electron and proton can only couple in singlet for stability. It then follows that the total angular momentum of the isoelectron is null and the spin of the neutron coincides with the spin of the proton.

isocommutation rules and isoeigenvalues)

$$\widehat{I} = \text{Diag.}(g_1^{-1}, g_2^{-1}), \quad T = \text{Diag.}(g_1, g_2), \tag{6.115}$$

$$[\widehat{J}_i, \widehat{J}_j] = \widehat{J}_i T \widehat{J}_j - \widehat{J}_j T \widehat{J}_i = i\varepsilon_{ijk} \widehat{J}_k, \tag{6.116}$$

$$\widehat{J}^2 T |\widehat{s}\rangle = M(M + 1) |\widehat{s}\rangle, \tag{6.117}$$

$$\widehat{J}_3 T |\widehat{s}\rangle = N |\widehat{s}\rangle, \tag{6.118}$$

$$g_1 = g_2 = g, \tag{6.119}$$

where M and N will be identified shortly, and condition (6.119) is needed to assure isounimodularity. A realization of the above $\widehat{SU}(2)$ Lie-Santilli isoalgebra

is given by

$$\hat{J}_1 = \text{Offdiagonal}(g^{-1/2}, g^{-1/2}), \tag{6.120}$$

$$\hat{J}_2 = \text{Offdiagonal}(-ig^{-1/2}, i \times g^{-1/2}), \tag{6.121}$$

$$\hat{J}_3 = g/2 \times \text{Diag.}(g^{-1/2}, -g^{-1/2}), \tag{6.122}$$

with isoeigenvalues

$$\hat{J}^2 T|\hat{s}\rangle = \sum_k \hat{J}_k T \hat{J}_k T|\hat{s}\rangle = (PS)(PS + 1)|\hat{s}\rangle, \tag{6.123a}$$

$$\hat{J}_3 T|\hat{s}\rangle = \pm(PS)|\hat{s}\rangle, \tag{6.123b}$$

$$S = 1/2, P = \text{Det}(\hat{I}) = g^2, \tag{6.123c}$$

with corresponding liftings for three- and higher-dimensional cases (that require isounits of corresponding dimensions) here omitted for brevity.

It is evident that the above isotopic $\widehat{SU}(2)$ -spin symmetry characterizes the following *mutations of spin S and angular momenta L for an electron within the hyperdense medium inside the proton,*

$$S = 1/2 \Rightarrow \hat{S} = PS = P/2, P = g^2; \tag{6.124a}$$

$$L = 1 \Rightarrow \hat{L} = QL = Q, \tag{6.124b}$$

where Q is the equivalent of P in the three-dimensional isotopy of $SU(2)$ for the case of the angular momentum. Note that *hadronic mechanics remains isounitary for all the above infinitely possible eigenvalues of spin and angular momenta, thus including fractional values of angular momenta as a particular case of a much broader class.*

The *spin of the neutron* is given by the sum of the isotopic realizations of the intrinsic and orbital angular momentum of the proton and isoelectron with isoeigenvalues (see the 1990 paper for details)

$$\begin{aligned} \hat{S}_n^2 T|\hat{s}\rangle &= \hat{S}_n T \hat{S}_n T|\hat{s}\rangle = \\ &(S_p + PS_e + QL_e)(S_p + PS_e + QL_e + 1)|\hat{s}\rangle = (3/4) \times |\hat{s}\rangle, \end{aligned} \tag{6.125a}$$

$$\hat{S}_{n,3} T|\hat{s}\rangle = (S_p + PS_e + QL_e)|\hat{s}\rangle = \pm(1/2)|\hat{s}\rangle, \tag{6.125b}$$

$$\hat{J}_{e, \text{Tot}, 3} T|\hat{s}\rangle = (S_n + PS_e + QL_e)|\hat{s}\rangle = 0. \tag{6.125c}$$

Since the proton is much heavier than the electron, it can be considered at rest in first approximation, thus having conventional (quantum) spin 1/2 as indicated in Figure 6.11. Also, as indicated earlier, the electron can only have a stable

coupling with the proton in singlet. Therefore, the electron has spin $-1/2$ in the configuration of Figure 6.11. It then follows that the only possible solution is that indicated earlier, for which the spin of the neutron coincides with that of the proton, and the isoelectron has null total angular momentum:

$$S_n = S_p = 1/2, \quad J_{\hat{e}} = 0. \quad (6.126)$$

The invariant isounitary representation of the spin of the neutron via the isotopies of $SU(2)$ -spin is then characterized by the values (see again Santilli's 1990 paper for details)

$$PS + QL = P/2 + Q = 0, \quad Q = -P/2, \quad (6.127a)$$

$$P = 1, \quad Q = -1/2. \quad (6.127b)$$

It should be noted that *in a more realistic model all angular momenta of the electron and of the proton are mutated, thus implying eigenvalues that are not necessarily integer or half-off-integer.*

Note also the necessity of the isotopies for the achievement of an exact and invariant representation of the spin of the neutron. Note finally the *direct universality* of the above isotopies of $SU(2)$ -spin, in the sense that any other nonunitary realization is equivalent to the preceding one.

6.3.D *Nonrelativistic, exact and invariant representation of the neutron magnetic moment*

In this section we review the original, nonrelativistic, exact and invariant representation of the magnetic moment of the neutron,

$$\mu_n = -1.913\mu_N, \quad (6.128)$$

from those of the proton and of the isoelectron also achieved for the first time in Santilli 1990.

Recall from the preceding sections that: the spin of the neutron coincides with that of the proton; the isoelectron's spin is antiparallel to that of the proton; and the orbital angular momentum of the isoelectron is parallel to that of the proton spin, yet the magnetic moment it creates is antiparallel due to the negative charge. Recall also that the intrinsic magnetic moment of the electron when isolated in vacuum is much bigger than that of both the proton and the neutron because

$$1 \mu_B = 1836.151\mu_N. \quad (6.129)$$

The magnetic moment of neutron is characterized by *three* contributions: the magnetic moment of the proton; that of the isoelectron; and that caused by the orbital motion of the isoelectron. Note that the third contribution is completely

missing in quantum mechanics because all particles are considered as massive points, in which case the electron cannot rotate *inside* the proton. As Santilli states: *I believe that the inability by quantum mechanics to treat the orbital motion of the electron inside the proton, with consequential failure to represent the anomalous magnetic momentum of the neutron, was the very origin of the conjecture of the neutrino.*

With reference to the orientation of Figure 6.11, and by keeping in mind that a change of the sign of the charge implies a reversal of the sign of the magnetic moment, the derivation of Santilli 1990 is based on the identity

$$\mu_n = \mu_p + \mu_{\hat{e}, \text{Intrinsic}} - \mu_{\hat{e}, \text{Orbital}} = -1913\mu_N. \quad (6.130)$$

Since the spin of the proton and of the electron can be assumed to be conventional in first approximation, we can assume that the magnetic moments of the proton and of the isoelectron are conventional, i.e.,

$$\mu_{\hat{p}} = \mu_p = +2.793\mu_N, \quad (6.131a)$$

$$\mu_{\hat{e}} = \mu_e = -1.001\mu_B = 1837.987\mu_N, \quad (6.131b)$$

$$\mu_p + \mu_{\hat{e}} = 1835\mu_N. \quad (6.131c)$$

It is then evident that *the anomalous magnetic moment of the neutron originates from the magnetic moment of the orbital motion of the isoelectron inside the proton, namely, a contribution that has been ignored since Rutherford's time until treated in Santilli 1990.*

It is easy to see that the *exact and invariant representation of the anomalous magnetic moment of the neutron* is characterized by the following numerical values

$$\mu_{\hat{e}, \text{Orbital}} = +1.004\mu_B, \quad (6.132a)$$

$$\mu_{\hat{e}, \text{Total}} = 3 \times 10^{-3}\mu_B, \quad (6.132b)$$

$$\mu_n = -1913\mu_N, \quad (6.132c)$$

and this completes our review of the nonrelativistic representation of the neutron characteristics. Note that the small value of the total magnetic moment of the isoelectron is fully in line with the small value of its total angular momentum (that is null only in first approximation due to the assumed lack of mutation of the proton).

6.3.E Foundations of the relativistic treatment

Santilli achieved the first relativistic invariant and exact representation of all characteristics of the neutron as a "compressed hydrogen atom" in the 1993 paper [82] written while visiting the *Joint Institute for Nuclear Research* in Dubna,

Russia, and published in [90]. The achievement was based on preceding extensive studies on the *isotopies of the Minkowski space, the Lorentz-Poincaré symmetry and special relativity* summarized in the 1991 monographs [9, 10] (see [22] for a 2008 update).

In his 1993 paper, Santilli achieved the first correct and time invariant isotopies of Dirac equation, and proved its validity by providing the indicated relativistic representation of the neutron synthesis.

Relativistic hadronic mechanics and the isotopies of Dirac equation have been outlined in Section 3.11Q. We discourage the reader from inspecting this section without an in depth knowledge of relativistic hadronic mechanics to prevent the possible illusion of valid criticisms. We merely recall for notational scopes that relativistic hadronic mechanics requires at least *two isotopies*, one for spacetime and one for spin, plus possible additional isotopies, e.g., for internal isounitary symmetries (see later on in this chapter). These isotopies are uniquely characterized by the Lie-Santilli isothory with the two isounits (3.221), e.g.,

$$\widehat{I}_{st} = 1/T_{st} = \text{Diag.}(n_1^2, n_2^2, n_3^2, n_4^2) = U_{4 \times 4} U_{4 \times 4}^\dagger = 1/T_{st}, \quad (6.133a)$$

$$\widehat{I}_{spin} = 1/T_{spin} = \text{Diag.}(s_1^2, s_2^2) = U_{2 \times 2} U_{2 \times 2}^\dagger = 1/T_{spin}. \quad (6.133b)$$

The isounit for spacetime (st) characterizes the Minkowski-Santilli isospace and the isospinorial Lorentz-Poincaré-Santilli isosymmetry, while the spin isounit characterizes the isotopic spin symmetry.

The isolarization of the second order isoinvariant then yields the invariant isotopies of Dirac's equation, today known as the *Dirac-Santilli isoequation* (3.203), i.e.,

$$\begin{aligned} U_{4 \times 4} \left[\gamma^k (p_k - ieA_k) - i\widehat{m}C \right] |e\rangle U_{4 \times 4}^\dagger = \\ \left\{ \widehat{G}^k T_{4 \times 4} \left[\widehat{p}_k - (\widehat{ieA}_k) \right] - (\widehat{i\widehat{m}C}) \right\} T_{4 \times 4} |\widehat{e}\rangle = \\ \left[\widehat{\gamma}^k (\widehat{p}_k T_{4 \times 4} - ieA_k) - i\widehat{m}C \right] |\widehat{e}\rangle = 0, \end{aligned} \quad (6.134a)$$

$$\widehat{G}^k = \widehat{\gamma}^k \widehat{I}_{st}, \quad \widehat{\gamma}^k = U_{4 \times 4} \gamma^k U_{4 \times 4}^\dagger, \quad (6.134b)$$

$$\{\widehat{\gamma}^i, \widehat{\gamma}^j\} = U_{4 \times 4} \{\gamma^i, \gamma^j\} U_{4 \times 4}^\dagger = \widehat{\gamma}^i T_{4 \times 4} \widehat{\gamma}^j + \widehat{\gamma}^j T_{4 \times 4} \widehat{\gamma}^i = \widehat{m}^{ij}. \quad (6.134c)$$

At this point, the reader should have a technical knowledge of the following aspects treated previously:

1) The *conventional* Dirac equation is not a two-body equation like the Schrödinger equation for the hydrogen atom, but represents *one electron moving in vacuum under the external field of a proton*. Consequently, the *Dirac-Santilli isoequation* represents the electron while being completely immersed within the

hyperdense hadronic medium considered as external. Hence, the transition from the Dirac equation to the Dirac-Santilli isoequation is an effective way to reach a quantitative representation of the mutation of particles second only to the transition from the spinorial covering Lorentz-Poincaré symmetry to its isotopic covering outlined in Sections 3.10 and 3.11Q.

2) Santilli has strenuously opposed the idea that a particle in the core of a collapsing star has the same intrinsic characteristics (spin, charge, magnetic moment, etc.) as when nicely free in vacuum, as detected until now. Consequently, he has constructed relativistic hadronic mechanics for the quantitative studies of the biggest possible *deviations* of the intrinsic characteristics of particles when in vacuum. This is the general case of the Dirac-Santilli isoequation and its underlying Pauli-Santilli isomatrices reviewed in Section 3.11Q.

3) Since the proton is about 2000 times heavier than the electron, the synthesis of the neutron can be well assumed as being a realization of the Dirac-Santilli isoequation without any mutation of the intrinsic characteristics. This feature was first well established by Santilli in his nonrelativistic analysis, and then adopted for the relativistic study as being valid to first order. Hence, the Pauli-Santilli isomatrices used in the neutron synthesis are indeed lifted, but they admit conventional eigenvalues for spin 1/2.

By using the above theoretical and experimental foundations previously established in vast studies (Chapters 1, 2, 3, 4, 5), Santilli relativistic, exact and invariant representation of *all* characteristics of the neutron in its synthesis from a proton and an electron is elementary and can be summarized as follows.

6.3.F *Relativistic, exact and invariant representation of the neutron rest energy, meanlife and charge radius*

Recall that the characteristic quantities of the spacetime isounit are not arbitrary parameters such as those used to adapt nature to a preferred theory (e.g., as it is the case for the chaoticity parameters to of the Bose-Einstein correlation), but represent actual, experimentally measured physical characteristics of hadrons.

In fact, the space characteristic quantities n_k , $k = 1, 2, 3$, represent the actual *dimension and shape* of the neutron by characterizing its semiaxes normalized to the value 1 for the perfect sphericity. Similarly, the fourth characteristic quantity n_4 represents the *density* of the neutron (defined as the ratio between the rest energy and the volume) normalized to the value 1 for the vacuum, as done for the index of refraction.

In his nonrelativistic 1990 paper, Santilli assumes the neutron is perfectly spherical and that the spin of the isoelectron is conventional. However, in the relativistic treatment of 1993, Santilli no longer assumes the neutron as being perfectly spherical, with consequential mutation of the spin, and assumes the

numerical value of the neutron density n_4 from the best data available at that time, the representation of the Bose-Einstein correlation via hadronic mechanics, Eqs. (5.69), i.e.,

$$n_4 = 0.605, \quad n_4^2 = 0.366. \quad (6.135)$$

A fundamental function of Santilli isorelativity is that of characterizing the *isorenormalization of the rest energy*, namely, the mutation of the conventional value of the rest energy of a particle when immersed within a hyperdense medium, according to Isoaxiom V (Section 3.10)

$$E_{\hat{e}} = m_e c^2 / n_4^2. \quad (6.136)$$

The use of the above experimental value of the neutron density then yields the *representation of the rest energy of the isoelectron*

$$E_{\hat{e}} = m_e c^2 / n_4^2 = 1.396 \text{ MeV}, \quad (6.137)$$

from which Santilli obtains the *exact and invariant representation of the rest energy of the neutron*

$$E_n = E_p + E_{\hat{e}} + \text{BE} = 939 \text{ MeV} \quad (6.138)$$

with *negative binding energy*

$$\text{BE} = -0.104 \text{ MeV}, \quad (6.139)$$

while for conventional quantum mechanics the representation of the mass of the neutron would require the anathema of a “positive binding energy.” It should be stressed that the above binding energy is entire of Coulomb origin due to the *attraction* between the proton and the isoelectron, since the strong hadronic forces are nonpotential and, consequently, they cannot characterize any binding energy.

Santilli also notes that value (5.69) represents the density of the proton-anti-proton fireball in the Bose-Einstein correlation, which density is expected as being bigger than that of the neutron. Under the assumption of a null potential energy Santilli gets the limit values

$$n_4 = 0.629, \quad n_4^2 = 0.396, \quad (6.140a)$$

$$E_n = E_p + E_{\hat{e}}, \quad \text{BE} = 0, \quad (6.140b)$$

that recovers the nonrelativistic result in first approximation

$$E_{\hat{e}} = 1.292 \text{ MeV} = E_n - E_p. \quad (6.141)$$

The relativistic, exact and invariant representation of the meanlife and charge radius was done in Santilli 1993 from the radial component of the Dirac-Santilli isoequation, thus being similar to the nonrelativistic and its review is omitted here for brevity.

6.3.G *Relativistic, exact and invariant representation of the neutron spin*

Recall from Figure 6.11 that, under the assumption that the proton is unmutated, the representation of the spin of the neutron requires that the total angular momentum of the isoelectron is null, namely, that its spin is identical in absolute value, yet opposite to the mutated angular momentum. In his 1993 paper, Santilli readily verified this condition via the use of the isotopies of the angular momentum studied in Section 3.11Q for which

$$\widehat{L}^2 T|\widehat{e}\rangle = (n_1^2 n_2^2 + n_2^2 n_3^2 + n_3^2 n_1^2)|\widehat{e}\rangle = \widehat{J}^2 T|\widehat{e}\rangle = (1/4)(n_1^{-2} n_2^{-2} + n_2^{-2} n_3^{-2} + n_3^{-2} n_1^{-2})|\widehat{e}\rangle, \quad (6.142a)$$

$$\widehat{L}_3 T|\widehat{e}\rangle = (-n_1 n_2)|\widehat{e}\rangle = \widehat{J}_3 T|\widehat{e}\rangle = \pm(1/2)(n_1^{-1} n_2^{-1})|\widehat{e}\rangle, \quad (6.142b)$$

with algebraic solution

$$n_1^2 = n_2^2 = n_3^2 = 1/\sqrt{2}, \quad (6.143a)$$

$$\widehat{L}^2 = \widehat{S}^2 = 3/2, \quad (6.143b)$$

$$|\widehat{L}_3| = |S_3| = 1/\sqrt{2}. \quad (6.143c)$$

Note not only the mutated values of the third components, but also those of the magnitudes of conventional angular momentum. Note also that the relationship between the mutated values of the third components and those for the magnitudes are not conventional, as apparently necessary for the constrained conditions of the electron trapped inside the proton.

Note finally the *exact and invariant* character of the solution, since it is based on the isotopies of the rotational and spin symmetries achieved for the first time in Santilli 1993.

6.3.H *Relativistic, exact and invariant representation of the anomalous magnetic moment of the neutron*

Recall from Section 3.11Q that the Dirac-Santilli isoequation characterizes the following *isotopies of the magnetic and electric dipole moments*,

$$\widehat{\mu} = \mu n_4/n_3, \quad \widehat{d} = d n_4/n_3. \quad (6.144)$$

The above laws provide a technical representation of the well known semiclassical property that the deformation of a charged and spinning sphere necessary implies an alteration of its magnetic moment. In particular, we have a decrease (increase) of the magnetic moment when we have a prolate (oblate) deformation or when we decrease (increase) the angular momentum.

Recall that the total magnetic moment of model of Figure 6.11 requires three contributions,

$$\mu_n = \mu_p + \mu_{\hat{e}, \text{Intrinsic}} - \mu_{\hat{e}, \text{Orbital}} = -1.9123\mu_N. \quad (6.145)$$

Recall also from the Dirac-Santilli isoequation studied in Section 3.11Q that the intrinsic magnetic moment of the isoelectron is mutated into the expression

$$\mu_{\hat{e}, \text{Intrinsic}} = \mu_e n_4 / n_3, \quad (6.146)$$

where now both characteristic quantities n_4 and n_3 are known. In this way, Santilli reached the following relativistic, exact and invariant representation the *intrinsic magnetic moment of the isoelectron*

$$\mu_{\hat{e}, \text{Intrinsic}} = 0.8545\mu_e. \quad (6.147)$$

The desired representation of the anomalous magnetic moment of the neutron is then given by the following *orbital magnetic moment of the isoelectron*

$$\mu_{\hat{e}, \text{Orbital}} = 0.8521\mu_{\hat{e}, \text{Intrinsic}}. \quad (6.148)$$

Note the *decrease* of the intrinsic magnetic moment of the electron that is fully in line with the decrease of the third spin component from $1/2$ to $1/\sqrt{2}$. Note also that the above values are different than the corresponding nonrelativistic expressions because in the latter treatment Santilli assumed in first approximation that the spin, and, consequently, the intrinsic magnetic moment of the electron are not mutated. At a relativistic level a mutation of both spin and magnetic moment does occur. Such a result could be predicted by the underlying symmetry, the Lorentz-Poincaré-Santilli isosymmetry, for which the mutation of one intrinsic characteristic of a particle generally implies that of all others.

6.3.I Santilli's etherino vs Fermi's neutrino

As the attentive reader may have noted, the need for the emission in the neutron synthesis of a neutrino emerges nowhere at both the non relativistic and relativistic levels. This aspect is best clarified by Santilli's recollections released for this book:

As it is well known, the word "neutrino" is an Italian name proposed by Enrico Fermi to mean "little neutron." Being a physicist born and educated in Italy, Enrico Fermi was and remains my scientific star, particularly in view of my research on new clean nuclear energies.

However, with the passing of time, I grew more and more uneasy about the hypothesis of the emission of a neutrino in the neutron synthesis inside stars

$$p^+ + e^- \Rightarrow n + \nu. \quad (6.149)$$

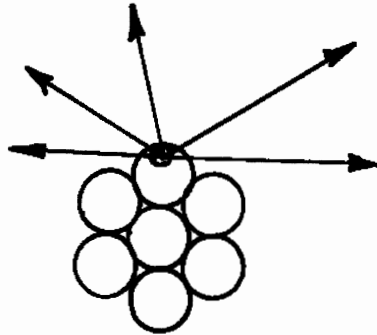

Figure 6.12. Reproduction of a drawing used by Santilli to illustrate that the variation of the kinetic energy in nuclear beta decay is due to the Coulomb interaction between the positively charged nuclei and the negatively charged electron, being maximal for radial emission and minimal for tangential emissions. This results in the well known bell-shaped behavior of the kinetic energy of the emitted electron with no energy at all to permit the very existence of the neutrino.

Of course, I understood fully the need for the neutrino hypothesis, in whose absence we have violations of conservation laws noted also by Pauli. However, nature is not that simple as all of us dream and, as a physicist, I needed clean quantitative evidence establishing the existence of the neutrino independently from my unbounded respect for Pauli, Fermi and the other founders of our physical knowledge.

My first difficulties dealt with the identification of the energy needed to emit a neutrino in nuclear beta decays. The difficulty is representative of the dichotomy quantum vs hadronic mechanics. For quantum mechanics, nuclei are points, in which case the neutrino hypothesis is necessary to salvage conservation laws.

However, for the covering hadronic mechanics, nuclei are represented as they are in the physical reality, extended and actually very large bodies for particle standards. It is then easy to see that, following the beta decay, electrons remain attracted by nuclei due to their opposite charges and, consequently, the electron energy is a function of their direction of emission, being maximal for radial emissions and minimal for tangential emissions, resulting in the experimentally detected bell-shaped curve of the energy of the electron. The (rather primitive for today's knowledge) 20th century nuclear physics assumed that the variation of energy inherent in such a bell-shaped behavior was "evidence" of the emission of the neutrino. However, specific calculations based on extended nuclei and nuclei-electron attractions then left no energy at all for the very existence of the neutrino. I then started to have serious doubts on the existence of neutrinos as physical particles in our spacetime.

When I conducted in the 1980s systematic studies on the synthesis of the neutron from protons and electrons, my doubts on the existence of the neutrino grew considerably because I found the same dichotomy of quantum vs hadronic mechanics. In fact, Fermi had to assume the proton as being dimensionless because requested for the very consistency of quantum mechanics. Under such an assumption, the hypothesis of the neutrino is, again, necessary.

However, when studying the synthesis of the neutron with the covering hadronic mechanics, the situation is substantially different because, as soon as the extended character of the proton is admitted, the "orbital" angular momentum of the electron in its "compression" inside the proton is unavoidable. But the proton is hyperdense. Hence, the electron is constrained to orbit inside the proton along its spin, since other views would imply that the electron orbits inside the hyperdense proton against its spin, resulting in very implausible conditions.

Additionally, the proton and the electron can solely couple in singlet to prevent very strong repulsive forces of triplet coupling of extended particles one inside the other. I reached in this way in the mid 1980s the conclusion that the total angular momentum of the electron when immersed inside the proton is identically null because its spin is equal and opposite to its angular momentum. Consequently, the spin of the neutron coincides with that of the proton, without any possibility of identifying the neutrino anywhere.

As it is well known, half-odd-integer angular momenta are prohibited by the rotational symmetry $SO(3)$ of quantum mechanics because they would violate unitarity, causality, and all that. However, the covering Lie-Santilli antisymmetry $\widehat{SO}(3)$ I had presented in my original 1978 memoir and studied subsequently in detail, readily admits half-odd-integer angular momenta in a fully invariant and causal way. As a matter of fact, the angular momentum in hadronic mechanics may have "continuously varying values" to prevent the theology that an electron in the core of a star can have the same discrete orbits as when isolated in vacuum.

More technically, in the transition from quantum to hadronic mechanics, Planck's constant \hbar is replaced by the integral-differential isounit $\widehat{I}(t, r, p, \psi, \dots)$ which becomes the basic unit of the Lie-Santilli isosymmetry $\widehat{SO}(3)$. Continuously varying, fully invariant and causal angular momenta are then a consequence of the locally varying character of the isounit. Invariance is guaranteed by the fact that the unit is the basic invariant of any theory.

Following the achievement of the above technical knowledge, I was ready in the late 1980s to release for publication my first paper on the nonrelativistic representation of all characteristics of the neutron, thus including its spin, as a hadronic bound state of a mutated proton and a mutated electron. A big dilemma soon emerged in writing the paper, whether I should disclose or not my view on the apparent lack of existence of the neutrino.

Since at that time I was dreaming of publishing such an innovative paper in a refereed journal, I decided to keep silence on the issue of the neutrino, with the intent of disclosing my doubts later on. Rutherford had published his conception of the neutron in the *Proceedings of the Royal Society*, Vol. 97, 1920, page 374 on. It is customary in physics to publish further advances in the journal of the origination of the idea. Hence, I submitted in 1988 my paper to the *British Proc. Roy. Soc.* in respect of Rutherford's memory because, after all, Rutherford had conceived the neutron as a bound state of a proton and an electron, to be later on dismissed by Pauli and others because impossible for quantum mechanics.

I still remember the months and months of fights with the editorial board of the *Proc. Roy. Soc.* to no avail. I was praying them to consider the paper in Rutherford's honor, I brought to their attention the potentially large societal implications for new clean energy, I appealed to scientific democracy for qualified inquiries because, after all, I had indeed proved the plausibility of Rutherford's original conception of the neutron as a bound state of a proton and an electron, all this to no avail. Rutherford's conception of the neutron required a necessary nonunitary generalization of quantum mechanics into hadronic mechanics and this occurrence caused clear hysteria in the editorial board of the *Proc. Roy. Soc.* to such a level to be offensive toward the memory of one of their most illustrious compatriots.

Still dreaming of publishing the paper in a conventional journal, I then submitted it to the journals of the Italian, American and other societies without disclosing my doubts on the existence of the neutrino, thus by using Fermi's reaction (6.149). The rejections used such strong language due to the surpassing of quantum mechanics to qualify as delicate in comparison the rejections by the *Proc. Roy. Soc.* To avoid that decades of research were wasted, I then published the paper in 1990 in the *Hadronic Journal* [62].

I was so discouraged by the absence of scientific contents of all these reviews that, as one can verify, I published the paper in the latest available form, that without any mention of the neutrino problem, thus with a clear inconsistency between the use of Eq. (6.149) showing a neutrino and Figure 6.11 of the paper showing lack of its need.

Despite these academic shortcomings, my uneasiness with the neutrino hypothesis grew deeper the deeper I studied the issue. I noted that, indeed, the Lorentz-Poincaré (LP) symmetry does require the "independent" conservation of the total linear and total angular momenta. However, such a symmetry solely holds for Keplerian systems, that is, for isolated masses moving in vacuum without contact or collisions all around a heavier Keplerian nucleus. I could not possibly accept the validity of the Lorentz-Poincaré symmetry for the structure of the neutron, I never did and never will, because the structure of the neutron does not admit a Keplerian center.

Hence I spent decades for the construction of covering symmetry specifically conceived for non-Keplerian systems such as the neutron, today known as the Lorentz-Poincaré-Santilli (LPS) isosymmetry. It was then easy to see rather radical changes in the transition from the LP to the LPS symmetry. In fact, the LP symmetry requires isolated point-masses particles moving in empty space without contact or collisions. By comparison, the LPS symmetry was conceived for particles totally immersed one inside the other, thus including inevitable constraints.

The technical characterization of the neutron constituents as (iso)-unitary irreducible (iso)-representations of the LPS symmetry, the isoprotons and the isoelectrons, confirms fully the lack of any need for the neutrino hypothesis to such an extent that its presence caused catastrophic inconsistencies. To begin, for an isolated neutron, the conservation of the linear and angular momenta of its constituents has no physical meaning, the sole conservation law being that of the total energy and the uniform motion of the center of mass.

Additionally, that constrained systems admit the transformation of linear into angular momenta and viceversa, as it is typically the case of a "sling shot", each physical quantity represented in the conservation of the total energy. Consequently, in the neutron synthesis, constraints cause the transformation of linear into angular momenta without any need to emit a neutrino for both the neutron synthesis and its spontaneous decay.

Despite these personal convictions, I published all additional relativistically and relativistic papers on the structure of the neutron in 1992, 1993 and 1995 by using Fermi's hypothesis on the neutrino without any mention of my doubts on its existence. This was due in part to my reverence for Enrico Fermi but also to my long experience that novelty in academia is the enemy to destroy at whatever cost. Since the neutrino hypothesis was deeply rooted in all segments of the physics of the time, from prep courses to large grants for very costly "neutrino detectors," I elected to keep my doubts to myself, yet my papers based on reaction (6.149) were structurally inconsistent because of the redundancy of spin $1/2$, something no reviewer noted.

Yet, my uneasiness on the neutrino hypothesis kept growing in time and so did the disparity between my views and the so-called "mainstream neutrino physics." On theoretical grounds, Fermi's original conception of one massless and chargeless neutrino and one antineutrino was first enlarged to three different neutrinos (the electron, muon and tau neutrinos) and three antineutrinos although without any clear structural, experimentally measurable distinction, since flavor and other $SU(3)$ features cannot be defined in our spacetime.

This enlargement turned out as being insufficient "to fix things," namely, to achieve compatibility with the standard model. Hence, the three neutrinos and three antineutrinos were assumed to have "masses" used for fitting data. This broadening of Fermi's original conception was and remains unacceptable to me

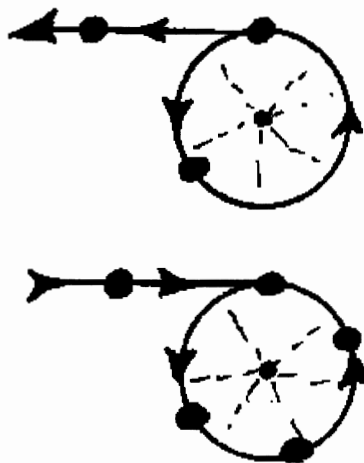

Figure 6.13. Reproduction of the original drawing made and used by Santilli to illustrate the absence of a neutrino in both the neutron synthesis and its decay. In the neutron synthesis in the core of a star (bottom view) the linear momentum of the electron is constrained to be turned into its angular momentum when compressed inside the proton. In the spontaneous decay of the neutron, we have the opposite event in which the constrained angular momentum is transformed into the linear momentum of the expelled electron, its spin being not mutated in first nonrelativistic approximation in both cases.

because I already had difficulty in accepting that a massless particle could traverse entire planets and stars, that is, pass through the hyperdense media of something like 10^{10} nuclei without collision. But then, I could not possibly accept and never will accept as plausible idea that massive neutrino can pass through 10^{100} superdense nuclei without appreciable collision.

Then the hypothesis of three different massive neutrinos and three different massive antineutrino turned out as being still insufficient for achieving compatibility with the standard model. Hence, the so-called "main stream neutrino community" ventured the additional conjecture, immediately accepted by journals of all physical society around the world because proffered by high ranking physicists, that "neutrino oscillates" (loosely speaking different neutrinos can transform into each other).

My increasing uneasiness was due to the fact that one experimentally unverifiable but insufficient conjecture was being replaced with a broader equally unverifiable conjecture to fix the preceding one. When the new conjecture turned out as being insufficient, a yet broader, equally unverifiable conjecture was voiced. Consequently, I asked myself the question: when will this chain of unverifiable conjectures stop? Clearly the field requires a profound structural revision to regain plausibility since the maintaining of the theoretical status quo is no longer tenable.

On experimental grounds, my uneasiness on neutrino conjectures was even greater than that for theoretical profiles. Fermi had clearly stated that “neutrinos cannot be directly detected,” evidently because they were assumed as being massless and chargeless. I still remember the first serious effort at the detection of neutrinos done in the 1980s in Italy with the construction of the “Gran Sasso Laboratory,” consisting of a very large chamber excavated under the Gran Sasso Mountain in the Central Apennines, that was filled up with distilled water and equipped with various detectors. The laboratory was set up for the intent of detecting hypothetical events caused by neutrinos coming from the opposite side of Earth, while the Gran Sasso mountain was intended as a shield for cosmic rays and other radiation. Following five years of measurements, the laboratory produced no measured event worth considering.

Rather than initiating a serious re-inspection of the foundations of the neutrino conjectures, the “mainstream neutrino community” immediately reacted in the late 1980s with the granting of Nobel prizes for the “discovery of neutrinos” after which any physicist claiming of their lack of existence was in need of psychiatric assistance for the establishment. “Experimental neutrino physicists” also moved to the attack of canceling the debacle caused by the Gran Sasso Laboratory with the design of bigger and bigger “neutrino detectors” that, as such, required bigger and bigger public funds.

Evidently, I always accepted the data originating from these “neutrino experiments” as real. That’s not the issue. The issue is the “interpretation” of these data via neutrino conjectures since alternative interpretations are indeed possible, and one among others will be indicated shortly. I could not possibly accept these interpretations because of:

- 1) The extremely few events in “neutrino detections” over an extremely large number of events, thus having statistics insufficient for a final experimental claim.*
- 2) The new “neutrino detectors” often contain radioactive isotopes whose decay could itself cause the very few events assumed as being “evidence of neutrinos,” while being in reality events prohibited by quantum mechanics yet fully permitted by the covering hadronic mechanics, such as certain stimulated double beta decays.*
- 3) The elaboration of the data was based on the assumption of the exact validity of the LP symmetry under conditions it was expected as being inapplicable, as it was eventually verified.*

The main issue is that, on strict scientific grounds, all the past and ongoing neutrino experiments are indeed valuable, but they cannot claim direct detection of neutrinos, as stated by Fermi. These experiments essentially identify physical particles in our spacetime whose production is merely conjectured as being due to neutrinos. Once the indirect character of the detection is admitted, one can see the possibility of alternative interpretation of exactly the same experimental

data with new theories without the litany of problems of neutrino conjectures, a process that is indeed under way at this writing (summer 2010).

My uneasiness on neutrino conjectures reached uncontrollable levels when I started to apply the preceding results to astrophysics, with particular reference to the study of the synthesis inside stars of light , natural, and stable element. As it is well known, the synthesis of the neutron requires 0.782 MeV (for which value there is no energy at all for the neutrino). The evident question was: where is this energy coming from?

As well known, a star initiates its life as large aggregates of hydrogen, first synthesizes neutrons from hydrogen atoms, and then synthesizes the deuterium, the helium and all other natural isotopes. The important point is that the first synthesis of neutrons "requires" energy, energy being "released" only in the subsequent nuclear syntheses.

It was easy to see that the missing 0.782 MeV per neutron cannot originate from the star itself. In fact, at the majestic initiation of its life, even a small star can synthesize 10^{50} neutrons per seconds. In the event the missing 0.782 MeV per neutron originated from the star interior, the star could not possibly initiate emitting light because it would "lose" 10^{50} MeV per seconds and produce no light.

These and other astrophysical considerations confirmed all my uneasiness on neutrino conjectures because I was clearly facing with the need for a structurally new approach to the neutron synthesis. In 2005 I received the visit at IBR in Florida of a distinguished, high ranking colleague (whose name I cannot disclose to prevent that his academic and personal lives be disrupted by neutrino fanatics). Since we knew and respected each other for decades, I decided to download on him all my doubts on neutrino conjectures. To my surprise, he shared them all and indicated that he too had elected to be silent to prevent hysterical reactions by neutrino fanatics. He also indicated that numerous other important physicists (whose names I also cannot disclose) had serious doubt on the neutrino business, a rather widespread condition among serious physicists.

That was it! The awareness that I was far from being alone for my doubts on neutrino conjectures gave me strength to publish my ideas. I plunged myself in the writing of the first paper on the neutron synthesis without neutrino, I presented the content at the 2006 meeting of the "International Association of Relativistic Dynamics" (IARD) held at the University of Connecticut in Storrs, I saw the plausibility of the ideas in the eyes and comments of the audience, and published in 2007 the paper [123].

The main content is that, since the missing energy cannot plausibly originate from the star itself, it originates from space conceived as a universal medium of very high density (the historical ether) necessary not only for the existence and propagation of electromagnetic waves (no "wave" can possibly exist without a "medium"!) but also for the existence and propagation of truly elementary parti-

cles such as the electron and, therefore, of all matter at large. I then introduced a new entity under the name “etherino” with symbol “a” (from the Latin “aether”) and proposed the following alternative to reaction (6.149)

$$p^+ + a + e^- \Rightarrow n, \quad (6.150)$$

with the isodual expression for the antineutron

$$p^- + a^d + e^+ \Rightarrow n^d. \quad (6.151)$$

To prevent the already large zoo of unknown particles, I stressed in the 2007 paper that the etherino was “not” proposed as being a particle. but was merely intended to represent the transfer of energy and other quantities from the ether to the neutron. I also indicated the new meaning of hadronic mechanics as permitting a quantitative study of the ether as a universal substratum with high energy density and its interaction with visible matter. In fact, the etherino cannot even be conceived with conventional, quantum Hilbert spaces over conventional fields, and necessarily require the covering Hilbert-Santilli isospaces over isofields.

Contrary to superficial impressions without prior technical knowledge, the connection between Fermi’s neutrino and Santilli’s etherino is quite deep. In fact, the synthesis of the neutron requires a third entity in the left-hand-side, according to Fermi’s hypothesis (6.149)

$$p^+ + \nu^d + e^- \Rightarrow n. \quad (6.152)$$

Comparison of reactions (6.150) and (6.152) shows that they may eventually result as being the same. However, the “interpretation” changes dramatically. Fermi’s neutrino is assumed as being a physical particle in our spacetime with consequential great uneasiness at the idea that neutrinos could traverse something like 10^{100} hyperdense nuclei without appreciable collisions.

By contrast, Santilli’s etherino is an impulse propagating through the ether that, as such, can indeed cross 10^{100} hyperdense nuclei because the propagation is in the underlying medium and not through matter. In short, I conceived the etherino to remove the biggest implausibility of neutrino conjectures, while preserving experimental data as indicated below.

It has to be of “longitudinal” character (potentially it would be an ordinary electromagnetic wave), thus resolving the uneasiness of traversing entire planets and stars without collisions because the propagation occurs in the underlying universal medium.

Subsequently, I initiated astrophysical studies still under way to discover a number of events that appear to require more energy than that contained in stars, thus requiring the acquisition of energy from the ether. One of them is the supernova explosion generally occurring at the end of life of a star. It is evident that the star still remains as a large reservoir of fusion energy. However, calculations show

that such a reservoir is grossly insufficient to explain the immensity of the energy in the explosion of a supernova that remains visible to the naked eye at billions of light years distances. The only numerical explanation I could come out in this case is that supernovas somehow trigger the transfer of immense energies from the ether to our visible world.

Additionally, these astrophysical studies brought again to my attention the old, fascinating theories of the "continuous creation" in the universe. It was then immediate to see that the etherino is essentially an alternative formulation of continuous creation, since it carries energy from the ether, thus energy that did not previously exist in our physical world. By studying deeper and deeper these astrophysical aspects, I became convinced that all stars are indeed a source of continuous creation in the sense that they have mechanisms for extracting energy from the ether.

Electromagnetic waves are known to be transverse. Hence, the neutrino could not be characterized by an equally transverse oscillation of the ether otherwise it would be an ordinary photon with a host of sequential inconsistencies in reaction (6.150). This and other aspects suggested that the etherino is expected as being a "longitudinal" impulse propagating through the ether. It is then possible to see that exactly the same experimental data on "neutrino detections," as available, can be identically re-elaborated via the etherino hypothesis.

Far from being a mere scientific curiosity, the implications are very intriguing indeed. In fact, currently available experimental data on neutrino events could be the type of a big scientific iceberg yet to uncover, the discovery of a new form of communication through space that, being longitudinal, is expected as being millions of times faster than the speed of electromagnetic waves. Hence, future generations of scientists have the possibility of establishing a new form of very rapid interstellar communication for which electromagnetic waves are similar to the smoke signals used by American Indians.

In closing, a most rewarding personal aspect is that, after such a long scientific journey that required new mathematics, new physics, new experiments and all that, I was forced to go back to the first paper [29] I wrote when still a high school student and published during my first year of physics courses, where I presented the conception of the ether as a universal medium of great rigidity (because electromagnetic waves are transverse) and the elimination of the "ethereal wind" used at the time to deny its existence. The latter was achieved by noting that the electron is a "pure oscillation" with the frequency of 0.829×10^{20} Hz, that is, an oscillation without a "little mass" oscillates in its interior. Consequently, the oscillation can only be realized by a point of the ether. When an electron is moved, its characteristic oscillation is moved from a region of the ether to another, and no "ethereal wind" is conceivably possible. The paper then extrapolated this basis features to matter at large. Inertia was conceived as the resistance by the ether

against accelerations. Already at my first year undergraduate course of physics I dismissed any intrinsic value to mass, and considered its energy equivalent as the really basic characteristics.

According to this view, the universal substratum is necessary for the very existence as well as of propagation of all visible entities, including electromagnetic waves, elementary particle and matter at large, because waves, oscillations, strings and all that cannot plausibly exist without a medium.

In short the 2007 paper confirmed my 1956 paper on the ether as a truly universal substratum to the effect that, contrary to our sensory perception, matter is totally "empty" in the sense that there is no "little solid" oscillating in the structure of the electron and other elementary particles, and space is totally "full" in the sense that it is a universal medium of extremely high density filling up the entire universe with no voids nowhere.

6.3.J Structure model of the remaining baryons with physical constituents

Santilli extended the results of his structure model of the neutron to the octet of baryons in the 1997 memoir [99] resulting on hadronic structure model of the type here presented with increasing mass, and, therefore, increasing number of elementary constituents as per rules of Section 6.1C:

$$p(938) = \text{stable}, \quad (6.153a)$$

$$n(939) = (\hat{p}^+, \hat{e}^-)_{\text{hm}}, \quad (6.153b)$$

$$\Lambda(1115) = (\hat{p}^+, \hat{\pi}^-)_{\text{hm}}, \quad (6.153c)$$

$$\Sigma^+(1189) = (\hat{p}^+, \hat{\pi}^0)_{\text{hm}}, \quad (6.153d)$$

$$\Sigma^0(1192) = (\hat{n}, \hat{\pi}^0)_{\text{hm}}, \quad (6.153e)$$

$$\Sigma^-(1197) = (\hat{n}, \hat{\pi}^-)_{\text{hm}}, \quad (6.153f)$$

$$\Xi^0(1314) = (\hat{\Lambda}, \hat{\pi}^0)_{\text{hm}}, \quad (6.153g)$$

$$\Xi^-(1321) = (\hat{\Lambda}, \hat{\pi}^-)_{\text{hm}}, \quad (6.153h)$$

etc. It is an instructive exercise for the interested reader to prove that the hadronic structure model of the preceding sections permits an exact and invariant representation of all characteristics of the particle considered. It is equally instructive to prove that in each case we have the suppression of the atomic spectrum of energy down to one energy level only, that of the particles considered via the characteristic solution k_1 of increasing (positive) values bigger than 1 and k_2 more and more closer, but bigger than 1, as in values (6.62), thus ensuring the suppression of the atomic spectrum down to only one level.

In continuing the model to heavier baryons a number of additional rather complex events occur, such as pair creation *inside* hadrons. Quantitative studies

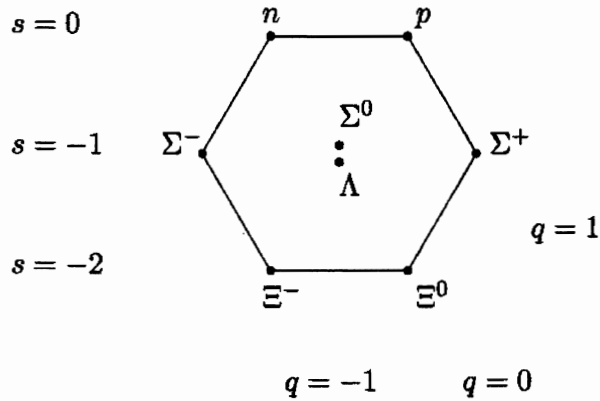

Figure 6.14. A view of the well known octet of baryons (from Wikipedia).

of these events require the prior development of *hadronic field theory* that has not been constructed to date. As such, these aspects are deferred to the specialized technical literature.

6.3.K Compatibility of baryon syntheses with the $SU(3)$ classification

The compatibility of the syntheses of baryons with $SU(3)$ classifications was achieved in the 1997 memoir in a way similar to that for mesons, Eq. (6.92), namely, with the following total isounit for the octet of barions

$$\widehat{I}_{\text{Tot, Oct}} = (\widehat{I}_p, \widehat{I}_n, \widehat{I}_\Lambda, \widehat{I}_{\Sigma^+}, \widehat{I}_{\Sigma^-}, \widehat{I}_{\Xi^+}, \widehat{I}_{\Xi^0}, \widehat{I}_{\Xi^-}), \quad (6.154)$$

and then the construction of the hypersymmetry $\widehat{SU}(3)$ characterized by the above hyperunit (see Chapter 2 and quoted literature and Section 4.5). The isomorphism between such a hypersymmetry and the conventional $SU(3)$ symmetry confirms the achievement of the desired equivalence under new intriguing degrees of freedom that can be used to resolve at least some of the remaining problems, such as the spin of baryons.

6.4 Laboratory Synthesis of Neutrons from a Hydrogen Gas

6.4.A Introduction

The laboratory synthesis of neutrons from a hydrogen gas according to Rutherford's conception is, by far, one of the most basic and important experiments of contemporary physics, with epistemological, scientific and environmental implications mostly beyond our comprehension at this time, hence, the need for its resolution one way or the other.

In fact, as stressed by Santilli in his works, the neutron is one of the biggest reservoirs of clean energy available to mankind since it decays spontaneously (when isolated) by emitting a highly energetic electron whose easy capture via a metal shield would produce a clean source of heat and electricity. Consequently, as we shall see in the next chapter, the neutron may admit mechanisms for its *stimulated decay*, with vast environmental implications. However, as stressed by Santilli in his works, the laboratory synthesis of the neutron outlined in this section is an evident pre-requisite for its possible stimulated decay outlined in the next chapter.

Additionally, as also stressed by Santilli, the neutron synthesis is the first and most fundamental fusion occurring in stars, since fusions synthesizing natural isotopes can only occur following the neutron synthesis. Therefore, no study of nuclear fusions can be truly exhaustive, or sufficiently deep, without prior experimental knowledge on the neutron synthesis.

Despite the above diversified fundamental relevance, the laboratory synthesis of neutrons from a hydrogen gas is incompatible with quantum mechanics. Consequently, the neutron synthesis has been generally opposed by academia for about half a century because its confirmation would terminate the current, widespread, preferred dominance by quantum mechanics for all conditions existing in the universe in favor of the covering hadronic mechanics.

The laboratory synthesis of the neutron from a hydrogen gas was first reached in the 1960s by the Italian priest-physicist of the University of Milan, Don Carlo Borghi and his colleagues, Don Carlo Giori and Antonio Dall'Olio. Being Italians, the experimentalists attempted to conduct first the test in Italy, but encountered extreme difficulties and were forced to conduct the experiment at the CEN Laboratories in Recife, Brazil. The results were presented in the communications [138], whose publication was rejected by various journals on grounds that the synthesis is not possible because contrary to quantum mechanics. Don Borghi continued to try for the rest of his days to dismiss his findings with independent re-runs, since experiments can solely be dismissed via counter-experiments and not via theoretical theologies, with no avail. No laboratory of his time could even consider the re-run of the test despite its evident fundamental character. Subsequently, Santilli managed to have one of the papers published in Russia as part of the proceedings [162]. The test is today known as *Don Borghi's experiment*. The above references will be quoted in this section as Don Borghi 1969 and 1993.

Due to its fundamental character, Santilli proposed for some thirty years the repetition of Dom Borghi's experiment to numerous nuclear physics laboratories around the world to receive flat rejections at best. With the passing of the years, Santilli and his associates constructed hadronic mechanics and achieved the exact representation of all characteristic of the neutron in its synthesis from the hydrogen atom as reported in Section 6.3. Hence, the laboratory verification



Figure 6.15. A view of the well known octet of baryons (from Wikipedia).

of the neutron synthesis became more and more necessary with the passing of time since the dismissals of the experiment via quantum mechanical arguments were no longer scientific.

After realizing the impossibility of testing the neutron synthesis in academic laboratories, Santilli had no other choice than that of doing the test himself at the laboratory of the *Institute for Basic Research* in Tarpon Springs, Florida, with the assistance of the IBR technicians J. Judy, G. West, M. Rodriguez, J. Alban and R. Jones.

The tests were conducted and repeated throughout the entire 1996 and concluded in early 1997 by confirming in full Don Borghi's results, although with a number of variations in its technical realization. The combined tests are today known as the *Don-Borghi-Santilli experiment*.

The paper presenting the measurements was rejected by journals of various physical societies on the same dismissals received by Don Borghi some forty years earlier, namely, that the claimed measurements are impossible because prohibited by quantum mechanics without any consideration of the complete solution then available via the covering hadronic mechanics. Santilli then published the paper in the *Hadronic Journal* [102] with the identification of the primary rejections in the main page. Santilli also provided the following website for detailed listing of scans and data [103]. This section is mainly derived from Kadeisvili's 2008 review [197].



Figure 6.16. A photo of Ruggero Maria Santilli by the Club Med, Martinique, April 2008.

6.4.B *Don Borghi experiment on the synthesis of neutrons from a hydrogen gas*

Don Borghi's 1969 experiment is truly simple and of easy duplication with very low costs. In essence, the experimentalists placed in the interior of a cylindrical metal chamber (called klystron) a hydrogen gas at a fraction of 1 bar pressure and kept partially ionized via an electric arc with about 500 V and 10 mA. Additionally, the gas was traversed by microwaves with 10^{-10} s frequency. Since protons and electrons are charged, they could not escape from the metal chamber, and remained trapped in its interior.

In the cylindrical exterior of the chamber, the experimentalists placed various materials suitable to be activated when exposed to a neutron flux (such as gold, silver and other substances). Following exposures of the order of days or weeks, the experimentalists reported nuclear transmutations due to a neutron count of up to 10^4 cps, apparently confirmed by β emissions evidently not present in the original material.

Note that Don Borghi's experiment makes no claim of direct detection of neutrons, and only claims the detection of clear nuclear transmutations that can only be caused by a neutron flux. Note also the dual presence of the electric arc plus the microwave. Note finally the credibility of the source, two of the experimentalists (Don Carlo Borghi and Don Camillo Giori) being Catholic priests.

Needless to say, Don Borghi experiment is in need of numerous independent reruns, either in its original form, or in one of several alternatives discussed in the next section. Nevertheless, Don Borghi experiment constitutes the first historical test on Rutherford's conception of the neutron, and it is remarkable, not only

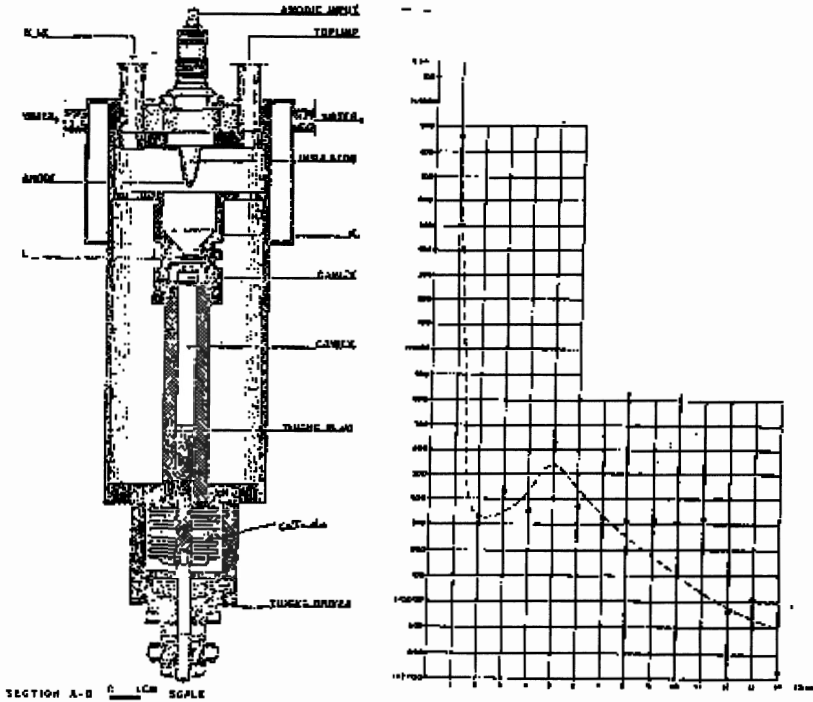

Figure 6.17. A view of Don Borghi's test equipment on the left and a typical activation curve on the right.

because of the claimed results, but also because of its simplicity and low cost, yet fundamental scientific implications.

6.4.C Santilli experiment on the synthesis of neutrons from a hydrogen gas

Santilli experiment reported in the 2007 paper consists of a cylindrical chamber (the klystron) filled up with a hydrogen gas and solely traverses by an electric arc without any microwave. The chamber was constructed via transparent PVC so as to assure via visual inspection the activation of the arc. This experimental set up was selected for the specific purpose experiment. The expectation was that, in the absence of any detection of a neutron flux via the sole use of the electric arc, the addition of high frequency microwaves was expected to be necessary. For pictures and further data see website [103].

Santilli conducted the radiation counts via:

- 1) A detector model PM1703GN manufactured by Polimaster, Inc., with sonic and vibration alarms as well as memory for printouts, with the photon channel

Element -	Net mass (gr)	Date --	Max net Activity ($\mu/10^6$)
Dy (oxide)	2,580	11/02/70 06/08/70	63 187
Nb (oxide)	2,125	26/02/70 04/08/70	61 47
Pr (oxide)	5,361	26/01/70 27/07/70	69 118
Sb (oxide)	2,688	15/02/70 24/07/70	51 97
In (metallic)	0,135	21/01/70	54
Ag (metallic)	2,130	12/02/70 16/06/70	51 17
Au (metallic)	0,960	23/02/70 10/07/70	10 27
Zn (metallic)	10,250	14/02/70	41

Figure 6.18. A view of Don Borghi's activation data.

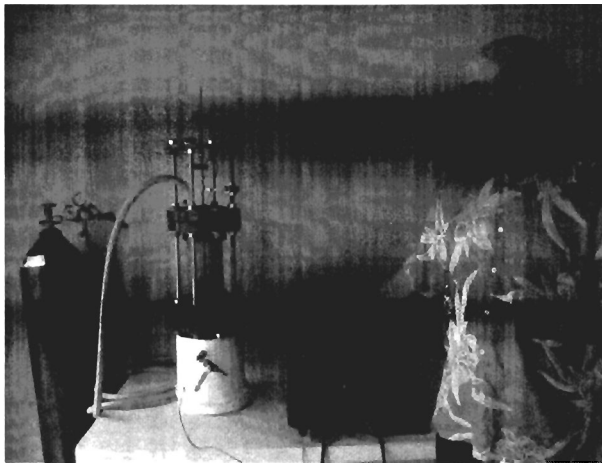

Figure 6.19. A view of Santilli's simple experimental set up showing the Miller DC Welder on the right, the PVC klystron in the center and the hydrogen pressure bottle on the left.

activated by CsI and the neutron channel activated by LiI. For reasons still under investigation (see below), the Li-activated neutron detectors resulted to be the most active and its use is necessary for any serious repetition of Santilli's tests.

2) A photon-neutron detector SAM 935 manufactured by Berkeley Nucleonics, Inc., with the photon channel activated by NaI and the neutron channel activated by He-3 also equipped with sonic alarm and memory for printouts of all counts. This detector was used to verify the counts from the preceding one.

3) A BF^3 activated neutron detector model 12-4 manufactured by Ludlum Measurements, Inc., without counts memory for printouts. This detector was used to verify the counts by the preceding two detectors.

Electric arcs were powered by welders manufactured by Miller Electric, Inc., including a Syncrowave 300, a Dynasty 200, and a Dynasty 700 capable of delivering an arc in DC or AC mode, the latter having frequencies variable from 20 to 400 Hz.

The following three different klystrons were manufactured, tested and used for the measurements (see the website for pictures):

Klystron I: A sealed cylindrical klystron of about 6" outside diameter (OD) and 12" height made of commercially available, transparent, PolyVinyl Chloride (PVC) housing along its symmetry axis a pair of tungsten electrodes of 0.250" OD and 1" length fastened to the tip of 0.250" OD copper rods protruding through seals out of the top and bottom of the klystron for electrical connections. The electrodes gap was controllable by sliding the top conducting rod through the seal of the flange.

The klystron cylindrical wall was selected to be transparent so as to allow a visual detection of the arc because, as shown below, in the absence of a true DC arc within a pure *hydrogen* gas, no detection is possible.

Following initiation of a real DC arc within the *hydrogen* filled klystron, there were hours and at times days of no detection at all by all counters. However, hours after shaking the klystron, detections occurred in a systematic and repetitive way.

The detection were triggered by a neutron-type particle, excluding contributions from photons (because often their count were null as shown by the scans), and they were definitely not due to vibrations. However, these detections were anomalous, that is, they did not appear to be due to a flux of actual neutrons originating from the klystron.

This anomaly is established by the repeated "delayed detections," that is, exposure of the detector to the klystron with no counts of any type, moving the detector away from the klystron (at times for miles), then seeing the detectors enter into off-scale vibrational and sonic alarms with zero photon counts.

The first case of this type occurred when Prof. Santilli exposed detector PM1703GN to the klystron following the arc, put the detector in his briefcase and went to a local Walgreen store for purchases, which store is located some

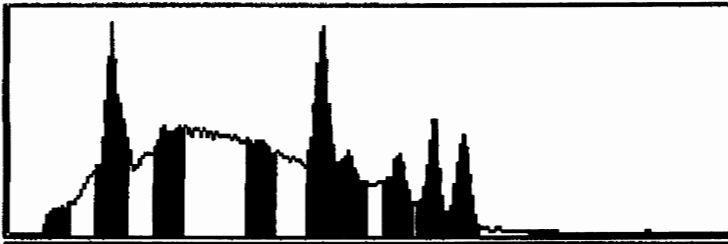

PEAKS FOUND

CHN	ENERGY (keV)	GROSS CPM	AMBIENT CPM	CONTINUUM CPM	NET CPM	UNC %
16	27.0	22122	972	16148	5002	± 4.25
37	97.9	132198	8006	65824	58368	± 0.89
56	194.8	106786	7284	92488	7014	± 6.70 U235s
87	424.4	90276	3602	85558	1116	± 38.5
110	646.5	128710	2760	68672	57278	± 0.89 Cs137
118	739.9	67746	2180	60060	5506	± 6.74
137	974.9	60834	2026	40820	17988	± 1.96 U238
149	1143.5	65446	1142	26070	38234	± 0.95 Co60
160	1305.5	52112	860	16148	35104	± 0.92 Co60
189	1819.3	4388	122	3498	768	± 12.3
210	2246.2	1542	20	1352	170	± 32.8
224	2543.3	1706	26	550	1130	± 5.19

2 OF 2 LIBRARY LINES FOR Co60 FOUND Correlation = 1.00

LINE	PEAK	INTENSITY	NET CPM
1173.2	1143.5	99.90	38234
1332.5	1305.5	99.98	35104

1 OF 1 LIBRARY LINES FOR Cs137 FOUND Correlation = 0.80

LINE	PEAK	INTENSITY	NET CPM
661.7	646.5	90.00	57278

1 OF 1 LIBRARY LINES FOR U235s FOUND Correlation = 0.80

LINE	PEAK	INTENSITY	NET CPM
185.7	194.8	57.00	7014

1 OF 1 LIBRARY LINES FOR U238 FOUND Correlation = 0.80

LINE	PEAK	INTENSITY	NET CPM
1001.0	974.9	2.00	17988

NUCLIDES NOT PRESENT:

2 OF 3 LIBRARY LINES FOR U233 FOUND	Correlation = 0.58
2 OF 3 LIBRARY LINES FOR Ra226 FOUND	Correlation = 0.05
0 OF 1 LIBRARY LINES FOR Am241 FOUND	Correlation = 0.00
0 OF 7 LIBRARY LINES FOR Eu152 FOUND	Correlation = 0.00
0 OF 0 LIBRARY LINES FOR Name FOUND	Correlation = 0.00

LINES NOT ASSOCIATED WITH ANY NUCLIDE:

Energy	Net CPM	Eff Corrected
27.0	5002.0	44976.7 C
97.9	58368.0	224471.0 C

Figure 6.20. One our of the large number of print-outs from the Berkeley Nucleonics detector Sam 935 following a neutron alarm in Santilli's 2007 tests.

15 m driving distance from the lab. To Prof. Santilli's great surprise and embarrassment, the detector in his briefcase entered into a maximal off-scale, sonic and vibrational, neutron alarm while he was in line for the payment of his bill. He had to leave his purchases and rush out of the store while the store personnel was calling security for control.

The 15 m "delayed self-activation" was reproducible with detector PM1703GN with the same time delay but in different locations although not with the other two who showed a different type of anomalous count (see [23] for brevity), thus establishing a *dependence of the neutron counts from the type of activation as well as on the casing material of the detector itself*.

Klystron II: A rectangular, transparent, PVC klystron 3" × 3" × 6" filled up with commercial grade hydrogen at atmospheric pressure and temperature traversed by a 2" long electric arc powered by a standard Whimshurst electrostatic generator.

This klystron was conceived for an *implosion* caused by combustion with atmospheric oxygen, thus explaining the small size of the klystron. This test was conducted only once because of instantaneous off-scale detection of neutrons by all detectors such to cause evacuation of the laboratory. Hence, this test was not repeated for safety.

Klystron III: A cylindrical metal klystron fabricated in schedule 80 carbon steel pipe with 12" OD, 0.5" wall thickness, 24" length and 3" thick end flanges capable of withstanding hydrogen pressure up to 500 psi with the internal arc between thoriated tungsten electrodes controlled by outside mechanisms.

This test was conceived for the conduction of the test at bigger hydrogen pressure compared to that of Klystron I. The test was conducted only once at 300 psi hydrogen pressure because of instantaneous, off-scale, neutron detections such to cause another evacuation of the laboratory.

It should be stressed that Santilli had no intention or interest in measuring the cps, since that would have been premature and, in any case, required much more sophisticated equipment. Hence, *the main purpose of Santilli's tests was to establish the production of neutron-type particles via a DC arc within a hydrogen gas*. No meaningful counts were detected with the above identified klystrons in using various gases other than hydrogen, although this should not exclude possible similar effects under sufficiently more powerful arcs. No neutron, photon or other radiation was measured from electric arcs submerged within liquids. Hence, the data herein reported appear to be specific for electric arcs within a hydrogen gas under the indicated conditions.

At the end of the tests, all detectors were returned to their manufacturers for control, and all detectors were certified as operating properly. The manufacturers then released the scans accumulated in the detector memories, some of which are reproduced in web site [103].

Alarm, neutron	9/1/2006/5:57:00 AM	99 Cps
Alarm, neutron	9/1/2006/5:58:00 AM	99 Cps
Alarm, neutron	9/1/2006/5:59:00 AM	99 Cps
Alarm, neutron	9/1/2006/6:01:00 AM	99 Cps
Alarm, neutron	9/1/2006/6:01:00 AM	99 Cps
Alarm, neutron	9/1/2006/6:01:00 AM	99 Cps
Alarm, neutron	9/1/2006/6:02:00 AM	99 Cps
Alarm, neutron	9/1/2006/6:02:00 AM	99 Cps
Alarm, neutron	9/1/2006/6:02:00 AM	99 Cps
Alarm, neutron	9/1/2006/6:03:00 AM	99 Cps
Alarm, neutron	9/1/2006/6:03:00 AM	99 Cps
Alarm, neutron	9/1/2006/6:03:00 AM	99 Cps
Alarm, neutron	9/1/2006/6:03:00 AM	99 Cps
Alarm, neutron	9/1/2006/6:04:00 AM	99 Cps
Alarm, neutron	9/1/2006/6:04:00 AM	99 Cps
Alarm, neutron	9/1/2006/6:04:00 AM	99 Cps
Alarm, neutron	9/1/2006/6:04:00 AM	99 Cps
Alarm, neutron	9/1/2006/6:05:00 AM	99 Cps
Alarm, neutron	9/1/2006/6:05:00 AM	99 Cps
Alarm, neutron	9/1/2006/6:05:00 AM	99 Cps
Alarm, neutron	9/1/2006/6:07:00 AM	99 Cps
Alarm, neutron	9/1/2006/6:08:00 AM	99 Cps
Alarm, neutron	9/1/2006/6:08:00 AM	99 Cps
Alarm, neutron	9/1/2006/6:09:00 AM	99 Cps
Alarm, neutron	9/1/2006/6:09:00 AM	99 Cps
Alarm, neutron	9/1/2006/6:09:00 AM	99 Cps
Alarm, neutron	9/1/2006/6:10:00 AM	99 Cps
Alarm, neutron	9/1/2006/6:10:00 AM	99 Cps
Alarm, neutron	9/1/2006/6:10:00 AM	99 Cps
Alarm, neutron	9/1/2006/6:11:00 AM	99 Cps
Alarm, neutron	9/1/2006/6:11:00 AM	99 Cps
Alarm, neutron	9/1/2006/6:14:00 AM	99 Cps
Alarm, neutron	9/1/2006/6:14:00 AM	99 Cps
Alarm, neutron	9/1/2006/6:15:00 AM	99 Cps
Alarm, neutron	9/1/2006/6:15:00 AM	99 Cps
Alarm, neutron	9/1/2006/6:15:00 AM	99 Cps
Alarm, neutron	9/1/2006/6:15:00 AM	99 Cps
Alarm, neutron	9/1/2006/6:15:00 AM	99 Cps
Alarm, neutron	9/1/2006/6:16:00 AM	99 Cps
Alarm, neutron	9/1/2006/6:16:00 AM	99 Cps
Alarm, neutron	9/1/2006/6:16:00 AM	99 Cps
Alarm, neutron	9/1/2006/6:16:00 AM	99 Cps
Alarm, neutron	9/1/2006/6:17:00 AM	99 Cps
Alarm, neutron	9/1/2006/6:17:00 AM	99 Cps
Alarm, neutron	9/1/2006/6:17:00 AM	99 Cps
Alarm, neutron	9/1/2006/6:17:00 AM	99 Cps

Figure 6.21. One out of a number of print-outs from the Polimaster detector PM1703GN following one of the sonic and vibrational alarms that caused evacuation of the laboratory in Santilli's tests.

In summary, Santilli states in his 2007 paper that an electric arc within a hydrogen gas at a few psi pressure and atmospheric temperature as above described for Klystron I produces "entities" that:

- 1) Are not hydrogen atoms (because in that case no nuclear transmutation would be conceivably possible);
- 2) Have dimensions of the order of 1 fm as for all hadrons (otherwise the detectors would show no counts);
- 3) Are neutral (otherwise they would not move through walls);
- 4) Are stable for hadron standards (more accurate data being grossly premature at this writing);
- 5) Remain initially confined within the arc chamber under steady conditions, to slowly exit, except for the case of production under implosion causing rapid propagation;
- 6) Are generally released hours following the tests, with anomalous counts lasting for weeks;
- 7) Are not neutrons due to the anomalous behavior of the detectors.

Santilli does not exclude that the "entities" produced in the tests with Klystrons II and III are indeed actual neutrons, due to the instantaneous as well as off-scale nature of the neutron alarms in clear absence of photon or vibrations.

Whatever their interpretation, we can state that *Santilli's 2007 experiment confirms Don Borghi's 1969 experiment because the latter test detected nuclear transmutations on various substances placed in the outside of the klystrons, which transmutations are necessary under the detected neutral particles in Santilli's tests.*

6.4.D The Don Borghi-Santilli neutroids

Santilli excludes that the entities produced in the tests with Klystron I are true neutrons for various reasons, such as:

- 1) The anomalous behavior of the detectors, for the case of the 15 m delay, self-activated detection indicates first the absorption of "entities" producing nuclear transmutations that, in turn release ordinary neutrons.
- 2) Stars can indeed produce the missing energy of 0.78 MeV for the neutron synthesis, but the environment inside Klystron I is not expected do the same, due to the very low density of the hydrogen gas, the low power of the DC welder and other factors.
- 3) The physical laws of hadronic mechanics do not allow the systematic synthesis of the neutron under the conditions of Klystron I because of the need of the *trigger*, namely (see Sections 6.2 and 6.3), an external action bringing the proton and the electron at 10^{-13} cm mutual distances, that is, permitting the transition from quantum to hadronic conditions. In fact, the tests with Klystrons II and III do admit such a trigger and have apparently produced neutrons.

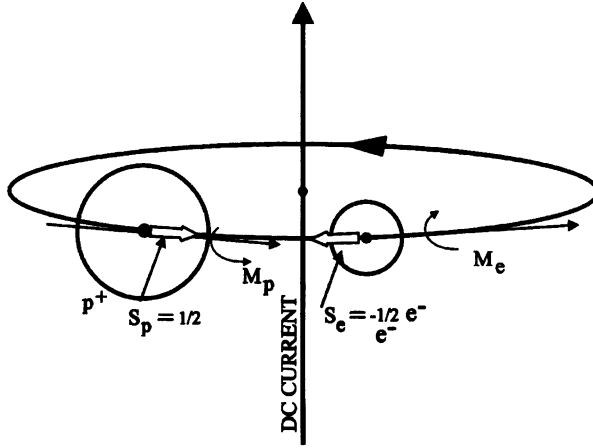
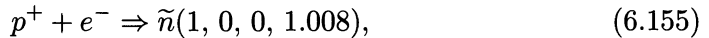

Figure 6.22. A schematic view of the geometry of a DC electric arc at subatomic distances in a ionized hydrogen gas. Note the alignment of polarized protons and electrons along the tangents to a magnetic line; a resulting axial coupling of protons and electrons under strongly attractive Coulomb forces due to opposite charges and magnetic polarities at short mutual distances; and the implausibility, under such a geometry, for protons and electrons to acquire 0.782 MeV relative kinetic energy “to fix things” in favor of preferred doctrines [102, 103].

In view of these and other reasons, Don Borghi submitted in his 1969 paper the hypothesis that the “entities” are neutron-type particles he called *neutroids*. Santilli adopted this hypothesis and presented the first technical characterization of neutroids with the symbol \tilde{n} and the characteristics in conventional; nuclear units $A = 1, Z = 0, J = 0$, amu = 0.008. Hence, Santilli assumed that in Klystron I he produced the following reaction precisely along Rutherford’s original conception



where: the value $J = 0$ avoids the spin anomaly in the neutron synthesis as indicated in Section 3; the rest energy of the neutroids is assumed as being that of the hydrogen atom because in atomic mass units

$$\begin{aligned} 1 \text{ amu} &= 931.49 \text{ MeV}, \\ m_p &= 938.27 \text{ MeV} = 1.0078 \text{ amu}, \\ m_e &= 0.511 \text{ MeV} = 0.0005 \text{ amu}, \end{aligned} \tag{6.156}$$

for which the hydrogen mass is given approximately by 1.008 amu; the $p - e$ binding energy of Coulomb nature is too small for the approximation considered, being of the order of 10^{-3} MeV.

The interpretation submitted by Santilli is that the geometry of the electric arc is quite conducive to processes causing the synthesis of neutron-type particles.

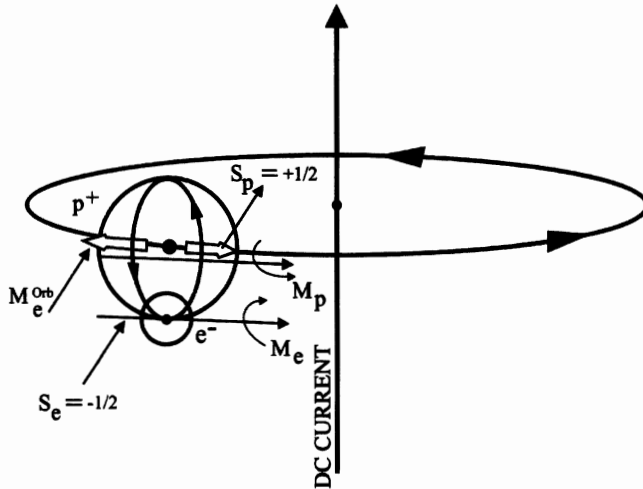

Figure 6.23. The inevitable bond of the polarized proton and electron of the preceding figure due to strongly attractive coulomb interactions for opposite charges and magnetic moments, presented by Santilli as a realization of Rutherford's "compressed hydrogen atom." Note that, at this stage, the particle has the charge and dimension of the neutron, but not its rest energy, spin and magnetic moment, thus being intermediate prior to the full synthesis of the neutron, the latter occurring under a sufficient external "trigger."

By recalling that the magnetic field created by an electric arc is directly proportional to the current and inversely proportional to the distance, in the conditions of Santilli's tests, protons and electrons are exposed to magnetic field with an intensity of the order of 10^9 Gauss when at atomic distances from the arc.

Under so powerful a magnetic field, the geometry of the electric arc first aligns protons and electrons with opposite polarities of their magnetic moments along the tangent to the local magnetic force. Subsequently, the same geometry is predicted to cause protons and electrons to collapse into a neutral, hadron-size particle due to the very strong Coulomb attractions at short distances of both, opposite charges and opposite magnetic polarities (see the figure).

The creation of neutroids is then due to additional reasons, such as the tendency of DC electric arc of compressing magnetically polarized particles toward the arc itself, resulting in the creation of the neutron-type neutroids.

The reader should be aware that, *despite the absence of the energy, spin and magnetic anomalies of the neutron, neutroids cannot exist for quantum mechanics and, consequently are assumed as being characterized by the covering hadronic mechanics as an intermediate state prior to the synthesis of the neutron.*

6.4.E Interpretation of Don Borghi and Santilli experiments

By remembering the etherino hypothesis of the preceding section, and by ignoring the neutrino hypothesis, Santilli assumes that the energy, spin and magnetic anomalies in the neutron synthesis are accounted for by the reaction

$$\tilde{n}(1, 0, 0, 1.008) + a \Rightarrow n(1, 0, 1/2, 1.008), \quad (6.157)$$

where “ a ” represents the etherino, namely, the transfer of the missing energy and other quantities either from the ether or from the interior of nuclei, as conditions allow.

In other words, once neutroids are absorbed by nuclei, ordinary neutrons can be produced via a variety of mechanisms, such as the supply of the missing energy, spin and magnetic moment by the nucleus itself, the origination of the missing characteristics from the ether, and other possibilities inessential for this section. In fact, the replacement of the etherino with the antineutrino, in the event desired by academic interests, would leave the content of this section unchanged

Paper 2007 then shows that assumption (6.157) is sufficient, alone, to represent “all” Don Borghi’s data. The open issue is whether the neutron synthesis occurs directly in the nuclei of the activated substances or in the walls of the klystron.

To study this alternative, Santilli assumes the usual symbol $N(A, Z, J, u)$ for ordinary nuclides as currently known, and the symbol $\tilde{N}(A, Z, J, \text{amu})$ for possible anomalous nuclides, namely, nuclides following the absorption of a nuclidoid not existing in available data, called *nuclidoids*.

Santilli also assume that the binding energy of a neutroid is similar to that of an ordinary nucleon (e.g., $BE = 0.0002$ amu for the deuteron), since neutroids are assumed to be converted into neutrons when inside nuclei, or to decompose into protons and electrons, thus recovering again the nucleon binding energy.

In this way, Santilli indicates the following possible nuclear reaction for one of the activated substances in Don Borghi’s tests

$$\text{Au}(197, 79, 3/2, 196.966) + \tilde{n}(1, 0, 0, 1.008) + a \Rightarrow \text{Au}(198, 79, 2, 197.972), \quad (6.158)$$

thus recovering conventional activation processes expected in Don Borghi’s activation.

By comparison, the application of the above assumption to the steel casing of Don Borghi klystron yields an unknown nuclidoid

$$\text{Fe}(57, 26, 1/2, 56.935) + \tilde{n}(1, 0, 0, 1.008) + a \Rightarrow \text{Fe}'(58, 26, 1, 57.941), \quad (6.159)$$

since the tabulated nuclide is $\text{Fe}(58, 26, 0, 57.933)$.

Needless to say, the anomalous nuclide $\text{Fe}'(58, 26, 1, 57.941)$ is expected to be highly unstable and to decay in a variety of possible modes, although they do

not appear to provide the source of neutrons necessary to represent Don Borghi data.

This excludes that the neutrons in Don Borghi experiment were synthesized in the walls of his klystron and confirms that the neutrons were synthesized by the activating substances themselves.

6.4.F Santilli's prediction of a new class of nuclides

Hypothesis (6.157) allows an interpretation of some of Santilli's detections, with the understanding that the anomalous behavior of the detectors, such as the delayed neutron counts, requires special studies and perhaps the existence of additional event not clearly manifested in Don Borghi's tests. To initiate the study, the 2007 paper considers the first possible reaction

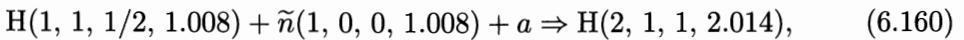

namely, we have the prediction that, under transmutation (6.157), the coupling of a neutroid to a proton plus an adequate trigger, creates the ordinary deuteron.

Next, Santilli considers the polycarbonate of Klystron I wall containing about 75% carbon, for which we have

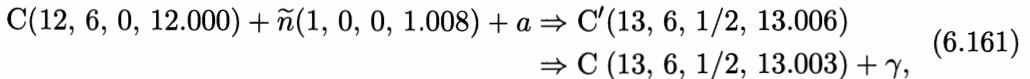

thus excluding the carbon of the polycarbonate being a source of the detected neutrons. Said polycarbonate contains about 18.88% oxygen for which we have the reaction yielding an unknown nuclidoid

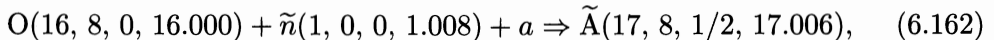

because the known nuclide is $\text{O}(17, 8, 5/2, 16.999)$. The latter reaction too is not expected to provide the neutron counts detected by Santilli. In conclusion, it does not appear that the detected neutrons are synthesized in the interior of the Klystron I or by its walls.

The above analysis leaves as the only residual possibility that *in Santilli tests, the neutrons are synthesized by the detectors themselves*. To study this possibility, Santilli considers the reaction for the He^3 -activated detector

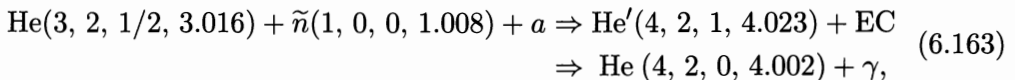

in which, as one can see, the detection of the neutroids is anomalous if any. Next, for the base of B-activated detectors we have the reactions

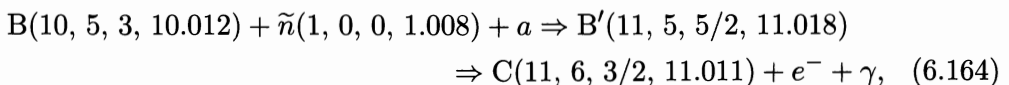

that do not appear to behave normally under a flux of neutroids. Finally, we have the reaction for the Li-activated detectors

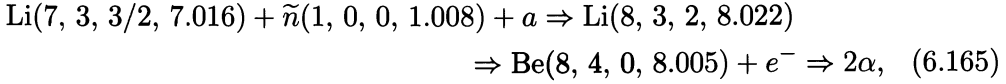

that do indeed behave in a way fully equivalent as to whether the detection refers to neutroids or neutrons.

However, in the absence of a proper trigger, the etherino is not expected to occur, particularly for light natural and stable nuclides. In this case, it is easy to see that the absorption of a neutroid by a nucleus generally yields a tabulated, thus highly unstable nucleus. For instance, in the absence of the etherino, reaction (6.165) reads

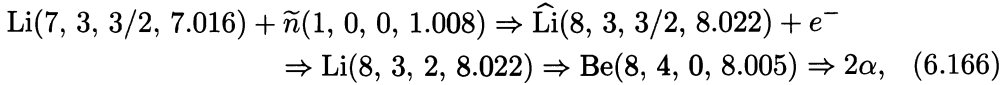

that yields again 2a easily detected buy the Li-activated detector. It is easy to verify that $\widehat{\text{Li}}(8, 3, 3/2, 8.022)$ is not tabulated, thus being a basically new nuclide that, since it has not been detected so far, it is expected to have a very short meanlife. Similar occurrences hold for the re-writing of the preceding reactions without the etherino.

Recall that the neutroid is expected to have strong interactions similar to those of ordinary neutrons, if nothing else, because of its proton content, thus being necessarily absorbed by nuclides when at mutual distances of the order of the strong interactions. Hence, Santilli introduces the following hypothesis (see also next chapter):

HYPOTHESIS 6.4G: The absorption of a neutroid by tabulated neuclides generally produces new highly unstable, untabulated nuclides called "nucleoids" according to the reaction

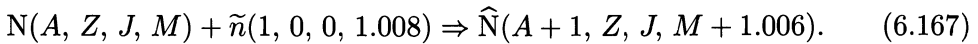

From the above reactions we can see a conceivable explanation of the reason the He³-activated detector resulted as being the least active of all 2007 tests. We can also see a plausible reason for the Li-activated detector as being the bests for Santilli's experiment, and that's the reason for mandating its use for any serious reruns.

The conclusion is, therefore, that *the neutrons detected in Don Borghi experiment were synthesized by the nuclei of the activated substances, while the neutrons of Santilli experiment were synthesized by the detectors themselves, either by activated substances, or by their casing, the latter expected as being the origin of the delayed detection.*

In closing, Santilli warns readers against superficial conclusions, one way or another, no matter how appealing they are, because of the possibility that *neutroids could be produced inside Klystron I in clusters much similar, although different than electron clusters*, in which case the absorption of neutroid clusters by ordinary nuclei is much more complex than the above analysis and cannot be treated here.

6.4.G Requirements for the re-run of Santilli's experiments

Needless to say, the tests of the neutron synthesis from a hydrogen gas is recommended for conduction under all possible conditions. Nevertheless, in the event these independent tests are used to claim either confirmation or dismissal of Santilli's results, the following conditions must be met to prevent lack of due process.

1) In Santilli's klystron, the electric discharge can be made under a short with no gap between the electrodes, in which case no "entities" are produced and the occurrence could be used to "disprove Santilli experiment." In fact, Santilli elected a transparent PVC klystron precisely to make sure he had an arc since, in case of a short without an arc, with at least a minimal gap of 2-3 mm for at least 4-5 seconds, no "re-run" of Santilli experiment can be scientifically claimed.

2) Santilli's experiment can be repeated with minimal power (say of 1 Kw), the use of a hydrogen gas with minimal pressure (say, a fraction of one psi), creating a real arc with a real gap within the hydrogen gas, resulting in no detection of any type for 2-3 days, thus claiming the "disproof of Santilli experiment." As indicated in the preceding sections, the production of the "entities" and the rapidity of their detection are proportional to the power, the pressure of the hydrogen gas and other factors.

3) Santilli experiment can be repeated with the klystron insulated from external influence such as noise, vibrations, etc., resulting in no detection for days, e.g. with the detector SAM 935, thus claiming the "disproof of Santilli experiment." As indicated in the preceding sections, at times Santilli had to shake the klystron with a rubber hammer, then wait for additional time to finally detect the "entities" outside the klystron, sometime occurring one or two weeks following the arc.

4) Santilli experiment can be easily dismissed with various neutron detectors none of which is Li-activated, then "fixing things" with a sufficiently low DC power and gas pressure, to end up with signals clearly not of neutron type. It has been indicated in the preceding sections that, for reasons unknown at this writing, Li-activation is, by far, the most sensitive to the "entities." Thus, the use of Li-activated detectors is mandatory for any scientific re-run of Santilli's experiment.

5) It is very easy to dismiss Santilli experiment via the mere use of the *Tables of Nuclides*. In fact, the transmuted nuclides caused by the absorption of a neutroid are not listed in said table and, consequently, they can be claimed not to exist. For the serious scholar we recall that the claim of production in Santilli experiment of true neutron, with consequential claims of producing conventional nuclides, is a direct admission of the continuous creation of matter in the universe for the reasons indicated in Section 6.3. But then, the only possibility of avoiding such extreme implications is to admit that the “entities” are not neutrons, and, consequently, the activated nuclei are not listed in the Table of Nuclides, that is, they are “new” in accordance with Hypothesis 6.4G.

As Santilli’s puts it: *It is generally believed in nuclear physics that all possible nuclides existing in nature, whether stable or unstable, are known. By remembering our extreme ignorance at this writing on the nuclear structure, e.g., our inability for a quantitative representation of nuclear forces, nuclear spins, nuclear magnetic moments, etc., the honest nuclear physicist must admit that our nuclear knowledge is at its infancy, and so much remains to be discovered by young minds of any age.*

6.5 Reduction of Nuclei to Protons and Electrons

6.5.A Introduction

As it is well known, in the same way as Rutherford conceived in 1920 the neutron as a bound state of a proton and an electron, nuclei were also considered in the early part of the 20th century as being bound states of protons and electrons.

The historical successes of quantum mechanics for the *atomic* structure forced its application also to the *nuclear* structure, resulting in the denial of Rutherford’s conception of the neutron, with consequential denial that nuclei are a bound state of protons and electrons.

Almost needless to say, quantum mechanics has permitted truly historical advances in nuclear physics with impressive verifications continuing to this day, such as the operation of nuclear power plants that are crucially dependent on the use of quantum mechanics. Nevertheless, as stated by Santilli, physics will never admit final theories because, no matter how exact a given theory may appear, its surpassing via broader theories for broader conditions is only a matter of time.

Also, on serious scientific grounds, a theory can be considered as being *exact* for given systems only when it represents *all* experimental data of the systems considered from first principles, that is, without the usual adulterations via the throwing into the equations of unknown parameters and arbitrary functions that are fitted from the data themselves, as customary in particle and nuclear physics.

On these serious grounds, quantum mechanics can indeed be considered as being *exactly valid for the hydrogen atom*, because it represented the totality

of the data in an exact way from first principles. By comparison, Santilli has identified in research for about half a century large evidence according to which *quantum mechanics can only be considered as being approximately valid for the nuclear structure because of its notorious inability of representing all nuclear data from first principles*, including inabilities for exact representations from first principles of nuclear spin, magnetic moments, meanlives and other data, not to mention gross insufficiencies for about one century on the understanding of the nuclear force.

Among the body of evidence accumulated by Santilli, the evidence particularly appealing is the impossibility for the Galilei and the Lorentz-Poincaré symmetries for being exactly valid for the nuclear structure because, in Santilli's words, *nuclei do not have nuclei* (see Figure 1.2). It is well known that the indicated spacetime symmetries are solely valid for *Keplerian systems*, that is, as recalled earlier, for a system of massive bodies in point-like approximation moving isolated in vacuum without collision around a heavier body known as the *Keplerian nucleus*.

The evident lack of exact validity of conventional spacetime symmetries for the nuclear structure has very deep implications. To begin, it confirms that both, nonrelativistic and relativistic quantum mechanics cannot possibly be exact for the nuclear structure in favor of covering more accurate formulations specifically built for the arena considered.

More deeply, the lack of exact validity of spacetime symmetries implies that the conception of nuclei as bound states of protons and electrons has no exact technical foundation. because these particles are technically characterized via unitary irreducible representations of the Galilei symmetry at the nonrelativistic level and the Lorentz-Poincaré symmetry at the relativistic level, thus leaving the way to broader, more accurate notions of nuclear constituents.

It is evident that Santilli's reduction of the neutron to a hadronic bound state of a proton and an electron directly implies the reduction of all nuclei and, therefore, all matter in the universe, to protons and electrons, for which very scope the construction of hadronic mechanics was proposed in memoir 1978B.

It should, however, be noted upfront that, on technical grounds, the constituents of nuclei are given by protons and electron in their form mutated by contact non-Hamiltonian, thus nonunitary interactions called *isoprotons* and *isoelectrons* and technically defined as isounitary irreducible representations of the Lorentz-Poincaré-Santilli isosymmetry.

Needless to say, the current conception of nuclei as bound states of protons and neutrons (nucleons) remains valid, but only as a first approximation of a much deeper physical reality.

In this section, we show that hadronic mechanics not only allows the reduction of nuclei to (iso) protons and (iso) electrons, but also achieves, for the first time

known to the authors, a numerically exact and invariant representation of various nuclear data beyond any dream of representation via quantum mechanics.

Needless to say, we cannot possibly review the entire formulation of nuclear physics according to hadronic mechanics. We shall then limit ourselves to illustrate the new nuclear vistas with a representation of all characteristics of the simplest nucleus, the deuteron, and leave the formulations of the remaining aspects of the new nuclear physics to interested colleagues.

6.5.B *Santilli's contributions in nuclear physics*

Santilli's main contributions of direct or indirect relevance for nuclear physics are the following:

- BASIC CONTRIBUTIONS: papers [43, 44, 99, 100, 109];
- LIE-ISOTOPIC CONTRIBUTIONS: [45, 53, 62, 65, 66, 68, 69, 73, 83, 97, 102, 107, 123];
- LIE-ADMISSIBLE CONTRIBUTIONS: [54, 120, 125, 131, 200];
- MONOGRAPHS: [1, 2, 9, 10, 12, 14, 17, 20–24, 122].

6.5.C *Review of basic nuclear contributions*

Recall that the quantum mechanical description of nuclear physics is centered on Heisenberg's equations characterizing the time evolution of an observable A in the following infinitesimal and finite form

$$i \frac{dA}{dt} = [A, H] = AH - HA, \quad A = A^\dagger, \quad H = H^\dagger, \quad (6.168a)$$

$$A(t) = \exp(Hti)A(0)\exp(-itH) = U(t)A(0)U(t)^\dagger, \quad (6.168b)$$

$$UU^\dagger = U^\dagger U = I, \quad (6.168c)$$

where: the brackets $[A, H]$ characterize a Lie algebra; the finite time evolution constitutes a Lie group characterized by a unitary transform on a Hilbert space, and the Hamiltonian H characterizes the total energy

$$H = \frac{p^2}{2m} + V(r). \quad (6.169)$$

Under these assumptions, the sole possible representation of the nuclear force is that via action-at-a-distance forces derivable from a potential, resulting in a sequence of failed attempts during the 20th century to achieve a final understanding of the nuclear force, with implausible extremes up to the use of a very large

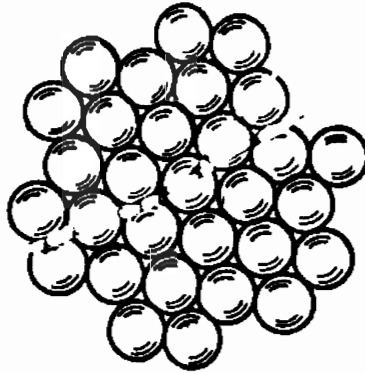

Figure 6.24. A view often used by Santilli to illustrate that nuclei are composed by extended constituents in contact with each other, thus prohibiting that the nuclear force is solely of potential type because the latter solely applies for action-at-a-distance forces among point-like particles. The need for a nonpotential component in the nuclear force motivated the birth and construction of hadronic mechanics.

number of potentials, as in Eq. (1.5), i.e.,

$$\begin{aligned}
 H = \frac{p^2}{2m} + V_1 + V_2 + V_3 + V_4 + V_5 + V_6 + V_7 + V_8 + V_9 + V_{10} + \\
 V_{11} + V_{12} + V_{13} + V_{14} + V_{15} + V_{16} + V_{17} + V_{18} + V_{19} + V_{20} + \quad (6.170) \\
 V_{21} + V_{22} + V_{23} + V_{24} + V_{25} + V_{26} + V_{27} + V_{28} + V_{29} + V_{30} + \\
 V_{31} + V_{32} + V_{33} + V_{34} + V_{35} + \dots
 \end{aligned}$$

Due to the manifest insufficiency of the above representation, Santilli main assumption is that, when part of a nuclear structure, nucleons are in conditions of partial mutual penetration and overlapping of their charge distributions as established by comparing nuclear volumes with the charge volumes of nucleons. Consequently, in addition to conventional (e.g., Coulomb) interactions derivable from a potential, nuclei must admit non-potential, thus non-Hamiltonian internal forces, generally called in the 20th century “nonconservative forces.”

Santilli proposed the construction of hadronic mechanics for the time invariant description of nuclear structures with both Hamiltonian and non-Hamiltonian internal forces. For this purpose, he first proposed in memoir [43] the Lie-isotopic generalization of Lie’s theory in its various branches (universal enveloping associative algebras, Lie algebras, and Lie groups) into a covering theory today known as *Santilli Lie-isotopic theory* based on the axiom-preserving product $[A, B] = ATB - BTA$, where T is a new Hermitean, positive-definite operator independent from H characterizing the inverse of the new unit $\hat{I} = 1/T > 0$ (see Chapters 2 and 3).

In memoir [43], Santilli also proposed the Lie-admissible broadening of his Lie-isotopic theory characterized by the product $(A, B) = ARB - BSA$, where R and S are also new operators independent from H , which product is Lie-admissible in the sense that the attached antisymmetry brackets $[A, B] = (A, B) - (B, A)$ is Lie-isotopic. This resulted in a yet broader theory today known as *Santilli Lie-admissible theory*.

Thanks to these necessary mathematical advances, in the subsequent memoir [44] of the same year, Santilli proposed *two* generalizations of quantum mechanics for nuclear physics, the first of Lie-isotopic character, based on the following lifting of Heisenberg equations today known as *Heisenberg-Santilli Lie-isotopic equations*

$$i \frac{dA}{dt} = [A, H] = ATH - HTA, \quad A = A^\dagger, \quad H = H^\dagger, \quad T = T^\dagger, \quad (6.171a)$$

$$A(t) = \exp(HTti)A(0) \exp(-itTH) = U'(t)A(0)U'(t)^\dagger, \quad (6.171b)$$

$$U'U'^\dagger \neq I. \quad (6.171c)$$

The above dynamical equations are at the foundation of the *Lie-isotopic branch of nuclear mechanics*. They imply that nuclei are represented via *two operators*, a conventional Hamiltonian representing physically valid potentials, plus the isotopic operator T representing contact non interactions not derivable from a potential,

$$H = \frac{p^2}{2m} + V(r), \quad (6.172a)$$

$$T = \exp[F(r) \int \psi^\dagger(r)\psi(r)d^3r], \quad (6.172b)$$

where $F(r)$ function is positive-definite and the T operator, here presented in a simple realization, is restricted to recover the identity at all distances greater than 10^{-13} cm, so as to recover quantum mechanics uniquely and unambiguously.

In the same memoir [44], Santilli proposed the broader Lie-admissible generalization of his Lie-isotopic equations characterized by equations today known as the *Heisenberg-Santilli Lie-admissible equations*

$$i \frac{dA}{dt} = (A, H) = ARH - HSA, \quad A = A^\dagger, \quad H = H^\dagger, \quad R = S^\dagger, \quad (6.173a)$$

$$A(t) = \exp(HSti)A(0) \exp(-itRH) = X(t)A(0)Y(t)^\dagger, \quad (6.173b)$$

$$XX^\dagger \neq I, \quad YY^\dagger \neq I, \quad (6.173c)$$

which are at the foundation of the broader *Lie-admissible branch of hadronic mechanics*, further broadened into the *hyperstructural branch* for biological structure

and the *isodual Lie-isotopic, isodual Lie-admissible and isodual hyperstructural branches* for antimatter hereon ignored.

In the latter case, nuclear processes are represented by *three operators*, the Hamiltonian H and the Lie-admissible operators R and S , e.g., of the type

$$H = \frac{p^2}{2m} + V(r), \quad (6.174a)$$

$$R = \exp[iF(r) \int \psi^\dagger(r)\psi(r)d^3r] = S^\dagger, \quad (6.174b)$$

where the latter expressions are restricted to the condition of admitting the isotopic formulation as a particular case for $R = S = T > 0$, and of recovering quantum mechanics identically and unambiguously at all distances bigger than 10^{-13} cm. The condition $R = S^\dagger$ originates from technical condition of consistency (see later on).

The reason for two, rather than one, generalization of quantum formalisms is the following. The Lie brackets $[A, B]$ and the Lie-Santilli bracket $[\widehat{A}, \widehat{B}]$ are invariant under anti-Hermiticity,

$$[A, B] = -[A, B]^\dagger, \quad [\widehat{A}, \widehat{B}] = -[\widehat{A}, \widehat{B}]^\dagger. \quad (6.175)$$

Consequently, *both, quantum mechanics and the Lie-isotopic branch of hadronic mechanics are invariant under time reversal*. Consequently, both mechanics are ideally suited to represent *isolated nuclei verifying all conventional conservation laws*, including that of the energy,

$$\begin{aligned} i \frac{dH}{dt} &= [H, H] = HH - HH = 0, \\ i \frac{d\widehat{H}}{dt} &= [\widehat{H}, \widehat{H}] = \widehat{H}\widehat{H} - \widehat{H}\widehat{H} = 0, \end{aligned} \quad (6.176)$$

the only novelty of the Lie-isotopic theory is the admission of internal nonpotential forces not possible for quantum mechanics.

More technically, Santilli proved that all conventional conservation laws of total quantities are preserved in the Lie-isotopic mechanics because the generators of basic spacetime symmetries, representing precisely such conservation laws, remain unchanged in the transition from the Lie to the Lie-isotopic symmetries.

The broader Lie-admissible formulation is necessary because, unlike the structure of stable nuclei, *nuclear reactions are generally irreversible over time*. Consequently, the representation of, say, a nuclear fusion

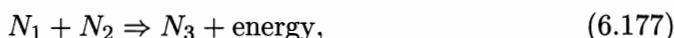

via both the Lie and the Lie-isotopic mechanics implies the existence of a finite probability of the existence of the time-reversal *spontaneous* disintegration of the

synthesized nucleus into the original nuclei

$$N_3 \Rightarrow N_1 + N_2, \quad (6.178)$$

in gross violation of energy conservation, causality and other basic laws. To avoid these catastrophic inconsistencies, Santilli conceived hadronic mechanics since its inception with the Lie-admissible branch because it is *irreversible over time* due to the property $R \neq S$, thus preventing no finite probability of inverse reaction (6.178). Rather than conservation law (6.176), the Lie-admissible branch characterizes the *time rate of variation of physical quantities*, such as that of the energy,

$$idH = (H, H) = HRH - HSH \neq 0. \quad (6.179)$$

The latter characterization was proposed in memoir [43] via advanced mathematics based on Lie-admissible transformation group we cannot possibly review here.

Following the achievement of the above formulations, it became known by Santilli and other scholars that nonunitary theories formulated via the mathematics of unitary theories (Hilbert spaces, conventional numerical fields, differential calculus, etc.) are afflicted by the so-called *Theorems of Catastrophic Mathematical and Physical Inconsistencies of Noncanonical and Nonunitary Theories* reviewed in details in Section 3.9, including the lack of preservation of the same numerical predictions under the same conditions at different times, lack of preservation of Hermiticity (thus, observability) over time, violation of causality, and other inconsistencies.

The resolution of these inconsistencies required decades of research, including the construction of two new mathematics, the first underlying the Lie-isotopic theories known as *isomathematics*, and the second underlying the lie-admissible theories known as *genomathematics*, reviewed in Chapter 2.

Following the construction of the needed new mathematics, and only thereafter, Santilli achieved the resolution of the inconsistency theorems for the Lie-isotopic case in memoir [99] of 1997 and for the Lie-admissible case in paper [100] of the same year. The formulation of hadronic mechanics, specifically, for nuclear physics was presented in memoir [109] of 1998.

In summary, to understand the treatment of nuclear physics via hadronic mechanics, one must first identify first whether the structure or process considered is reversible or not over time (invariant or not under time reversal). In the former case the Lie-isotopic formalism must be used with underlying isomathematics, and in the latter case the broader Lie-admissible formalism must be used with underlying genomathematics.

6.5.D *Review of Lie-isotopic nuclear contributions*

Prior to Santilli's studies, it was popularly believed that total conservation laws are solely verified by systems with conservative/potential internal forces, thus leading to the quantum treatment of nuclear structures since quantum mechanics can notoriously represent only potential forces. Santilli went to great lengths in disproving this belief, and established the existence of *closed-isolated non-Hamiltonian systems*, namely, systems with conservative-potential and nonconservative-nonpotential internal forces. In the latter systems, we merely have internal *exchanges*, in general, of all physical quantities in such a way that they cancel each other, since the system is assumed as being isolated, resulting in total conservation laws.

This important discovery, which is at the foundation of the Lie-isotopic representation of isolated stable nuclei, was studied in detail in the two monographs [1, 2] published by Springer-Verlag, Heidelberg, Germany. When visiting in 1991 Nobel Laureate Abdus Salam (in the the last months of his life) at the *International Center for Theoretical Physics* (ICTP) in Trieste, Italy, Santilli wrote paper [68] on closed non-Hamiltonian system (see also the review in Section 3.11D)

To illustrate the differences between closed Hamiltonian and non-Hamiltonian systems, Santilli has repeatedly compared the former to planetary systems, where all forces are clearly at a distance derivable from a potential, while, by contrast, non-Hamiltonian systems can be compared to the structure of Jupiter that, when isolated from the rest of the universe, clearly verifies all conventional total conservation laws, yet its interior structure has highly nonconservative internal effects visible via a telescope, such as tornado in the upper atmosphere with *locally varying angular momenta*. Santilli then assumes the planetary structure as a classical counterpart of the atomic structure, as customary, and the structure of Jupiter as a classical counterpart of the nuclear structure of hadrons, nuclei and stars.

During the same 1991 visit at the ICTP, Santilli also wrote paper [69] to illustrate that, rather unexpectedly, *contact internal forces among extended constituents, rather than complicating structure equations, generally allow exact analytic solutions*. For the two-body case of constituents with equal masses, the structure equation for Hamiltonian systems is rather complex with a number of elliptic orbits. When contact interactions are admitted forcing the constituents to remain at the same mutual distance, as it is the case for nuclear forces, the circle is the sole stable orbit, thus allowing a rather simple exact analytic solution. Similarly, three-body Hamiltonian systems do not admit analytic solutions, as well known. By comparison, when contact interactions are admitted, the system is turned into a restricted three-body with rather simple analytic solutions.

The next basic notion needed for an understanding of the new nuclear theory is that of *isoparticles* indicated in the preceding section. Unfortunately, this notion is very advanced since it requires a technical knowledge of Santilli Lie-isotopic

theory. Nevertheless, it is important to have at least a conceptual outline. As it is well known, action-at-a-distance interactions, such as electromagnetic interactions, generally alter the *kinematics characteristics* of particles, but they do not change the *intrinsic characteristics*, such as spin, charge, mass, etc. By comparison, as shown in the preceding sections 6.2 and 6.3, *contact non-Hamiltonian interactions generally alter all characteristics of particles, including mass, spin, charge, etc.* trivially, because the particle considered is under partial or total immersion within other particles, thus generally exchanging with the latter all possible physical characteristics.

Santilli has also dedicated particular care to the quantitative treatment of the notion of constituents of closed non-Hamiltonian systems called *isoparticles*, technically characterized by the notions of *mutation* or *isorenormalization*. A readable account is presented in papers [65, 73] also written at the ICPT in 1991. It should be indicated that the primary objective of the notion of isoparticle is to assure that, for example, an isoelectron in the core of a star *violates* the rotational symmetry as a necessary condition to prevent the nonscientific belief that an electron in the core of a star can orbit with a conserved angular momentum.

The implications of the notion of closed non-Hamiltonian systems with mutated constituents are truly far reaching. To begin, nucleons must be perfectly rigid for quantum mechanics, evidently as a necessary condition not to violate a pillar of the theory, the rotational symmetry. At any rate, quantum mechanics is known to be incompatible with the deformation theory. Santilli claims that such a rigid notion of nucleons is unrealistic because there exist no rigid bodies in nature, the sole debatable issue is the amount of deformation of nucleons under given external conditions. Hence, Santilli replaces the quantum notion of perfectly rigid nucleons with that of *isonucleons*, that is, isoprotons and isoneutrons that, as such, do admit deformations of their charge distribution since their shape verifies the covering rotational symmetry admitting indeed all possible deformations. In turn, such a deformability readily permits the first known exact numerical representation of nuclear magnetic moments from axiomatic first principles without ad hoc adulterations via arbitrary parameters and the like (see papers [65, 83] and Section 5.3).

Rather surprisingly, conventional quantum symmetries are not “destroyed,” but reconstructed as being exact at the covering Lie-isotopic level. Consider, for instance, the deformation of the perfect sphere on an Euclidean space with conventional metric $d = \text{Diag.}(1, 1, 1)$,

$$\begin{aligned} r^2 &= r^i \delta_{ij} r^j = x^2 + y^2 + z^2 \Rightarrow \\ \hat{r}^2 &= r^i \hat{T}_i^k \delta_{kj} r^j = x^2/n_1^2 + y^2/n_2^2 + z^2/n_3^2. \end{aligned} \quad (6.180)$$

Such a deformation causes the breaking of the rotational symmetry $SO(3)$ when treated via conventional mathematics with unit $I = \text{Diag.}(1, 1, 1)$. How-

ever, when the same deformation is treated via the new mathematics based on isounit

$$\hat{I} = \text{Diag.}(n_1^2, n_2^2, n_3^2), \quad (6.181)$$

the covering isorotational symmetry $\widehat{SO}(3)$ leaves invariant the ellipsoids while being isomorphic to the original symmetry $SO(3)$. This is due to the fact that the deformation of the semi axes, represented by the isotopic element \hat{T} , is entirely compensated by the *inverse* values of the isounit,

$$\hat{T} = \text{Diag.}(n_1^{-2}, n_2^{-2}, n_3^{-2}) \Rightarrow \hat{I} = \text{Diag.}(n_1^2, n_2^2, n_3^2), \quad (6.182)$$

resulting in the perfect sphere in isospace over isofields called the *isosphere*. Rather than being broken, the rotational symmetry is reconstructed as being exact, although under the proper mathematical formulation.

The reconstruction of the exact rotational symmetry also applies to all spacetime and other symmetries. In fact, the basic spacetime symmetries of the new nuclear structure, the *Galilei-Santilli isosymmetry* for nonrelativistic treatments and the *Lorentz-Poincaré-Santilli isosymmetry* for relativistic counterparts, are isomorphic to the original forms as a very condition to have consistent “isotopies” (see monographs [9, 10] and original contributions quoted therein). Therefore, rather than “destroying” the basic spacetime symmetries of the 20th century, Santilli has dramatically broadened their conditions of applicability.

To further illustrate the non triviality of these advances, we should note that statements such as “the $SU(2)$ nuclear isospin symmetry is broken by electromagnetic interactions” have been proved as being erroneous. In fact, Santilli has reconstructed in paper [107] the isotopic \widehat{SU} symmetry and proved that it is exactly valid under electromagnetic interactions while being isomorphic to the conventional $SU(2)$ symmetry. The mechanism is quite simple and essentially consists in embedding in the isounit all symmetry breaking terms.

The notion of isonucleons has additional very deep implications. One of them is the *inapplicability of Pauli's exclusion principle in the nuclear structure* pointed out by Santilli in the very title of memoir [44] and then studied in detail in various works, such as paper [45]. In essence, Santilli argues that Pauli's principle is definitely valid for fermions in a quantized energy level of an atomic structure. In the transition to a nuclear structure, we have the loss of quantized orbits to be replaced by shells, the general loss of the Fermionic character by the isonucleons and other feature that prohibit the very definition of Pauli's principle in the interior of a nucleus, let alone its verification. Note that Santilli stresses the *inapplicability* of Pauli's principle in nuclear physics and not its “violation.”

As an additional, far reaching implications, we should indicate that *the maximal speed of nuclear constituents is not limited by the speed of light in vacuum*. This occurrence was predicted by Santilli in paper [53] of 1982 on grounds that the maximal causal speed c of special relativity is based on the sole existence of

interactions admitting a potential energy. For the case of contact interactions the situation is dramatically different because contact interactions can accelerate particles without energy considerations, as it is the case of a balloon accelerated by wind in atmosphere. The absence of a potential energy then permits contact interactions of causal accelerations beyond the speed of light in vacuum.

Subsequently, Santilli provided great efforts for systematic theoretical studies of maximal causal speeds in the interior of non-Hamiltonian systems. In essence, the basic invariant of the Lorentz-Poincaré-Santilli isosymmetry is the *light isocone* here presented in two dimensions for simplicity

$$\widehat{x}^2 = z^2/n_3^2 - c^2t^2/n_4^2. \quad (6.183)$$

Consequently, the maximal causal speed is given by

$$V_{\max} = cn_3/n_4, \quad (6.184)$$

that, as such can be smaller, equal or bigger than c (see monographs [9, 10, 12, 14] for details).

Additionally, Santilli has conducted comprehensive experimental studies reported in [23] (see also the review in Chapter 5) according to which *the fit of experimental data from first axiomatic principles without ad hoc adulterations indicates that the maximal causal speed within hyperdense media, thus including in the interior of nuclei, is bigger than c .*

Papers [62, 66, 102, 123] have been reviewed in Section 6.3 and are at the foundation of the reduction of nuclei to protons and electrons. Paper [97] deals with the stimulated recycling of radioactive nuclear waste and will be considered in the next chapter.

6.5.E Review of Lie-admissible nuclear contributions

Dissipate processes in nuclear physics have been known since the inception of the theory. However, dissipation is incompatible with the axioms of quantum mechanics, since they describe conservation laws of Hermitean, thus observable quantities. To bypass this occurrence, a widespread approach to dissipativity in the 20th century nuclear physics has been the use of “imaginary potential” with Hamiltonians of the type

$$H = \frac{p^2}{2m} + iV(r). \quad (6.185)$$

Santilli pointed out in paper [54] of 1983 that under the above assumption, we have the following finite and infinitesimal time evolution of a Hermitean operator $A(t)$

$$A(t) = \exp(H^\dagger t)A(0)\exp(-itH) = W^\dagger(t)A(0)W(t), \quad (6.186a)$$

$$i\frac{dA}{dt} = [A, H, H^\dagger] = AH - H^\dagger A, \quad (6.186b)$$

$$WW^\dagger \neq I, \quad (6.186c)$$

namely, Heisenberg's unitary time evolution (6.168) characterized by the Lie brackets $[A, H]$ is turned into a *nonunitary time evolution characterized by the triple system* $[A, H, H^\dagger]$, namely, a structure which is incompatible with the axioms of quantum mechanics.

To begin, "imaginary potentials" have no known physical meaning of any type. Next, being nonunitary, time evolution (6.186) verifies the *Theorems of Catastrophic Inconsistencies* of Section 3.9. Finally, being non-Hermitean, the Hamiltonian is no longer observable, namely, time evolution (6.186) loses the observability for the very effect to be measured, the *nonconservation* of the energy.

To resolve these inconsistencies, paper [54] proposed the maintaining of the Hermiticity of the Hamiltonian as a necessary condition for its observability, and the use of the Lie-admissible time evolution (6.173) that assures indeed the dissipation of the observable energy, Eq. (6.179), by recovering in this way a fully consistent theory, although at the level of the covering hadronic mechanics.

In any case, the abandonment of quantum mechanics in favor of a covering mechanics for dissipative nuclear events is beyond any possible scientific doubt. The only open scientific issue is the appropriate covering theory. Santilli suggested the Lie-admissible branch of hadronic mechanics for the representation of dissipative nuclear events because of its "direct universality" for all possible non-conservations (representation of all possible systems in the frame of the observer), as well as because it is the only known formulation for nonconservative events achieving invariance over time, thus bypassing the Theorems of Catastrophic Inconsistencies.

The final invariant representation of all nonconservative processes, including dissipative nuclear events in particular, was reached by Santilli in the historical memoir [120] that is the apex of his research achievement since it includes as particular cases Lie-isotopic and quantum formulations. Particularly instructive for nuclear physicists is the study of the last section of memoir [120] with numerous examples of invariant representation of dissipative systems, as well as the "direct universality" in the representation of all possible non conservative forces not derivable from a potential with the operators R and S acting on a Hermitean but non-conserved Hamiltonian.

Papers [125, 131, 200] deal with a novel approach to nuclear fusion, thus being crucially dependent, for evident consistency, on the Lie-admissible formulation. Since these papers deal with a new form of clean energy, they will be reviewed in the next chapter.

6.5.F Reduction of the deuteron to two protons and one electron

6.5.F.A Foreword

We are now sufficiently equipped to review Santilli's structure model of the deuteron as a hadronic bound state of two protons and one electron verifying the laws and symmetries of hadronic mechanics. In fact, to prevent major misjudgments, its understanding requires the prior knowledge of the following aspects treated previously:

1) The deuteron is a *stable* light, natural isotope that, as such, is *reversible over time*, namely, its structure equation must be invariant under time reversal. Under the assumption of internal potential/Hamiltonian and contact/non-Hamiltonian forces, the sole known invariant treatment is that via Lie-isotopic formulations and basic dynamical equations (6.171);

2) Therefore, by using his structure model of the proton studied in Section 6.3, Santilli assumes the quantum mechanical structureless of the deuteron (hereon denoted "d")

$$d \approx (p^+, n)_{\text{qm}}, \quad (6.187)$$

as valid in first approximation, and reduces the deuteron to two protons and one electron according to the structure

$$d = (\hat{p}^+, \hat{e}^-, \hat{p}^+)_{\text{hm}}, \quad (6.188)$$

with the understanding that the constituents are isoparticles, namely, two *isoprotons* and one *isoelectron*, technically defined as isounitary irreducible representation of the *Galilei-Santilli isosymmetry* for nonrelativistic treatments and of the *Lorentz-Poincaré-Santilli isosymmetry* for relativistic formulations with consequential generally mutated *intrinsic* characteristics of mass, charge, spin, etc.;

3) Contrary to expectations, contact interactions generate a special version of restricted three body system that admits an exact analytic solution.

In this section we shall first review the several insufficiencies of quantum mechanics for a quantitative representation of very basic experiential data on the deuteron and then review their exact and invariant representation via Santilli isomechanics and underlying isomathematics.

6.5.F.B Insufficiencies of quantum mechanics for the deuteron structure

Despite the widespread acceptance of quantum mechanics throughout the 20th century as providing the final representation of nuclear structures, we begin our analysis with the review of the inability by quantum mechanics to represent the following basic data of the simplest possible nucleus, the deuteron, with embarrassing deviations for large nuclei such as the zirconium:

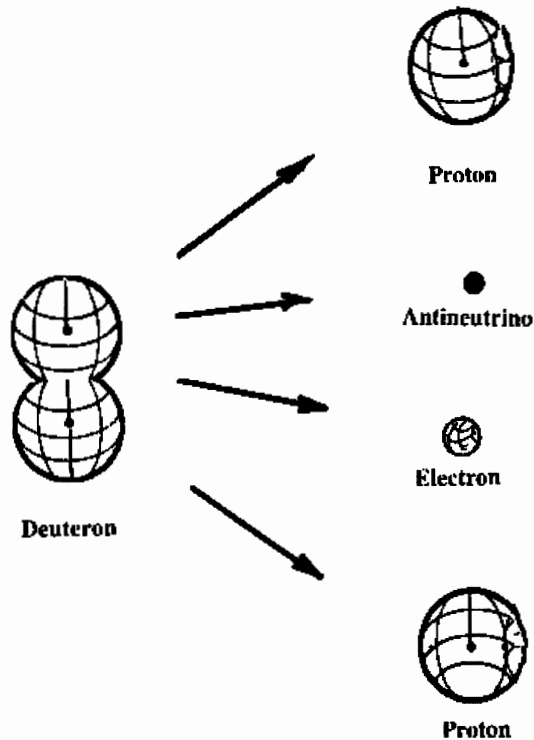

Figure 6.25. A reproduction of the drawing used by Santilli to illustrate the inability by quantum mechanics to represent the stability of the deuteron since the neutron is naturally unstable and, therefore, the deuteron should decay into two protons, an electron and the hypothetical antineutrino. No quantitative argument is known to the authors explaining the reason for the neutron to become stable when coupled to a proton. By comparison, Santilli's three body model of the deuteron represents its stability *ab initio*.

1) *Quantum mechanics has been unable to represent the stability of the deuteron.* This is evidently due to the natural instability of the deuteron. The unsolved problem is due to the absence in the technical literature of quantitative numerical proofs that, when bonded to a proton, the neutron cannot decay, as an evident condition for stability. Except for philosophical-political statements, the stability of the deuteron has been left fundamentally unexplained by quantum mechanics to this day (see Figure 6.25 for more details).

2) *Quantum mechanics has been unable to represent the spin 1 of the ground state of the deuteron.* The basic axioms of quantum mechanics require that the most stable bound state of two particles with the same spin is that with SPIN ZERO. No such state has been detected in the deuteron. Therefore, following one century of research, quantum mechanics has been unable to represent the spin 1

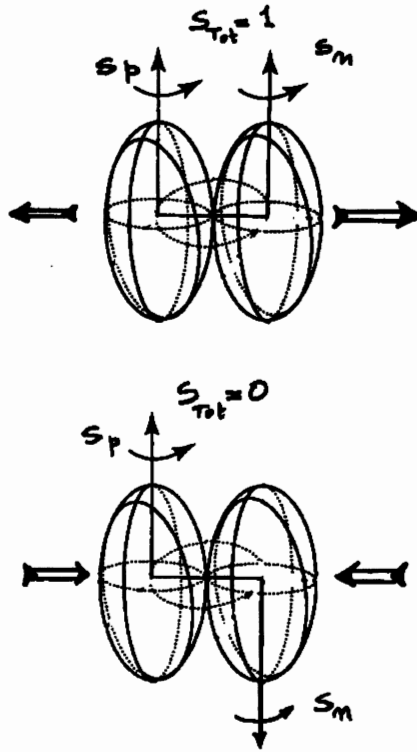

Figure 6.26. Reproduction of the original drawing used by Santilli to illustrate the impossibility of quantum mechanics to represent the spin 1 of the deuteron in a way compatible with its size. In fact, spin 1 can solely be achieved with a triplet coupling (top view), in which case no stable nucleus is conceivable due to very strong repulsive forces at the distance of nuclear forces. The only stable state is the singlet (bottom view), but in this case the total angular momentum is zero, in disagreement with experimental evidence.

of the ground state of the deuteron except, again, for political-nonscientific views (see Figure 6.26 for more details).

3) *Quantum mechanics has been unable to reach an exact representation of the magnetic moment of the deuteron.* After about one century of research, nonrelativistic quantum mechanics misses 0.022 Bohr units corresponding to 2.6% of the experimental value. Relativistic corrections reduce the error down to about 1% but under highly questionable theoretical assumptions, such as the use for ground state of a mixture of different energy levels that are assumed to exist without any emission or absorption of quanta as requested by quantum mechanics. Embarrassing deviations occur for the magnetic moments of heavier nuclei.

4) *Quantum mechanics has been unable to identify the physical origin of the attractive force binding together the proton and the neutron in the deuteron.* Since

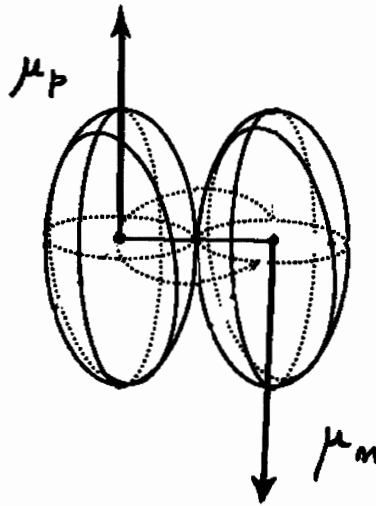

Figure 6.27. Reproduction of the figure used by Santilli to illustrate the impossibility by quantum mechanics to achieve an exact representation of the deuteron magnetic moment in a way compatible with the other characteristics such as total angular momentum, and charge radius.

the neutron is neutral, there is no known electrostatic origin of the attractive force needed for the existence of the deuteron. As a matter of fact, the only Coulomb force for the proton-neutron system is that of the magnetic moments, which force is REPULSIVE for the case of spin 1 with parallel spin. Therefore, a “strong” force was conjectured and its existence was subsequently proved to be true. Nevertheless, the physical origin of such strong force has remained unidentified following one century of research via quantum mechanics. Particularly mysterious remain the “exchange forces,” namely, forces originating from the exchange of protons and neutrons.

5) *Quantum mechanics has also been unable to treat the deuteron space parity in a way consistent with the rest of the theory.* The experimental value of the space parity of the deuteron is positive for the ground state, because the angular momentum L is null. However, in the dream of achieving compatibility of the deuteron phenomenology with quantum mechanics, nuclear physicists assume for the calculation of the magnetic moment that the ground state is a mixture of the lowest state with $L = 0$ with other states in which the angular momentum is not null, thus implying an embarrassing incompatibility of these calculations with the positive parity of the ground state.

In conclusion, after about one century of research, quantum mechanics has left unresolved fundamental problems even for the case of the smallest possible nucleus, the deuteron, with progressively increasing unresolved problems for heavier nuclei. Following these insufficiencies, any additional belief on the final character

of quantum mechanics in nuclear physics is a sheer political posture in disrespect of the societal need to search for a more adequate mechanics.

Not only quantum mechanics is not exactly valid in nuclear physics, but the very assumption of neutrons as nuclear constituents is approximately valid since neutrons are composite particles. Therefore, the main objective of this chapter is the identification of stable, massive physical constituents of nuclei and their theoretical treatment that admits in first approximation the proton-neutron model, while permitting deeper advances.

The replacement of protons and neutrons with the hypothetical quark is mathematically significant, with the clarification that, in Santilli's view, *quarks cannot be physical particles* because, as stresses several times in this presentation, *quarks are purely mathematical representations of a purely mathematical symmetry realized in a purely mathematical internal unitary space without any possible formulation in our spacetime (because of the O'Rafearthaigh's theorem).*

Consequently, *quark masses are purely mathematical parameters and cannot be physical inertial masses.* As also stressed several times, on true scientific grounds, inertial masses can only be defined as the eigenvalues of the second order Casimir invariant of the Lorentz-Poincaré symmetry. But this basic symmetry is notoriously inapplicable for the representation of quarks because of their particular features. Therefore, quark "masses" cannot have inertia.

Additionally, Santilli points out that the hypothetical orbits of the hypothetical quarks are excessively small to allow an exact representation of nuclear magnetic moments via their polarization. In fact, various attempts have been made in representing magnetic moments when reducing nuclei to quarks with the result of bigger deviations from experimental data than those for the proton-neutron structure. Similar increases of the problematic aspects occur for all other insufficiencies of quantum mechanics in nuclear physics. Consequently, the reduction of nuclei to quarks will be ignored hereon because of its excessive deviation from solid physical foundations as well as experimental data.

In conclusion, quarks can indeed be considered as replacements of protons and neutrons, with the understanding that *nuclei made up of quarks cannot have any weight*, since, according to Albert Einstein, gravity can solely be defined for bodies existing in our spacetime.

6.5.F.C Conception of the deuteron structure

Recall that the nuclear force solely applies up to the distance of 10^{-13} cm, which distance coincides with the charge radius of the proton as well as the electron wavepacket, and that the sole stable orbit for the two protons under contact strong interactions is the circle. The size of the deuteron then forces the charge distributions of two protons as essentially being in contact with each other (of course, in first nonrelativistic approximation). It then follows that the electron

is totally immersed within a proton, expectedly exchanging its penetration from one proton to the other.

Recall also that: the spin of the deuteron in its ground state is 1; the spin of the protons (assumed in first approximation as being un-mutated) is 1/2; the spin of the isoelectron is 1/2; and that the mutated angular momentum of the isoelectron is $-1/2$. These features suggested Santilli to assume the structure of the deuteron as being composed of two un-mutated protons with parallel spins rotating around the central isoelectron to allow the triplet coupling, and then the two coupled particles in line have an orbital motion around the isoelectron at the center, resulting in the first approximation in the following *hadronic structure model of the deuteron* [109] (see also monograph [17] and website [122])

$$d = (p_{\uparrow}^+, \hat{e}_{\downarrow}^-, p_{\uparrow}^+)_{\text{hm}}. \quad (6.189)$$

As we shall see, irrespective of the resolution of the objections against Rutherford's conception of the neutron presented in Section 6.3, a three-body structure provides the only known consistent representation of *all* characteristics of the deuteron, first achieved by R. M. Santilli in Ref. [109] of 1998.

6.5.F.D Representation of the stability of the deuteron

As indicated earlier, the lack of a quantitative representation of the stability of the deuteron when composed by the stable proton and the unstable neutron has been one of the fundamental problems left unsolved by quantum mechanics in about one century of research.

By comparison, protons and electrons are permanently stable particles. Therefore, structure model (6.189) resolves the problem of the stability of the deuteron in a simple, direct, and visible way. The deuteron has no unstable particle in its structure and, consequently it is stable due to the strength of the nuclear force.

In fact, as shown below, the Coulomb and contact attractive forces in pairwise singlet couplings proton-isoelectron are so "strong" to overcome Coulomb repulsion among the two protons and form a bound state that is permanently stable when isolated, as already established for the valence bond and Cooper pairs of identical electrons (Chapter 5).

6.5.F.E Representation of the deuteron size

Experimental data have established that the proton has the following values for the charge radius and diameter (size)

$$R_p = 0.8 \times 10^{-13} \text{ cm} = 0.8 \text{ fm}, \quad D_p = 1.6 \text{ fm}, \quad (6.190)$$

A value of the size of the deuteron that can be found in the literature is given by

$$D_d = 4.31 \text{ fm}. \quad (6.191)$$

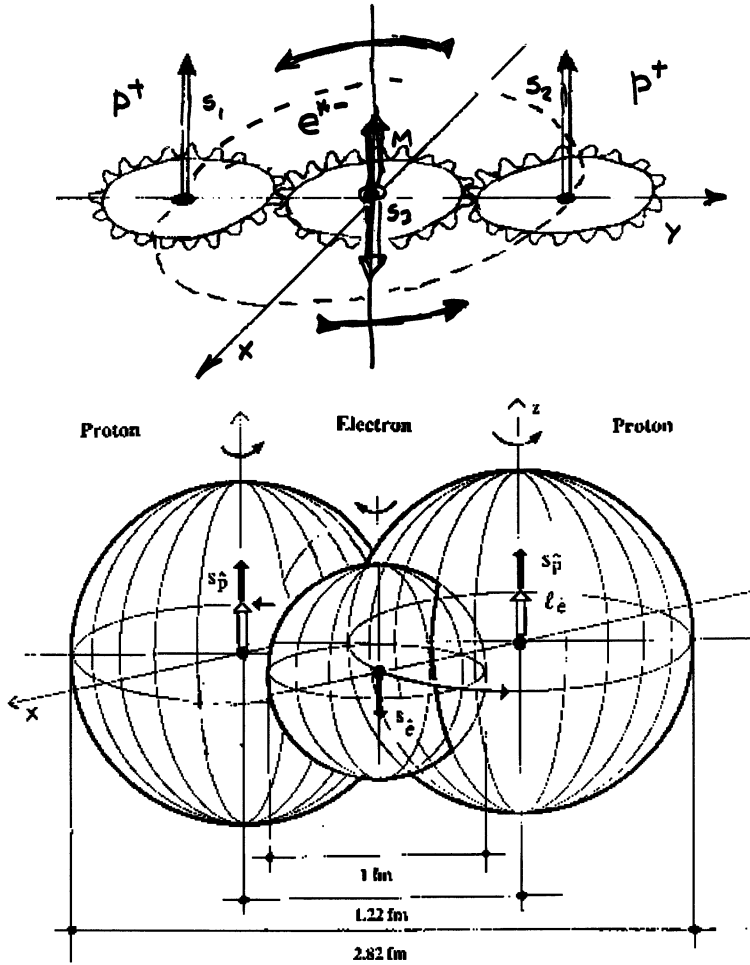

Figure 6.28. Reproduction of two original drawings used by Santilli to illustrate his conception of the structure of the deuteron as a restricted three body of two un-mutated protons (due to their weight) and one mutated electron. As reviewed in detail in the following sections, the top view uses the very effective “gear model” to avoid the highly repulsive triplet couplings, while the bottom view is the same as the top view, the particles being represented with overlapping spheres.

Structure model (6.189) does indeed fully represent the above data in accordance with Figure 6.28. In fact, the above data indicate that the charge radii of the two protons are separated by approximately 1.1 fm, namely, an amount that is fully sufficient, on one side, to allow the triplet alignment of the two protons as in the upper part of Figure 6.28 and, on the other side, to generate contact nonlocal effects from the penetration of the wave packet (here referred to the

square of the probability amplitude) of the central spinning electron within the two peripheral protons.

6.5.F.F Representation of the deuteron charge

At a first glance, model (6.189) trivially represents the deuteron positive charge $+e$. Nevertheless, its quantitative representation is not trivial at a deeper inspection. This is due to the fact that hadronic mechanics generally implies the mutation of *all* characteristics of particles, thus including the mutation \hat{Q} of conventional charges Q , and we shall write for the mutated charge of the deuteron constituents

$$\hat{Q}_{p_1} = ae, \quad \hat{Q}_e = be, \quad \hat{Q}_{p_2} = ce, \quad (6.192)$$

where a , b , c are positive-definite parameters, and e is the elementary charge. These mutations are necessary for consistency with other aspects, such as the reconstruction of the exact isospin symmetry in nuclear physics.

However, these mutations are only internal, under the condition of recovering the conventional total charge $+e$ for the system as a whole, as it is the case for closed non-Hamiltonian systems. Consequently, the charge mutations are subject to cancelation in such a way to yield the total charge $+e$, i.e.,

$$Q_d = (a + b + c)e = e, \quad a + b + c = 1. \quad (6.193)$$

Needless to say, the mutations of the charge is expected as being quite small in value since, namely as being a second order effect ignorable at a first approximation since the deuteron structure does not require the mutual penetration of the charge distribution of protons.

6.5.F.G Representation of the deuteron spin

As recalled earlier, quantum mechanics predicts that the most stable state between two particles with spin $1/2$ is the singlet, for which the total spin is zero, thus predicting that the ground state of the deuteron as a bound state of a proton and a neutron should have spin zero, contrary to the experimental value of spin 1.

When the deuteron is assumed as being a three-body bound state of two protons with an intermediate electron, hadronic mechanics achieves the exact and invariant representation of the spin 1 of model (6.189) in a way similar to that of the neutron (Section 6.3). It is easy to see that the electron is trapped inside one of the two protons, thus being constrained to have an angular momentum equal to the spin of the proton itself. In this case, with reference to Figure 6.28, the total angular momentum of the isoelectron is null. By recalling that the ground state has null angular momentum, *the total angular momentum of the deuteron is given by the sum of the spin $1/2$ of the two isoprotons.*

Recall that fractional angular momenta are prohibited for quantum mechanics (namely, when angular momenta are defined on a conventional Hilbert space over the conventional field of complex numbers), because they violate the crucial condition of unitarity, with consequential violation of causality, probability laws, and other basic physical axioms.

For hadronic mechanics, the isotopic lifting \widehat{S} and \widehat{L} of the spin S and angular momentum L of the electron when immersed within a hyperdense hadronic medium are characterized by

$$\widehat{S}^2 T|\widehat{s}\rangle = (PS)(PS + 1)|\widehat{s}\rangle, \quad (6.194a)$$

$$\widehat{S}_3 T|\widehat{s}\rangle = \pm(PS)|\widehat{s}\rangle, \quad (6.194b)$$

$$\widehat{L}^2 T|\widehat{a}\rangle = (QL)(QL + 1)|\widehat{a}\rangle, \quad (6.194c)$$

$$\widehat{Q}_3 T|\widehat{a}\rangle = \pm(QL)|\widehat{a}\rangle, \quad (6.194d)$$

$$S = 1/2, L = 0, 1, 2, \dots, \quad (6.194e)$$

where P and Q are arbitrary (non-null) positive parameters.

Recall that Santilli introduced the above isotopy of $SU(2)$ -spin to prevent the believe of the perpetual motion that is inherent when the applicability of quantum mechanics is extended in the core of a star. In fact, quantum mechanics predicts that an electron moves in the core of a star with an angular momentum that is conserved in exactly the same manner as when the same electron orbits around proton in vacuum, thus exiting the boundaries of science, since an electron in the core of a star can only have a *locally varying* angular momentum and spin as represented by Eqs. (6.194).

For the case of the isoelectron in the deuteron, we have the *constraint* that the orbital angular momentum must be equal but opposite to that of the spin,

$$\widehat{S} = P(1/2) = -\widehat{L} = Q, \quad Q = -P/2, \quad \widehat{J}_{\text{tot}} = 0. \quad (6.195)$$

The exact and invariant representation of the spin 1 of the ground state of the deuteron then follows according to the rule

$$J_d = S_{p_1} + S_{p_2} = 1. \quad (6.196)$$

An elaboration of the mechanisms of representing arbitrary angular momenta may be helpful to the non-initiated reader. Suppose that the quantum mechanical angular momentum operator L has expectation value 1,

$$\langle a|L|a\rangle = 1, \quad (6.197)$$

Under isotopic lifting the above expression easily acquires the value 1/2 for $T = 1/2, \widehat{L} = 2$

$$\langle \widehat{a}|T\widehat{L}T|\widehat{a}\rangle = 1/2. \quad (6.198)$$

However, in this case the isounit is given by $\hat{I} = 1/T = 2$. Therefore, when the isoeigenvalue of the angular momentum is properly represented as an isonumber (an ordinary number multiplied by the isounit), one recovers the original value 1,

$$\langle \hat{a} | T \hat{L} T | \hat{a} \rangle \hat{I} = 1, \quad (6.199)$$

thus recovering causality and other laws.

Note that there is no violation of Pauli's exclusion principle in this case since that principle only applies to "identical" particles and does not apply to protons and neutrons, as well known (more explicitly, one of the two protons of Eq. (6.189) is in actuality the neutron since it has embedded in its interior the isoelectron).

6.5.F.H Representation of the deuteron magnetic moment

Recall the first exact and invariant representation of the magnetic moment of the deuteron was reached in Section 5.3 under the conventional proton-neutron interpretation while the proton and the neutron are isoparticles.

We review here Santilli's second, exact and invariant representation of the magnetic moment of the deuteron according to model (6.189). Let us recall the following experimental values of magnetic moments for the deuteron and its constituents

$$\mu_d = \frac{0.8754eh}{2\pi M_p c}, \quad \mu_p = \frac{2.792782eh}{4\pi M_p c}; \quad (6.200a)$$

$$\mu_e = \frac{eh}{4\pi M_e c} = \frac{eh}{4\pi M_p c} \frac{M_p}{M_e} = \frac{938.272}{0.511} \frac{eh}{4\pi M_p c} = 1.836 \times 10^3 \frac{eh}{4\pi M_p c}. \quad (6.200b)$$

Recall also that the deuteron is in its ground state with null angular momentum in which case there is no orbital contribution to the total magnetic moment from the two protons. By keeping in mind the structure of the deuteron as per Figure 6.28, the *exact and invariant representation of the total magnetic moment of the deuteron* is then given by

$$\mu_d = 2\mu_p + \mu_{\text{tot},e} = 2 \times 2.792 \frac{eh}{4\pi M_p c} + \mu_{\text{tot},e} = 0.8754 \frac{eh}{2\pi M_p c}, \quad (6.201a)$$

$$\begin{aligned} \mu_{\text{tot},e} &= 0.8754 \frac{eh}{4\pi M_p c} - 5.584 \frac{eh}{4\pi M_p c} = -4.709 \frac{eh}{4\pi M_p c} = \\ &- 4.709 \frac{eh}{4\pi M_e c} \frac{M_e}{M_p} = -8.621 \times 10^{-4} \frac{eh}{4\pi M_e c} = \mu_{e,\text{orb}} - \mu_{\hat{e},\text{spin}}, \end{aligned} \quad (6.201b)$$

namely, the missing contribution is provided by the total magnetic moment of the isoelectron. In particular, the latter numerical value is given by the difference between the orbital and the intrinsic magnetic moment that is very small (per electron's standard) since the total angular momentum of the isoelectron is indeed small.

Also note the correct value of the sign because the isoelectron has the orbital motion in the direction of the proton spin. But the charge is changed in sign. Therefore, the direction of the orbital magnetic moment of the isoelectron is opposite that of the proton, as represented in Eqs. (6.189). Note finally that the small value of the total magnetic moment of the isoelectron for the case of the deuteron is close to the corresponding value for the neutron, Eqs. (6.132).

6.5.F.I Representation of the deuteron force

As indicated earlier, the assumption that the deuteron is a bound state of a proton and a neutron permits no identification of the physical origin of the nuclear force. Quantum mechanics merely provides numerous mathematical descriptions of the attractive force via a plethora of potentials, although none of them admits a clear physical explanation of the *strong attraction* between protons and neutrons.

Santilli's primary objective in generalizing quantum mechanics for nuclear physics is the truncation of this century old failed process of keep adding new and new potentials in the nuclear force, and search instead for fundamentally different notions and representations, a task for which hadronic mechanics has no known equals.

In fact, model (6.189) permits a clear resolution of this additional insufficiency of quantum mechanics via the precise identification of *two* types of nuclear forces, the first derivable from a Coulomb potential and the second of contact type represented with the isounit.

The constituents in the configuration of Figure 6.28 have short range pair-wise opposite signs of charges and magnetic moments with long range identical signs of charges and magnetic moments. This configuration implies the following *net attractive Coulomb force in the deuteron*

$$V_d = -\frac{e^2}{0.6 \text{ fm}} + \frac{e^2}{1.2 \text{ fm}} - \frac{\mu_p \mu_e}{0.6 \text{ fm}} + \frac{\mu_p \mu_e}{1.2 \text{ fm}}. \quad (6.202)$$

In addition, the constituents admit an attractive force not derivable from a potential due to the deep penetration of their wavepackets in singlet pair-wise couplings, which force is the same as that of: the two identical electrons in the Cooper and valence pairs (Part III); the structure of mesons (Part IV); the structure of the neutron (Part V); and can be represented via the isounit in now familiar notations

$$\hat{I} = \exp[F(r) \int \psi_{\uparrow}^{\dagger}(r) \psi_{\downarrow} d^3(r)]. \quad (6.203)$$

As the reader may recall from Sections 6.2 and 6.3, the projection of the above force in our spacetime (that with trivial unit 1) characterizes a strongly attractive Hulthen potential, that behaves at short distances like the Coulomb potential, by therefore "absorbing" the latter and resulting in a single, dominating, attractive Hulthen well with great simplification of the calculations.

Besides the above potential and contact force, no additional nuclear force is needed for an exact and invariant representation of the remaining characteristics of the deuteron (such as binding and total energies), as shown below.

For instance, the mysterious “exchange force potentials” (in which protons and neutrons interchange themselves) become unnecessary and, if used, misleading because the underlying physical effect is of purely *contact type*, thus having no meaningful potential at all. If a potential is granted, as done throughout the 20th century, it is like describing the resistive force of a spaceship during re-entry in our atmosphere with a potential, thus exiting the boundary of science. It is easy to prove that the isoelectron cannot solely be restricted to exist within one of the two protons, because there exists a 50% isoprobability of moving from the interior of one proton to that of the other proton. Therefore, the *proton-neutron exchange* is confirmed by model (6.189) and so is the attractive character of the related force.

Similarly, “noncentral forces” are un-necessary in model (6.189) because they become a particular case of the broader nonlocal forces extended over the volume of wave-overlappings. The important point is that, again, noncentral forces generally do not have a potential energy in classical mechanics and the idea that they could instead acquire a potential energy in nuclear mechanics is not plausible unless proved beyond doubt.

A similar fate holds for the various other mysterious forces adopted in nuclear physics during the 20th century. They all become un-necessary for the treatment via hadronic mechanics unless their action-at-a-distance, potential character is established on rigorous grounds. An illustration is that of “velocity-dependent potentials.” They are known as being particular cases of contact nonlocal forces because the latter are approximated via power series in the velocities and other variables. The occurrence illustrates again the remarkable power of the isounit for unifying a considerable variety of forces assumed as being of potential type in the 20-th century, with a consequential dramatic reduction of the number of meaningful nuclear forces.

6.5.F.J Representation of the deuteron total energy

As it is well known, the binding energy of the deuteron is given by

$$E_d = -2.26 \text{ MeV.} \quad (6.204)$$

Recall from the main lines of hadronic mechanics that the binding energy is mainly characterized by forces derivable from a potential since the contact forces due to mutual wave-overlapping of wave packets have no potential energy. Hence, the binding energy of the deuteron is due to the potential component of the deuteron binding force, Eq. (6.202), as the reader can verify by using known values of charges and magnetic moments for the two electron-proton pairs of the deuteron and their mutual distances as identified earlier.

Hadronic mechanics also permits the exact and invariant representation of the total energy of the deuteron, that, as such, becomes another verification of model (6.189). Recall the following conversion of one atomic mass unit to MeV

$$1 \text{ amu} = 941.49432 \text{ MeV}, \quad (6.205)$$

and the known values

$$\begin{aligned} M_p &= \frac{938.256 \text{ MeV}}{c^2} = 1.00727663 \text{ amu}, \\ M_e &= \frac{0.511 \text{ MeV}}{c^2} = 5.48597 \times 10^{-4} \text{ amu}. \end{aligned} \quad (6.206)$$

The mass of a nucleus with A nucleons and Z protons without the peripheral atomic electrons is characterized by

$$M_{\text{nucleus}} = M_{\text{amu}} - Z \times M_e + 15.73 \times Z^{-3} \times 10^{-6} \text{ MeV}, \quad (6.207)$$

that yields for the deuteron

$$M_d = 2.0135 \text{ amu} = 1875.563 \text{ MeV}. \quad (6.208)$$

The iso-Schrödinger equation for model (6.189) can be reduced to that of the neutron, Eq. (6.103), under the assumption that the isoelectron spends 50% of the time within one proton and 50% within the other, thus reducing model (6.189) in first approximation to a two-body system of two identical particles with un-isorenormalized mass $\widehat{M} = 937.782 \text{ MeV}$, the main differences being given by different numerical values for the energy, meanlife and charge radius.

Santilli reaches in this way the *structure equation of the deuteron in a first two-body nonrelativistic approximation*

$$d = (\widehat{p}_\uparrow, \widehat{p}_\uparrow)_{\text{hm}}, \quad (6.209a)$$

$$\left(-\frac{\hbar^2}{2M_{\widehat{p}}} \Delta - V \times \frac{\exp(-r/R)}{1 - \exp(-r/R)} \right) |\widehat{p}\rangle = E|\widehat{p}\rangle, \quad (6.209b)$$

$$E_d = 2E_{\widehat{p}} - |E| = 1875 \text{ MeV}, \quad (6.209c)$$

$$\tau_d^{-1} = 2\lambda^2 |\widehat{e}(0)|^2 \alpha E_{\widehat{e}} / \hbar = \infty, \quad (6.209d)$$

$$R_d = 4.32 \times 10^{-13} \text{ cm}. \quad (6.209e)$$

It is easy to see that the above equations admit a consistent solution reducible to the algebraic expressions as for the case of Rutherford-Santilli neutron

$$k_2 = 1, \quad k_1 = 2.5. \quad (6.210)$$

It should be indicated that, in the above model, the deuteron binding energy is null,

$$E = -V \frac{(k_2 - 1)^2}{4k_2} \approx 0, \quad (6.211)$$

because all potential contributions have been included in the structure of \hat{p} and, for the binding of the two \hat{p} , all potential forces have been “absorbed” by the nonlocal forces and k_2 has now reached the limit value of 1 (while being close to but bigger than 1).

A more accurate description can be obtained via the *restricted three-body configuration* of Figure 6.28 that, as such, also admits an exact solution. The model can be constructed via a nonunitary transform of the conventional restricted three-body Schrödinger equation for two protons with parallel spin 1/2 and one isoelectron with null total angular momentum as per Figure 6.28 with conventional Hamiltonian $H = T + V_{\text{Coul}}$, where V_{Coul} is expression (6.202). The nonunitary transforms then produces an additional strong Hulthen potential that can, again, “absorb” the Coulomb potential resulting in a solvable equation. This more accurate approach is left to the interested researcher.

6.5.F.K Representation of the deuteron electric dipole moment and parity

The electric dipole moment of the deuteron is identically null. Its representation via hadronic mechanics follows from the fact that isotopies cannot alter null values.

The positive parity of the deuteron is trivially represented by hadronic mechanics via the expression

$$\text{Isoparity} = (-1)^{\hat{L}}, \quad (6.212)$$

and the value for the unperturbed deuteron in its ground state $\hat{L} = L = 0$.

By comparison, the reader should be aware of another misrepresentation existing in the nuclear literature consisting of the fact that, on one hand, the parity of the deuteron is positive ($L = 0$), while on the other hand, in order to attempt a recombination of deuteron magnetic moments and spin, the unperturbed deuteron is assumed as being a mixture of different levels, some of which have non-null values of L , thus implying the impossibility of a positive parity.

In summary, Santilli has shown that the isotopic branch of nonrelativistic hadronic mechanics permits the exact and invariant representation of “all” the characteristics of the deuteron composed by two isoprotons and one isoelectrons, while jointly resolving all quantum insufficiencies identified above.

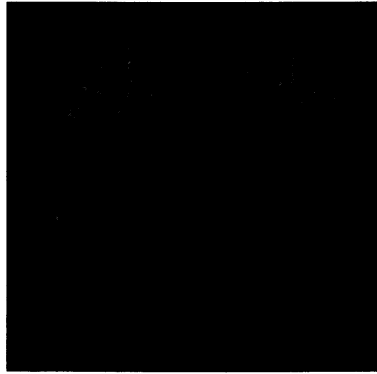

Figure 6.29. We would like to close this chapter by indicating Santilli's additional astrophysical contribution given by the fact that the so-called "neutron stars" are in reality an extremely high density and high temperature fluid composed by the original constituents of the star, protons and electrons, in conditions of deep mutual penetration under the laws of hadronic mechanics.

6.5.G *Reduction of matter to proton and electrons*

It is evident that, following the reduction of the neutron to a proton and an electron and the reduction of the deuteron to two protons and one electron, Santilli has indeed achieved the important reduction of all matter to protons and electrons, since the reduction of the remaining nuclei to protons and electron is consequential, e.g., as a hadronic bound state of two mutated deuterons.

6.5.H *Reduction of neutron stars to protons and electrons*

We have pointed out earlier various astrophysical implications off Santilli's research, such as:

- 1) The initiation of *antimatter astrophysics* with the first known possibility of identifying whether a far away star or galaxy is made up of matter or of antimatter (Section 3.7);
- 2) The absence of universe expansion, big bang, dark matter and dark energy expected from Santilli isoredshift (Section 5.5);
- 3) The new conception of stars as a portal for continuous creation via the transfer of energy from the universal substratum to out world as needed for the synthesis of the neutron (Section 6.2) and other astrophysical contributions.

We would like to close this chapter by indicating Santilli's additional astrophysical contribution given by the fact that the so-called "neutron stars" are in reality an extremely high density and high temperature fluid composed by the original constituents of the star, protons and electrons, in conditions of deep mutual penetration under the laws of hadronic mechanics.

Chapter 7

NEW CLEAN ENERGIES FOR A NEW ERA

7.1 Introduction

Let us initiate the closing chapter of this book with the following statement released by Santilli:

Owing to increasingly alarming climatic events, whose violence is expected to increase in a progressively accelerating manner, the biggest need for the very survival of our society is the identification and industrial development of new clean energies. Consequently, the biggest duty of our scientific institutions, for which I see no comparison, is the discovery new, environmentally friendly energies.

A main problem is that, on one side, scientific institutions generally operate under a self-imposed mandate to conduct only the research which is in strict compliance with 20th century theories while, on the other side, all energies that could be conceived or are otherwise permitted by Einstein special relativity, quantum mechanics and quantum chemistry were fully identified by the middle of the past century and they all resulted as being environmentally unfriendly, either because of excessive production of green house gases, or because of the release of harmful radiation and/or radioactive nuclear waste nobody knows where or how to dispose of.

The dichotomy between our scientific institutions and the environmental need for mankind is rendered un reassuring, with a consequential variety of issues pertaining to scientific ethics and accountability, by the fact that Einstein special relativity, quantum mechanics and quantum chemistry are strictly reversible over time, while all energy releasing processes are strictly irreversible. Hence the belief that the former preferred doctrines are exactly valid for the latter processes is amoral, asocial and ascientific, since the only possible debatable issue is the selection of the appropriate generalizations-coverings.

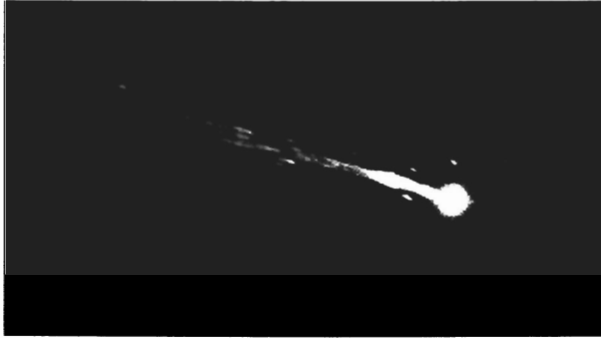

Figure 7.1. A NASA picture of a spaceship during reentry in our atmosphere often used by Santilli to illustrate visual experimental evidence often ignored by academia, the irreversibility of interior dynamical events, the impossibility of their serious reduction to elementary particles in nice reversible conditions, and the consequential need to achieve, in due time, an irreversible covering of the entire 20th century sciences.

When faced with the above evidence, often studiously ignored, a traditional objection that is voiced with rapidly propagating support is that the irreversibility of our physical reality is only “apparent” (sic) because, so the claim states, when the irreversible macroscopic event is reduced to its elementary particles constituents, the irreversibility “disappears” (sic) and one recovers conventional theories.

However, I proved decades ago the following property that has been also propagated in the physics community but equally ignored, thus without disproof:

THEOREM: A macroscopic process that is irreversible over time cannot be consistently decomposed into a finite number of elementary particles all reversible over time and, vice versa, a finite number of elementary particles all reversible over time cannot yield a macroscopic irreversible process under the correspondence or any other principle.

The implication of the above theorem, whose proof has been confirmed by first year graduate students, are rather deep. It implies that, rather than “disappearing” to allow the applicability of a preferred theory, the origin of irreversibility rests at the most ultimate level of nature, that of elementary particles. As an example, the irreversibility of a spaceship during reentry in our atmosphere originates from nonlinear, nonlocal an nonpotential interactions between the electron orbitals of peripheral atoms of the spaceship and the corresponding orbitals of atmospheric atoms.

In view of the above scenario, the only serious hope for mankind to resolve our alarming environmental problems is to build, test and establish irreversible generalizations-coverings of Einstein special relativity, quantum mechanics and quantum chemistry specifically conceived for the conception, testing and industrial development of new clean energies.

To my best knowledge, the Lie-isotopic and Lie-admissible relativity, and related branches of hadronic mechanics and chemistry, are the only broadening of conventional doctrines verifying the conditions: 1) Directly universality for the representation of interior dynamical systems of extended particles within physical media; 2) Invariance under their own time evolutions so as to avoid catastrophic inconsistencies; and 3) Unique and unambiguous admission of conventional doctrines as simple particular cases whenever exterior conditions of point particles in vacuum are recovered. In particular, the new covering disciplines and their novel underlying mathematics have achieved operational maturity, as proved by experimental verifications in all quantitative sciences, as well as the prediction and industrial development of new clean energies.

In this chapter, we review the new clean energies permitted by Santilli Lie-isotopic and Lie-admissible classical and operational formulations in atomic physics, nuclear physics and particle physics. A main objective of the presentation is to show that the new energies studied in this chapter are prohibited by 20th century doctrines and, consequently, they are crucially dependent on “deviations” from orthodox theories.

The main book underlying this chapter is given by the work [17] (hereon referred to as the 1999 monograph). The second main reference of this chapter is Santilli’s subsequent work [18] (hereon referred to as the 2001 monograph). A comprehensive treatment of the new energies is presented in Santilli’s five volumes [20–24] (hereon denoted 2008 monographs). Additional papers will be quoted later on when needed. An in depth knowledge of hadronic mechanics and chemistry as outlined in Chapters 3 and 4, respectively, is necessary for a technical understanding of this chapter, let alone to prevent the illusion of serious criticisms.

7.2 New hadronic energies of atomic type

7.2.A Limitations of 20th century doctrines for energy releasing processes

In this section, we review a new form of energy based on a new form of novel combustion, today known as *Santilli magnecular combustion*, permitted by hadronic mechanics and chemistry whose very existence is crucially dependent on *deviations* from 20th century chemistry. For technical details one may consult Santilli 2001 and 2008 monographs.

One of the most serious constrain in the evolution of science is the belief, rather widespread in the scientific community, that Einstein special relativity, quantum mechanics and quantum chemistry apply for all conceivable conditions existing in the universe, expectedly until the end of time. Unreassuringly such a belief is the very reason for the lack of resolution until now of our alarming environmental

problems since said belief restrains the conception, let alone development of new clean energies.

In the preceding chapters, we have reviewed rather vast evidence on the limitations of 20th century theories in all quantitative sciences and their resolution by Santilli Lie-isotopic and/or Lie-admissible formulations. In preparation for the content of this section, we recall that Maxwell equations, the Lorentz-Poincaré symmetry and Einstein special relativity describe quite well an *electric arc in vacuum* (see Figure 4.16). However, when dealing with corresponding interior conditions, such as an *electric arc in water*, Santilli has identified a number of basic insufficiencies all with damaging environmental implications.

To begin, Santilli indicates that there is no need to conduct measurements for admitting the inapplicability of 20th century doctrines for a submerged electric arc because of the evident and well known facts that the very basic notions of electric resistance, entropy and other thermodynamical laws crucial for interior dynamical problems are irreconcilably incompatible with Einstein special relativity, quantum mechanics and quantum chemistry. It is evident that, without the capability of defining resistance, entropy and thermodynamical laws *ab initio* from primitive axioms, any description of submerged electric arc with 20th century theories is flawed at best, or denoting theological preferences.

In addition to the above basic evidence, Santilli has indeed conducted comprehensive measurements and established the following deviations of experiential evidence on submerged electric arcs from Einstein special relativity, quantum mechanics and quantum, chemistry that are so large to prevent even the usual use of unknown functions thrown into the equations “to adjust things” details (see the website www.magnegas.com):

1) Quantum mechanics and chemistry predict that a DC arc between carbon electrodes submerged within distilled water produces a combustible gas composed by about 65% H_2 , 32% CO and 2% to 3% H_2O , CO_2 and other molecules. But CO is combustible in air producing CO_2 . Hence, quantum mechanics and chemistry predict that the combustion exhaust of said gas should contain about 40% CO_2 . Numerous measurements have established that the combustion exhaust of said gas contains about 4% to 6% of CO_2 thus establishing close to a *ten-fold deviation* of the predictions of quantum mechanics and chemistry from measured data. Since CO_2 is the gas responsible for increasingly alarming climactic events, the study of combustible gases produced by submerged electric arcs cannot be solely done with 20th century doctrines without raising issues pertaining to scientific ethics and accountability.

2) Quantum mechanics and chemistry predict that the combustion exhaust of the above gas in an exact stoichiometric ratio with oxygen does not contain appreciable percentage of O_2 , said exhaust being composed by H_2O , CO_2 and small impurities. On the contrary, various measurements have established that

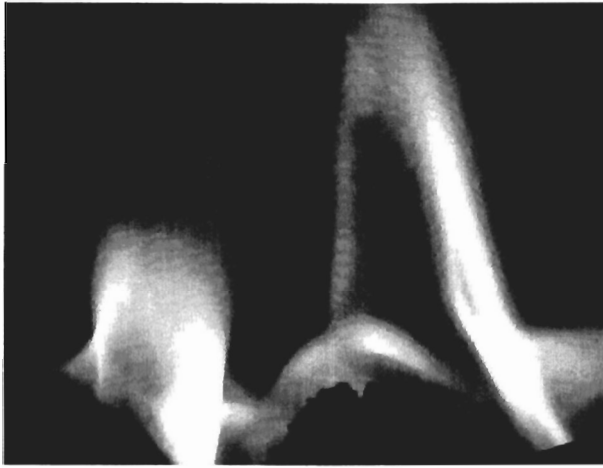

Figure 7.2. In Santilli's view, tens of thousand of years have passed since mankind discovered fire, but we are still far from achieving a quantitative representation of combustion at the primitive level of valence electron bonds for numerous reasons, such as: the irreversible character of combustion compared to the reversible character of quantum mechanics and chemistry; the absence in 20th century chemistry of a quantitative identification of the attractive force in a valence bond; and other insufficiencies discussed in Chapter 4.

the indicated combustion exhaust contains up to 14% breathable oxygen, thus establishing another large deviation of 20th century doctrines from reality. Since oxygen is the very essence of life, the insistence in the study of the indicated gas via 20th century doctrines is clearly not warranted for the solution of environmental problems.

3) By remembering that H_2 contains about 300 BTU/scf and CO about 89 BTU/scf, according to quantum mechanics and chemistry the above combustible gas contains about 240 BTU/scf. However, clear experimental evidence establishes that said gas cuts 5" metal plates faster than acetylene that contains 2,400 BTU/scf, thus establishing yet another large deviation of 20th century theories from experimental evidence.

The above occurrences prove beyond scientific doubt that a quantitative understanding of the *deviations* from Einstein special relativity, quantum mechanics and quantum chemistry has primary relevance for the solution of our environmental problems.

7.2.B *Conventional molecular combustion*

Twenty century chemistry has identified several types of *combustion* easily identifiable in the related vast literature generally classified for their *macroscopic — visual* behavior, such as complete, incomplete, rapid, explosive and

other combustion, although without any structural study whatsoever at the atomic or molecular level achieving a numerical representation of all evidence, beginning with the irreversibility of the processes.

Santilli points out that, at the *microscopic — structural level*, all types of combustion are reducible to dissociation of valence bonds among atomic constituents of the original fuel and the creation of new valence bonds among the atomic constituents of the combustion exhaust. As a representative case, this is the case for the combustion of hydrogen in oxygen



Similarly, we have the complete combustion of methane in air



the incomplete combustion of propane in air

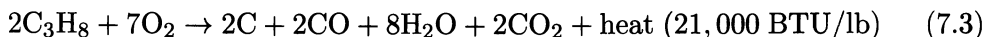

and numerous other combustions.

In all cases, quantum chemistry has identified rather precise *rules and data*, combustion by combustion. However, according to Santilli, we are essentially dealing with “nomenclatures” in the sense that the descriptions are mainly conceptual-mnemonic, since they lack a quantitative representation of the rather complex processes occurring at the level of individual valence couplings.

After all, as reviewed in Chapter 4, the very notion of valence coupling lacks a quantitative identification of the *attractive force* between identical valence electrons, by always keeping in mind that *identical electrons repel each other according to quantum mechanics*, and certainly they do not attract each other to form any bond.

7.2.C Santilli's magnecular combustion

A main insufficiency of the quantum chemical notion of combustion is the following. In Santilli's view, for combustion (7.1) to occur, the $\text{H}_2\text{O} = \text{H} - \text{O} - \text{H}$ molecule contains only *one* O-atom and the two H-atoms are widely separated as clearly shown in Figure 4.7. Therefore, he argues that *combustion of hydrogen and oxygen releases much more energy than 57 Kcal/mole we measure, the biggest portion of the produced energy being used by nature to separate the $\text{H}_2 = \text{H} - \text{H}$ and the $\text{O}_2 = \text{O} - \text{O}$ molecules. In this view, the measured amount of 57 Kcal/mole is merely the small final energy residue.*

In fact, we have the following well known separation energies

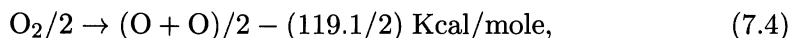

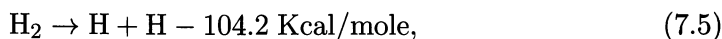

Consequently, the belief that the combustion of hydrogen and oxygen solely produce 57 Kcal/mole violates the sacred principle of conservation of the energy, since separations (7.4) and (7.5) would then occur by academic fiat and not by following physical or chemical laws.

Santilli argues that, as a necessary condition to verify the principle of conservation of the energy, the combustion of hydrogen and oxygen must produce about 221 Kcal/mole so as to provide the energy necessary for the separation of H_2 and O_2 plus the 57.5 Kcal/mole residue, according to the *combustion law for molecular hydrogen and oxygen*

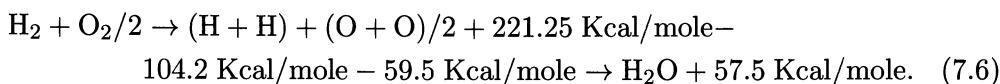

Once the real combustion law has been understood, it is easy to see the environmental and industrial importance of *Santilli's fuels with magneuclear structure* (Section 4.4) because they contain individual atoms under a bond weaker than the valence bond. Therefore, *magneuclear fuels yield an energy output greater than that of molecular fuels with the same atomic structure*. To clarify these new notion, Santilli has introduced the following definitions:

MOLECULAR COMBUSTION: *is that for fuels whose atoms are entirely under a molecular bonds, such as hydrogen, methane, propane, etc.*

MAGNECULAR COMBUSTION: *is that for fuels whose atoms are at least in part, under a magneuclear bond, and the rest under a molecular bond, such as MagneGas, HHO, MagneHydrogen and other fuels.*

The superior energy output of magneuclear fuels with respect to molecular fuels with the same atomic composition is beyond scientific doubt. Consider, for instance, MagneGas produced by an arc between graphite electrodes submerged within distilled water that contains about 66% H-atoms, 16% O-atoms and 16% C-atoms, plus impurities here inessential. Recall that H_2 contains about 300 BTU/scf, while CO contains about 89 BTU/scf. Consequently, the fuel with conventional chemical composition of 66% H_2 and 33% CO contains

$$(0.7 \times 300 + 0.3 \times 89) \text{ BTU/scf} = 236 \text{ BTU/scf}. \quad (7.7)$$

It is beyond doubt that such a molecular fuel cannot possibly cut metal faster than acetylene, as any skeptic is requested to verify experimentally, as Santilli did, prior to venturing personal theologies, by actually testing in metal cutting the indicated molecular and magneuclear fuels with the same atomic constituents.

By comparison, as indicated earlier, magnegas cuts metal faster than acetylene that contains 2,400 BTU/scf. Any continued belief on the dominance of the valence bond for all possible substances existing in the universe until the

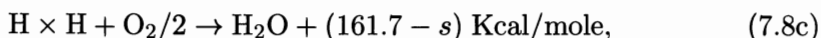
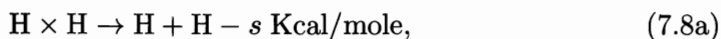

Figure 7.3. A picture of MagneGas produced from distilled water that cuts a 5'' (10 cm) thick metal plate faster than acetylene. The belief that said MagneGas has a conventional molecular structure would imply the gas to have about 240 BTU/scf, while acetylene possesses 2,400 BTU/scf, thus exiting the boundaries of science in favor of theologies. The sole possible quantitative interpretation is that MagneGas has Santilli's magnecular structure (Chapter 4) and, therefore, a magnecular combustion originating from a percentage of atoms being weakly bounded, thus being readily available for combustion (data from the U. S. public company MagneGas Corporation, www.magnegas.com).

end of time causes the exiting from the boundaries of quantitative science and the passage to personal theologies. The *only* possible explanation of the energy output of MagneGas being bigger than acetylene is that via Santilli's principles of magnecular combustion, namely, that based on the presence individual atoms under a weak bond or, equivalently, on the dramatic reduction of energy lost for molecular separation.

A fully similar situation occurs for the HHO gas (Section 4.4) that, according to quantum chemistry, should contain 210 BTU/scf, namely, an output of energy basically insufficient for the instantaneous melting of tungsten and bricks. The same excess energy output occurs for MagneHydrogen and all gases with magnecular structure.

To initiate a quantitative analysis, assume that the H-atom is bonded magnecularly with a yet unknown value of "s" Kcal/mole. We then have the following data for the combustion of $\text{MH}_2 = \text{H} \times \text{H}$ in oxygen:



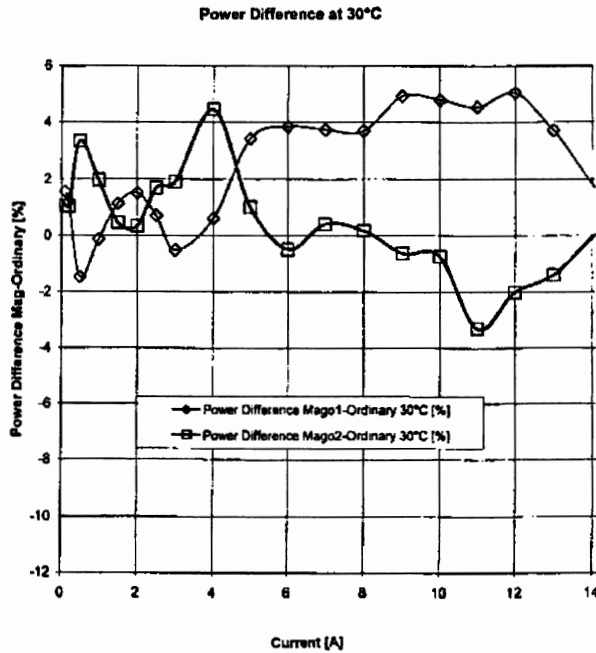

Figure 7.4. Increased energy output of a fuel cell obtained in 2000 by Santilli by using hydrogen separated from MagneGas. Similar increases of power were obtained via a conventional hydrogen treated with a special PlasmaArcFlow reactor (patented and international patents pending). The principle of the increased power is that of magnecular combustion and it is due to the decrease of energy lost for molecular separation, thus yielding a greater energy output. Despite several solicitations, the above discovery so manifestly important for the fuel cell industry was never repeated to date (Fall 2010) by the hydrogen and fuel cell industries, despite its quite moderate cost, the only credible motivation being that Santilli magnecular combustion is not compatible with organized interests in quantum chemistry.

namely, the combustion of magnecular hydrogen $H \times H$ and atomic oxygen O is predicted to yield about three times the value predicted by molecular structures with the same atomic constituents, under the approximation $s = 0$ at the combustion temperature.

It is easy to see that all mixtures of molecular H_2 and magnecular MH_2 yield a combustion energy output bigger than 57.5 Kcal/mole. As an example, a mixture of 10% MH_2 and 90% H_2 would yield $(62.71 - s)$ Kcal/mole.

It should be indicated that much remains to be studied in Santilli's magnecular combustion. In fact, despite its novelty, the magnecular combustion alone appears as being insufficient for a quantitative representation of large energy outputs, such as the instantaneous melting of tungsten and other metal by MagneGas, HHO, MH and other magnecular gases, that require additional novel notions, such as the

toroidal polarization of at least some of the orbitals for fast and deep penetration within metal structures.

7.3 New hadronic energies of nuclear type

7.3.A Foreword

In this section, we outline new clean energies that can be predicted and developed at the nuclear level via the use of hadronic mechanics, for which reason they are called *new hadronic energies of nuclear type*.

The main aspect is that all nuclear energies that could be conceived via the use of quantum mechanics were fully known by the middle of the 20th century and they all turned out as being environmentally unacceptable because of the production of harmful radiations, such as those composed by penetrating neutrons fluxes, and they released radioactive nuclear waste our society has been unable to dispose of in an environmentally acceptable way.

Santilli has: 1) studied existing nuclear energies for decades; 2) identified the insufficiencies of quantum mechanics in nuclear physics; 3) constructed a covering of quantum mechanics specifically conceived for nuclear structures; 4) predicted new form of nuclear energies without harmful radiations or radioactive waste that are inconceivable for quantum mechanics, but are predicted by the covering hadronic mechanics; 5) achieved their experimental verification and solicited their independent experimental confirmation.

Following over thirty years of preparatory mathematical and physical research, Santilli presented the first type of new, clean, hadronic energies of nuclear type in the 1999 and 2001 monographs and then in the 2008 memoir [125]. The experimental verification of the new energy with particular reference to the absence of neutron or other harmful radiations was achieved in the 2010 paper [131]. The independent experimental verification of the new energy with particular reference, again, to the absence of harmful radiations, was done also in 2010 by three nuclear physicists from a company in Princeton, New Jersey, and it is available in the paper [200]. A conceptual—nontechnical outline of the new energy is given by the paper [201].

7.3.B Insufficiencies of “cold” and “hot” fusions

Following the pioneering research by Fleishmann, Pons and Hawkins of 1989, vast research has been conducted on *Low Energy Nuclear Syntheses* (LENS) popularly called “Cold Fusion” (CF), reviewed in a large variety of publications not quoted here to avoid discriminatory listing.

Despite vast research, the field has remained controversial because of a rather widespread view that there is no sufficient evidence to conclude at this writing

that LENS do or do not occur due to claimed insufficient precision of available calorimeters, or the claimed lack of consistent reproduction of the results.

Additional reasons for the controversies are: claimed incompatibilities of LENS with pre-existing theories, despite the availability of new theories; denial of "cold fusions" on grounds of lack of emission of neutrons, while fusions without any emission of neutrons are possible; and other arguments.

Following extensive theoretical, experimental and industrial research in the field, Santilli's view is that LENS have indeed occurred in numerous tests, although the syntheses occurred at random, thus without hope of achieving industrial relevance, namely, the production of an energy surplus suitable to justify the construction of new electric power plants based on LENS. Recent additional experiments have confirmed the occurrence of LENS in laboratory, but the energy surplus necessary for industrial relevance has remained vastly elusive.

Additional research supported by a collective international investment of about one billion dollars over the past fifty years has shown that the *High Energy Nuclear Syntheses* (HENS), popularly called "Hot Fusion" (HF), can indeed be attained in laboratory, although the latter fusion too has not achieved industrial significance, and none is in sight at this writing, due to uncontrollable instabilities at the initiation of the fusion process, and other reasons.

In view of the decades of inability to achieve results of clear industrial value despite the expenditure of vast public and private funds, Santilli re-examined the foundations of fusion research, beginning with a *re-examination of the basic theories used for all nuclear fusions*, particularly in references to quantum mechanics, quantum chemistry and special relativity.

By keeping in mind the need by our society for new clean energies, and the fact that said disciplines were conceived and verified for conditions dramatically different than nuclear fusions, it is questionable to assume aprioristically and without serious scrutiny the exact validity of 20th century disciplines for fusion processes.

As recalled earlier, quantum mechanics, quantum chemistry and special relativity were conceived, constructed and verified for *reversible processes*, namely, processes whose time reversal images are causal, such as electron orbits in atomic structures, particles moving in accelerators, and many other systems. By contrast, all nuclear synthesis constitute strictly *irreversible processes*, namely, processes whose time reversal images violate causality and other laws.

As experts are expected to know for qualifying as such, the quantum mechanical probability amplitude for a Hermitean Hamiltonian is time reversal invariant. Consequently, quantum mechanics does predict a finite probability for two nuclei N_1 , N_2 , to fuse into a third nucleus N_3 with the consequential release of energy ΔE given by the difference between the initial and final rest energies

$$N_1 + N_2 \rightarrow N_3 + \Delta E, \quad (7.9)$$

$$\Delta E = E_3 - (E_1 + E_2). \quad (7.10)$$

However, in view of said time reversal invariance, quantum mechanics also predicts a finite probability for the *spontaneous* time reversal decomposition of the third nucleus into the original two,

$$N_3 \rightarrow N_1 + N_2, \quad (7.11)$$

in gross violation of the principle of conservation of the energy, causality, and other basic laws.

Consequently, any posture that strictly reversible theories, such as quantum mechanics, quantum chemistry and special relativity, are *exactly* valid for irreversible processes such as nuclear fusions, is *ascientific*, because the selection of irreversible covering theories more appropriate for the description of nuclear fusions is indeed open to scientific debate, but not their need.

7.3.C Santilli's main idea for new controlled fusions

In view of the above protracted insufficiencies at low and high energies, in his 2008 paper Santilli proposed, apparently for the first time, a new type of nuclear synthesis under the name of *Intermediate Controlled Nuclear Fusions* (ICNF), or "Intermediate Fusion" (IF) for short.

Recall that atoms are normally protected by their electron clouds and that nuclei have to be systematically exposed out of such clouds for their fusion to occur in a systematic fashion. A main shortcoming of the "cold fusion" is that the available energy is generally insufficient to control atomic electron clouds so as to expose nuclei, in which case no fusion is systematically possible.

For the case of the "hot fusion," we have the opposite occurrence in which atoms are completely stripped out of their electron clouds, but the energies are simply excessive, thus preventing the possibility of a real control of nuclear fusions, as well known in particle scattering processes in which excessive collision energies prevent absorption.

The name "intermediate" was proposed by Santilli to denote that the available energy is indeed intermediate between those of the "cold" and "hot" fusions, thus avoiding the shortcomings of both fusions. More particularly, the available energy for the proposed intermediate fusion is set to a threshold value, namely the *minimal* value of energy sufficient for the control of atomic clouds to expose nuclei, verify all conservation laws and control their synthesis.

The above conditions are verified, e.g., for the plasma created by an electric arc, which plasma is typically at about 10,000°F, thus having an energy that cannot be qualified as belonging to either the "cold" or the "hot" fusion. The energy is then carefully selected to have a additional minimal value for fusions to occur, so as to avoid the indicated impossibility for controlled fusions under excessive collision energies. Priority is then given to the identification of the

physical laws to be verified for systematic, industrially viable fusions and their engineering realizations.

It should be indicated that numerous plasmas have been used in “cold fusion” research. Nevertheless, dramatic differences will soon emerge between Santilli’s intermediate fusion and existing plasma fusion research, due to irreconcilable differences in the assumed basic laws. Santilli then proposed in his 1999 and 2001 monographs as well as in his 2008 specific reactors, called *hadronic reactors* because based on hadronic mechanics and chemistry, for the possible industrial utilization of the clean energy expected from his intermediate fusions.

To achieve this task, Santilli: 1) Identified the basic disciplines that are applicable to all controlled fusions, whether “cold,” “intermediate” or “hot”; 2) Identified the basic laws that have to be verified for any controlled fusion to occur; and 3) Proposed in manufacturing details specific hadronic reactors based on the realization and optimization of said physical laws.

7.3.D *Insufficiencies of quantum mechanics, quantum chemistry and special relativity for controlled fusions*

In his 2008 memoir, Santilli confirmed his preceding studies on the lack of exact character of 20th century theories for nuclear fusions, and pointed out that basically new, potentially clean energies are expected to be predictable by *deviations* from said theories, no matter how small. These insufficiencies have been outlined in Chapter 1 of this volume and studied in details in the subsequent chapters. Therefore, they will be considered as being known hereon.

It should be indicated that Santilli moves no main objection in the use of quantum mechanics for *nuclear fissions* because, in this case, the debris of the fission can be effectively represented as being massive points moving in the inter atomic vacuum, thus allowing a serious applicability of the mathematical and physical foundations of quantum mechanics. Santilli moves objections against the assumption of quantum mechanics as being exactly valid for *nuclear fusions* because, unlike the case of fissions, nuclei cannot any longer be credibly approximated as being massive points since they must be fused together.

As a matter of fact, we shall show below that the inability of “cold fusion” to achieve industrial relevance is mostly due to the excessive approximation of nuclei as massive point, an approximation absolutely necessary for the applicability of the foundations of quantum mechanics, because said approximation causes the violation of basic physical laws for all fusions, such as the proper spin couplings of *extended* nuclei, which coupling become unnecessary under point-like abstractions.

Among the various formulations of hadronic mechanics specifically applicable to nuclear physics, we shall tacitly use in the memoir [109] for the Lie-isotopic case, namely, for the structure of stable nuclei and the additional memoir [120]

for the broader irreversible case, namely, for the study of unstable nuclei and nuclear fusions.

7.3.E *Insufficiencies of quark and neutrino conjectures for controlled nuclear fusions*

In his 2008 memoir, Santilli reviews the negative implications, particularly for the conception of new clean nuclear energies, caused by the indiscriminate assumption of quarks and neutrinos as being physical particles existing in our spacetime without a serious scrutiny.

As reviewed earlier, Santilli accepts as final the Mendeleev-type *classification* of hadrons into families achieved by $SU(3)$ -color models, confirms the need of quarks for their elaboration, but assumes that quarks are what they technically are: purely mathematical entities characterized by mathematical representation of a purely mathematical symmetry defined on a purely mathematical, complex-valued internal space that, as such, dismiss any hope of quantitative definition in our spacetime. In any case, Santilli recalls the impossibility for quarks to have gravity as conceived by Einstein, and other basic shortcomings reviewed earlier.

The 2008 memoir then points out the negative implications for the conception of new energies whenever protons and neutrons, thus nuclei, are assumed as being composite systems of quarks as physical particles in our spacetime. These implications will perhaps appear more forcefully in the next section when studying the new energies originating in the structure of individual hadrons, rather than in their collection.

The 2008 memoir then suggests caution in the additional assumption of the plethora of neutrinos predicted by the standard model as being physical particles in our spacetime. In this respect, Santilli first recalls the basic insufficiency of the historical Pauli-Fermi hypothesis for a quantitative representation of the first and most fundamental synthesis in nature, that of the neutron from a hydrogen gas studied in details in the preceding chapter.

Santilli then illustrates the insufficiencies for the plethora of hypothetical, massive and oscillating neutrinos predicted by the standard model and the dependence of any model of clear fusion from neutrino conjecture whenever the latter are assumed as physical particles in our spacetime. The evident argument is that, once the insufficiency of the hysterical Pauli-Fermi hypothesis of the neutrino are technically identified for the fundamental synthesis of the neutron, the corresponding insufficiencies for all subsequent nuclear fusions become transparent and compelling.

In view of the above, Santilli certainly does not object on the continuation of research on nuclear fusions based on the assumption of quarks and neutrinos as physical particles, but strongly recommend the joint research without the assumption of hypothetical particles and the use instead of covering theories,

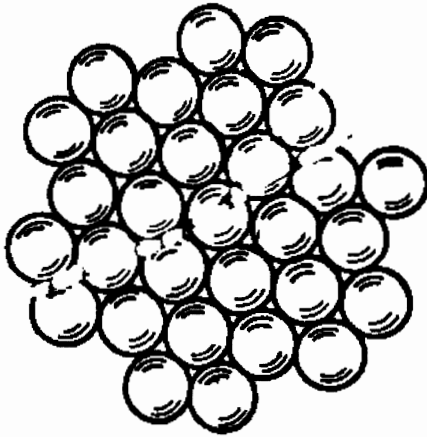

Figure 7.5. A reproduction of Figure 6.24 often used by Santilli to illustrate that “nuclei have no nuclei” being composed by extended constituents in contact with each other (technically, in conditions of mutual penetration of about 10^{-3} of their charge distributions). Consequently, the nuclear force is expected to be partially of potential and partially of nonpotential type, with ensuing nonunitary character of the theory, and related applicability of hadronic mechanics.

since the comparison of the two approaches clearly shows the capability by the latter of predicting new clean energies that are prohibited for the former.

With regard to the above aspects, a pre-requisite for the technical understanding of the ICNF and their industrial development is a study of the paper [123].

7.3.F Basic assumptions of intermediate controlled nuclear fusions

Following the preceding studies, in his 2008 memoir, Santilli makes the following basic assumptions for his ICNF:

1) **Nuclear force.** Virtually the entire 20th century research in nuclear physics, thus including research in “cold” and “hot” fusions, has been based on the assumption that the nuclear force is *entirely* derivable from a potential. Consequently, all nuclear structures and their processes were entirely represented with a Hamiltonian, a condition evidently necessary for the applicability of quantum mechanics. By contrast, Santilli central assumption is that part of the nuclear force is indeed of action-at-a-distance, potential type representable with a Hamiltonian, and part is of contact, nonpotential type that cannot be represented with a Hamiltonian. This central assumption implies that the time evolution of nuclear structure and processes is necessarily of *nonunitary* type. The use of the various branches of hadronic mechanics then emerges as the only known axiomatically consistent and time invariant nonunitary formulations of nuclear structures and their processes.

2) **Stable nuclei.** In this case, Santilli assumes the *Lie-isotopic branch of hadronic mechanics* based on the dynamical equations he proposed in 1978 when a member of Harvard University for stable, reversible, interior dynamical problems, today known as *Heisenberg-Santilli Lie-isotopic equations* here recalled for the time evolution of a Hermitean operator A in the infinitesimal and finite forms (see Section 3.11 for detailed treatments and references)

$$i \frac{dA}{dt} = [A, H] = ATH - HTA, \quad (7.12a)$$

$$A(t) = \exp(HTti)A(0) \exp(-itTH), \quad (7.12b)$$

in which: the Hermitean Hamiltonian

$$H = \frac{p^2}{2m} + V(r) \quad (7.13)$$

represents all possible nuclear forces truly derivable from a potential $V(r)$; the isotopic element T represents all contact nonpotential interactions allowing a nuclear structure with all constituents in actual contact of each other, and simplest possible realizations of the type

$$T = \exp \left(-F(r) \int \psi^\dagger(r) \psi(r) d^3r \right) > 0, \quad (7.14)$$

recovering quantum mechanics identically and uniquely when there is no appreciable overlapping of the wavefunctions ψ of nuclear constituents; and the inverse of the isotopic element,

$$\hat{I} = 1/T > 0, \quad (7.15)$$

represents the basic, right and left unit of the theory at all levels, including numbers, differential calculus, functional analysis, etc. The presence of contact, non-Hamiltonian interactions is then assured by nontrivial values of T . The stability of the nucleus (reversibility over time) is represented by the identity of the basic isounit to the right and to the left, namely, for motions forward and backward in time.

3) **Unstable nuclei and nuclear fusions.** In this case, Santilli assumes as the main discipline the *Lie-admissible branch of hadronic mechanics* with basic dynamical equations he also proposed in 1978 and today known as *Heisenberg-Santilli Lie-admissible equations* here presented for the time evolution of a Hermitean operator A also in their infinitesimal and finite forms

$$i \frac{dA}{dt} = (A, H) = ARH - HSA, \quad (7.16a)$$

$$A(t) = \exp(HSti)A(0) \exp(-itRH), \quad (7.16b)$$

where H continues to be Hermitean although it now represent the *nonconserved* total energy, and the nonpotential interactions are represented by the genotopic elements R and S . Irreversibility is assured in this case by the different values of the genounit for forward (f) and backward (b) motions in time,

$$I^f = 1/R \neq {}^bI = 1/S. \quad (7.17)$$

In this case, the Lie-admissible branch of hadronic mechanics is ideally suited to represent the decay of unstable nuclei as well as nuclear fusions, since both are irreversible over time.

4) **Neutron synthesis.** As recalled earlier, stars initiate their lives as being composed of hydrogen; then they first synthesize the neutron from the compressed hydrogen gas; and then they synthesize all natural elements. Consequently, the synthesis of the neutron is the first and most fundamental nuclear synthesis. For this reason, Santilli spent decades of his research life for a quantitative understanding of the synthesis of the neutron from a proton and an electron, resulting in the reaction studied in details in the preceding chapter



where “ a ” represents *Santilli’s etherino* which is not intended as being a physical particle, but rather to represent in a *conventional* Hilbert space the transfer of 0.782 MeV and spin 1/2 missing in the synthesis of the neutron from the environment to the neutron structure.

To understand the new hadronic energies, the reader should keep in mind the impossibility of using the Pauli-Fermi neutrino conjecture for the synthesis of the neutron due to the inconsistency of the conventional Schroedinger’s equation under the *positive* potential (see the preceding chapter for details).

To reach a more technical understanding of the new energies, the reader should also know that the etherino disappears at the covering level of hadronic mechanics and the formulation of the neutron synthesis on a iso-Hilbert space over an isofields.

Finally, the reader should meditate a moment on the origin of the missing 0.782 MeV for the synthesis of the neutron because, in the event such energy is provided by the environment, a star would never start producing light due to enormous energy needed for the synthesis of an enormous number of neutrons, This lead Santilli to a return to a continuous creation in our universe with the missing energy provided by the ether as a universal substratum (see the preceding chapter for details).

5) **Nuclear structure.** Rather than attempting to achieve the joint classification of baryons into a family and the structure of each members of the baryonic family via three hypothetical quarks, Santilli assumes the unitary classification of baryons as valid, but introduces new structure models of each member of the

baryonic family with *physical* constituents, namely, constituents that can be produced free thus being detected by our instruments in our spacetime. Resolution of historical objections is merely achieved by assuming that, when in interior conditions (only), barionic constituents obey covering mechanics and symmetries with ensuing *mutations* (denoted with an asterisk) of their *intrinsic* characteristics. In particular, Santilli assumes the proton as an elementary stable particle without known structure (in view of its stability), and assumes the neutron as an unstable particle composed by one proton \widehat{p}^+ and an electron \widehat{e}^- in mutated conditions due to their total mutual immersion and resulting synthesis

$$n = (\widehat{p}^+, \widehat{e}^-)_{\text{hm}}, \quad (7.19)$$

as described in details in Section 6.3, hereon assumed as known.

Consequently, Santilli assumes that nuclei are indeed a collection of protons and neutrons, but only in first approximation, while being at a deeper level a collection of mutated protons and mutated electrons. As we shall see, the latter assumption alone allows far reaching studies on new clean energies.

7.3.G *Physical laws of controlled nuclear fusions*

One of the first contributions of hadronic mechanics, hadronic chemistry and isorelativity to new clean nuclear energies is the identification, apparently for the first time, of basic physical laws that have to be obeyed by all nuclear fusions to occur in a *systematic* (rather than in a random) way. Such laws must then be subject to engineering realization and optimization for nuclear fusions to acquire industrial value. Said laws apply for all fusions, thus for “cold,” “intermediate” and “hot” fusions, they were first published in the 1999 monograph, are referred to in the literature as *Santilli’s laws for controlled nuclear fusions*. Let us begin with the following:

DEFINITION 7.3G: Controlled Nuclear Fusions (CNF) are given by systematic energy releasing nuclear fusions whose rate of synthesis (or of energy output) is controllable via one or more mechanisms capable of performing the engineering optimization of the applicable laws.

We are not in a position to review here the derivation of the basic laws of CNF to avoid a prohibitive length and we merely provide their conceptual outline with a few comments (for a more detailed treatment one may study the 2008 memoir).

LAW I: A necessary condition for CNF to occur is to control the orbitals of peripheral atomic electrons in such a way to allow nuclei to be systematically exposed. Nature has set matter in such a way that nuclei are shielded by their atomic clouds. It is evident that a “nuclear” synthesis between two conventional “atoms” is impossible at low energies because the electron clouds will never allow nuclei to approach each other, let alone to synthesize a new nucleus. This law explains the inability of the “cold” fusions to achieve industrial

significance in energy output because, by definition, “cold fusions” do not have the energy necessary for the ionization of atoms. This law also illustrates the need for the proposed “intermediate fusions” in which the first energy requirement is precisely the control of atomic clouds.

LAW II: CNF only occur among nuclei whose spins are either in “singlet planar coupling” or “triplet axial coupling” (see Figure 7.6). This law illustrates the structural differences between quantum and hadronic mechanics, as well as the necessity of the latter for CNF to occur systematically. The constituents of a bound state of two quantum particles must necessarily be point-like to avoid structural inconsistencies beginning with the local-differential topology. Consequently, singlet and triplet couplings are equally possible for quantum mechanics. When the actual extended character of the constituents is taken into account, it is easy to see that *triplet planar couplings of extended particles at short distances are strongly repulsive, while singlet planar couplings are strongly attractive*, where the word “planar” is intended to indicate that the two nuclei have a common median plane, while “axial” indicates a common axial symmetry (Figure 7.6). This law was introduced by Santilli in the original 1978 proposal to build hadronic mechanics via the so-called *gear model*. In fact, the coupling of gears in triplet (parallel spins) causes extreme repulsion, while the only possible coupling of gears is in singlet (antiparallel spins). The emergence of a strongly attractive force for the singlet planar or triplet axial couplings is one of the fundamental contributions of hadronic mechanics to fusion processes since such a force is totally absent for quantum mechanics, while it appears naturally in all spinning and deeply overlapping particles, as established in the Cooper pair in superconductivity, the valence bonds in chemistry, the synthesis of neutrons from protons and electrons, the strong nuclear binding energy, and other cases.

LAW III: The most probable CNF are those occurring at threshold energies (namely, at the minimum value of the energy of the original nuclei needed to verify all laws). This hadronic law evidently identifies the main reason for the proposed “intermediate nuclear fusions.” A main reason of the law is that all energies below said threshold value do not allow industrially meaningful nuclear syntheses (this is the case for “cold” fusions), and all energies above the indicated threshold value cause instability that reduce the rate of synthesis in a way proportional to the energy excess (this is the case for “hot” fusions). As we shall see, the lack of engineering implementation of this law constitutes another reason “cold” and “hot” fusions have not achieved industrial relevance until now.

LAW IV: The most probable CNF are those without the release of massive particles (such as protons, neutrons and alpha particles). This law was not expected by Santilli. Yet, contrary to popular beliefs, explicit calculations based on hadronic mechanics indicated that the probability of a

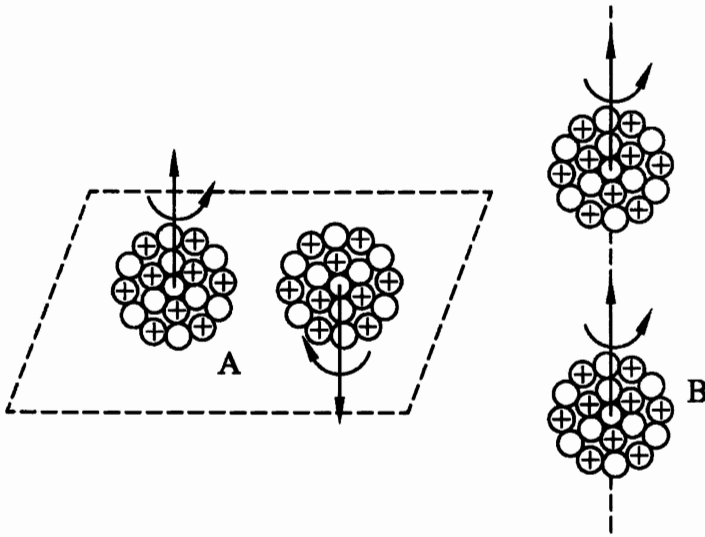

Figure 7.6. A schematic view of the only two stable couplings permitted by hadronic mechanics for nuclear fusions, the “singlet planar coupling” of the l.h.s. and the “triplet axial coupling” of the r.h.s. All other spin configurations have been proved to produce strongly “repulsive” forces under which no CNF is systematically possible.

nuclear synthesis with the release of neutrons is much *smaller* than that of another synthesis without the emission of massive particles. This law has been verified by ICNF achieved to date and, apparently, this law appears to be verified by nuclear syntheses spontaneously occurring in nature. It should be stressed that this law does not preclude the study of CNF with secondary emission of massive particles. It only suggests the preferred study of nuclear syntheses without release of massive particles for evident environmental reasons.

LAW V: CNF cannot occur without a “trigger,” referred to an external mechanism forcing exposed nuclei to pass through the hadronic horizon. All nuclei are positively charged, thus repelling each other at distances bigger than one Fermi. Without a mechanism that overcomes the Coulomb repulsion and brings nuclei inside the hadronic horizon, no nuclear synthesis is evidently possible. By contrast, when inside the hadronic horizon and the preceding laws are verified (with particular reference to law II on spin couplings), the synthesis is inevitable due to the activation of the strongly attractive hadronic forces that overcome the repulsive Coulomb force. The case is similar to that of identical valence electrons that evidently repel each other for all distances bigger than one Fermi (range of validity of quantum mechanics and potential interac-

tions), but strongly attract each other at mutual distances less than one Fermi (range of validity of hadronic mechanics and nonpotential interactions).

It is instructive to examine a representative case of “cold” fusion under the above physical laws. Consider the Fleishmann-Pons electrolytic cell. It is easy to see that this cell does indeed verify the conservation of the energy, the conservation of the angular momentum, and admits a trigger characterized by the electrostatic pressure compressing deuterium inside the palladium.

However, Fleishmann-Pons electrolytic cell does not verify Laws I (control of atomic clouds to expose nuclei), Law II (control of spin couplings) and other laws. In fact, nuclear spin couplings occur at random, there is no clearly identified mechanism to expose nuclei, and there is an equally clear lack of optimization of the verified laws. Consequently, nuclear syntheses occur at random, thus preventing industrial values of the energy output.

It is an instructive exercise to inspect other realizations of “cold” fusions among the large variety existing in the easily identifiable literature (not quoted here to avoid discriminatory listings). One can see in this way that, to our best knowledge at this time, none of available “cold” fusions realizes “all” basic hadronic laws (the indication of the contrary would be appreciated).

7.3.H The role of Santilli magnecules for controlled nuclear fusions

Inspection of CNF Laws I-V reveals that the most difficult engineering realization is that of Law I on the systematic control of electron clouds to expose nuclei as a pre-requisite for their fusion. Following a decade of research, and thanks to large private funds, Santilli achieved industrial maturity for gaseous and liquid fuels via the new chemical species of magnecules studied in details in Chapter 4, currently sold in various countries by a number of corporations (see www.magnegas.com).

As illustrated in Figure 7.7, Santilli magnecules do indeed achieve the desired systematic and controlled exposure of nuclei in such a way to be naturally set to verify Law II on the spin coupling. In particular, said coupling is of axial triplet type, namely, the most efficient for nuclear fusions to our knowledge.

Rather remarkably, Santilli has indicated various times in his writings that the new chemical species of magnecules was conceived as a necessary preparatory step for the achievement of his intermediate controlled fusion. Inspection of Figure 7.7 indicates that, when atoms are reduced to toroids and aligned in axial triplet coupling, nuclear fusion merely require an external action, the trigger, to push nuclei at one Fermi mutual distance at which point the strongly attractive nuclear force is activate and fusion becomes inevitable.

For notational purposes, we recall that conventional valence bonds are indicated with the symbol “-”, while Santilli magnecular bonds are indicated with

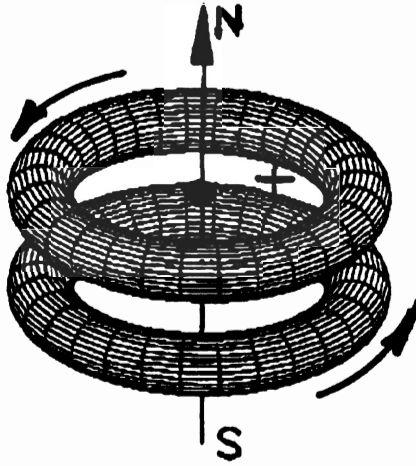
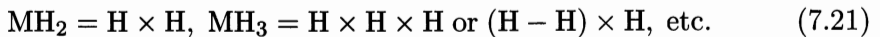

Figure 7.7. A reproduction of Figure 4.11 to illustrate the fundamental role of Santilli magneucleus for controlled nuclear fusion since they assure the correct spin coupling as per Law II.

the symbol “ \times ”. Hence, the hydrogen molecule is indicated with the usual symbol



while magneuclear hydrogen, denoted with the symbol MH_n is written (see Chapter 4 for more details)



It is possible to see that, under suitable engineering optimization studied in the next sections, the magneuclear structure of Figure 7.7 also allows the verification of the remaining laws of controlled nuclear fusions.

7.3.1 Engineering conception and realization of hadronic refineries

Santilli has conceived and constructed the the following two types of equipment:

1) *Hadronic Refineries* denoting an equipment suitable for the recycling of liquid wastes into a gaseous fuel with magneuclear structure (called *magnegases*) via a submerged electric arc; and

2) *Hadronic Reactors*, denoting an equipment primarily devoted for the production of industrially significant heat via an electric arc submerged within a properly selected fluid.

Both reactors have the name “hadronic” because based on a submerged electric arc that, as such, requires the use of hadronic mechanics and chemistry due to excessive deviations from quantum mechanics (see Chapters 1 and 4).

In this section, we outline engineering details on hadronic refineries, and pass later on to the more complex hadronic reactors of main interest for this chapter. The waste used in refineries is called *liquid feedstock*, while the gas used in reactors is called *hadronic fuel*.

One of the biggest engineering difficulties for the industrial production of the new chemical species of Santilli magnecules, whether for hadronic refineries or reactors, is that the toroidal polarization of spherical atomic orbitals requires very strong magnetic fields of the order of billions of Gauss, which fields have to be realized in an industrially viable and cost effective way (for details, see Appendix 8A of the 2001 monograph). The solution identified by Santilli following long studies is that via the use of DC electric arcs submerged within a properly selected liquid feedstock.

With reference to Figure 7.8, at atomic distances from the DC arc with 100 kW power, the magnetic field can reach values of 10^{11} Gauss or more, thus being sufficient for the desired polarization of atomic orbitals. Additionally, said magnetic field naturally couples polarized atoms into magnecules with triplet axial coupling North-South-North-South-... . Finally, the arc compresses magnecules toward its axial symmetry at the time of its disconnect and re-initiation (for reasons not entirely understood so far), thus favoring the realization of the “trigger” for the systematic achievement of nuclear syntheses.

In figure 7.9, we provide the conceptual lines of hadronic refineries of current industrial production consisting of a metal vessel capable of withstanding pressures up to 300 psi; the vessel is filled up with the selected liquid feedstock, and houses a DC electric arc among one or more pairs of electrodes that are submerged within the selected fluid and feedstock powered by an external AC-DC converter with at least 50 Kw. Electrodes are selected depending on the need at hand. For instance, in the event carbon is needed to stabilize the fuel produced or for nuclear syntheses, the electrodes can be composed of commercially available graphite.

The equipment includes means for the continuous recirculation of the liquid feedstock through the arc so that magnecular structures are continuously removed from the arc following their creation. In the case of a liquid feedstock, the submerged arc produces a clean burning, cost competitive magnecular fuel that bubbles to the surface where it is collected for use (see web site of the U. S. public company Magnegas Corporation www.magnegas.com and/or additional technical details, one may inspect Santilli’s various U. S. Patents in the process known as *PlasmaArcFlow*).

The heat produced by the reactor is acquired by the liquid feedstock and it is used via its recirculation through an external heat exchanges that can power a turbine for the production of electricity (following additional input to the steam to reach supercritical temperatures) or other uses. The equipment is completed

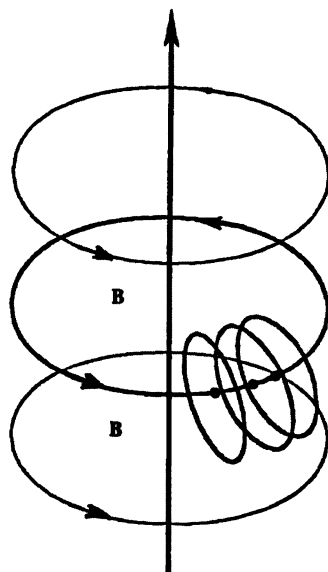

Figure 7.8. A schematic view of the geometry of a DC electric arc represented by the vertical line with the associated magnetic field represented by horizontal circles, and the created magnecules represented by circles perpendicular to the magnetic lines. This geometry has the following primary implications: 1) Since the magnetic field M is proportional to I/r , one can see that at atomic distances from electric arcs with one thousand Amperes of current, the magnetic field is of the order of 10^{11} Gauss, thus being sufficient to polarize atomic orbitals into toroids, and then coupling them into magnecules.

by means for the automatic control of all operations, including the control of the DC power, the pressure, temperature, flow, and other means.

The efficiency of hadronic refineries is quite big and not entirely understood until now. In essence, the arc turns the liquid feedstock into a gaseous state; decomposes the gas molecule into their atomic constituents; ionizes the resulting atoms; and forms a plasma at about $10,000^{\circ}\text{F}$ composed of ionized H, O, C and other atoms, ionized dimers OH and CH, and ionized ordinary molecules. The known affinity between C and O creates C – O in single, double and triple bonds, the combustion in part of C – O into CO_2 , the synthesis of H – H and other esoenergetic reactions.

Because of the above features, *Santilli's hadronic refineries provide a new form of carbon combustion that is cleaner and more efficient than conventional carbon combustion*, e.g., in the boiler of an electric power plant. In fact, the produced gaseous fuel is cleaned via its passage through the liquid feedstock. the trapped impurities being recycled by the arc, thus providing a form of carbon combustion cleaner than existing combustion. Santilli's carbon combustion is also more

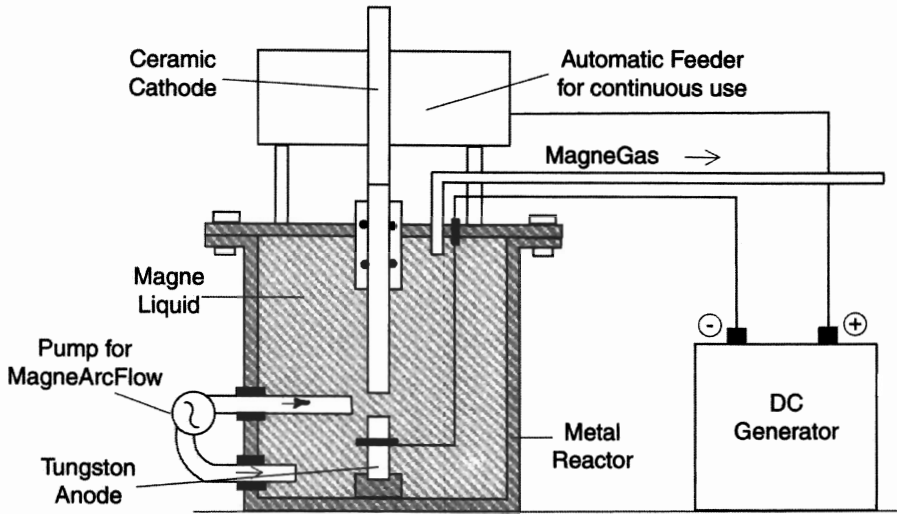

Figure 7.9. The main lines of Santilli hadronic refineries converting liquid waste into a clean burning, cost competitive gaseous fuel with magnecular structure, showing: the pressure metal vessel; the submerged electrodes; the recirculation of the feedstock through the arc; the external AC-DC converter; the external automatic controls of the arc; and the collection of the produced magnecular fuel.

esoenergetic than conventional forms for the evident reason that the latter solely allow conventional chemical reactions for CO , CO_2 and other lesser relevant reactions, while the former admits additional very esoenergetic reactions such as the synthesis of H_2 as well as of magnecules.

The existence of clearly anomalous species is easily established Santilli hadronic refineries because in using pure graphite electrodes within distilled water, the maximal species predicted by quantum chemistry is CO_2 with 44 amu, while clusters in macroscopic percentages are detected all the way to 500 amu, with detection and all the way to 1,000 amu in lesser percentages, which clusters can only be Santilli magnecules. Additional large deviations from quantum chemistry are visible in the exhaust and other aspects.

To conduct measurements, Santilli [loc. cit.] has introduced first the *Scientific Efficiency (SE)* defined as the ratio between the energy output (given by the heat energy contained in magnegas E_{mg} plus the heat acquired by the liquid feedstock E_{fs}) and the energy input (given by the electric energy E_{el} used by the refineries plus the energy released by carbon combustion and the other above indicated reactions E_{cc}),

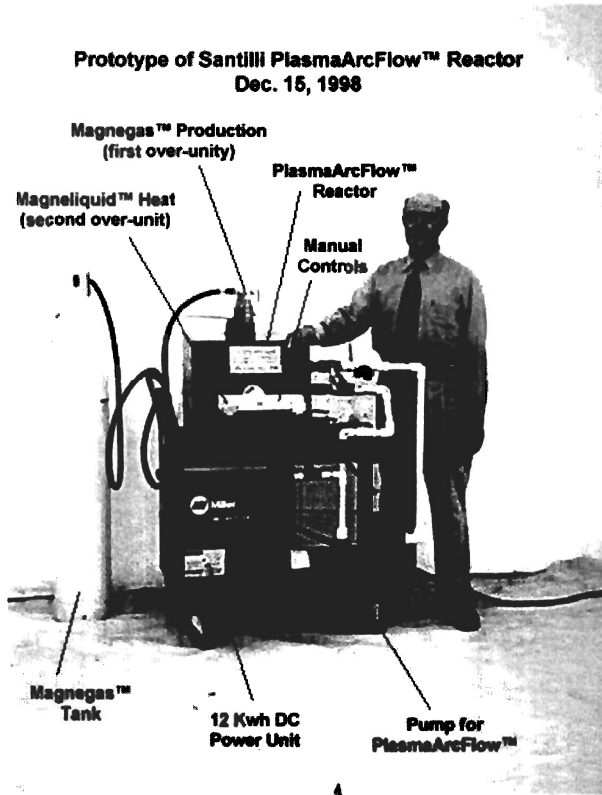

Figure 7.10. Picture of Prof. Santilli with the prototype of hadronic refineries he built in Florida in late 1998.

$$SE = \frac{E_{mg} + E_{fs}}{E_{el} + E_{cc}} < 1, \quad (7.22)$$

which efficiency is evidently smaller than one because of the conservation of the energy, dispersions and other reasons.

However, oil waste is very rich in carbon and its recycling not only has no cost, but actually brings an income. For this reason, Santilli introduced the *Commercial Efficiency (CE)* given by the preceding definition with the sole electric energy in the denominator since it is the sole carrying a cost,

$$CE = \frac{E_{mg} + E_{fs}}{E_{el}} > 1. \quad (7.23)$$

The latter efficiency can be greater than one, as established by certified and independent measurements, because the energy produced by the combustion of the carbon in the plasma of the arc is much bigger than the electric energy used



Figure 7.11. Picture of a mobile 50 Kw hadronic refinery pulled by an SUV built by Prof. Santilli in summer 2005.

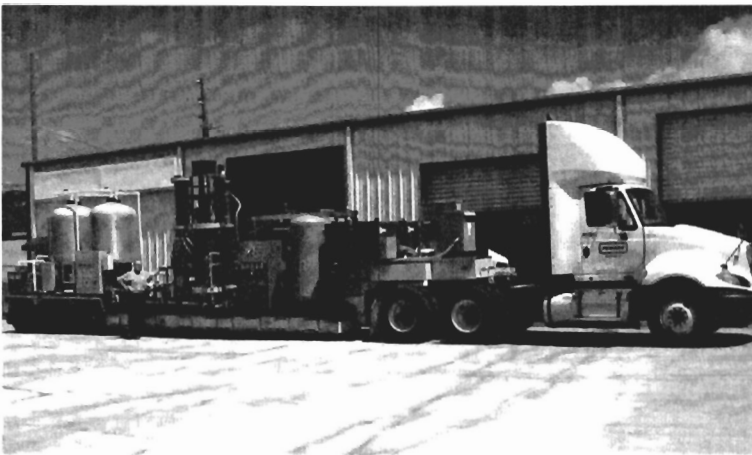

Figure 7.12. Picture of Prof. Santilli with an industrial hadronic refinery delivered to China in Spring 2010.

by the arc. Note that this value bigger than one occurs also in using distilled water as a feedstock since the carbon is supplied by the graphite electrodes.

As an illustration with data verifiable at the laboratory of the *Institute for Basic Research* in Florida, a hadronic refinery operating with 100 Kw, 100 psi pressure, and 200°F for the recycling of an oil-base liquid feedstock (such as

automotive oil waste, biodiesel byproducts, frying oil waste, etc.) produces mag-negas at the rate of about about 1,500 scf/h = 42,000L/h corresponding to about 1,350,000 BTU/h, plus heat acquired by the liquid feedstock of about 600,000 BTU/h, while using 100 Kwh that correspond to about 340,000 BTU/h. In this case the scientific efficiency is, evidently, smaller than one, but the commercial efficiency is bigger than one and given by

$$CE = \frac{E_{mg} + E_{fs}}{E_{el}} = \frac{1,350,000 + 600,000}{340,000} = 5.73, \quad (7.24)$$

which value establishes the industrial relevance of hadronic refineries due to their large efficiency.

The reader should be aware that commercial efficiencies (as above defined) of the order of 10 have already been measured in prototypes because the total net energy output of hadronic refineries increases nonlinearly with the increase of the operating power, pressure and temperature.

7.3.J *The physics of intermediate controlled nuclear fusions*

The physics of ICNF was first presented by Santilli in the 1998 monograph, studied from a chemical viewpoint in the 2001 monograph, and then finalized in the 2008 memoir. In this section we review these studies based the following main assumptions:

ASSUMPTION I: The synthesis of neutrons from protons and electrons is the first and most fundamental synthesis in nature. Nuclear fusions can only follow that of the neutron. Hence, no nuclear fusion is expected to occur at energies intermediates between the “cold” and the “hot” fusions unless reactors are capable of achieving the neutron synthesis. Consequently, ICNF should take into consideration possible contributions from the synthesis of neutrons from protons and electrons.

ASSUMPTION II: Quantum mechanics is fundamentally inapplicable to the neutron synthesis as well as that of all nuclear syntheses at large due to its reversible structure compared to the irreversibility of the syntheses considered and for many other reasons (Chapters 1, 3, 6). Consequently, any appraisal of nuclear fusions basically dependent on quantum descriptions cannot be final.

ASSUMPTION III: Operator mechanics applicable to nuclear fusions should first achieve a time invariant numerical representation of all characteristics of the fundamental synthesis of neutrons from protons and electrons, as a condition to be applicable to subsequent nuclear syntheses. Hadronic mechanics is the only mechanics verifying these pre-requisites to our knowledge at this writing. Other theories are dismissed by Santilli unless: 1) they achieve said “numerical” representation of “all” characteristics of the neutron; 2) said representation

is invariant over time (predict the same numbers under the same conditions at different times); and 3) is proved to be inequivalent to hadronic mechanics.

The guidelines for the conception of hadronic reactors has been based on nature, rather than on pre-existing research. As established by chemical analyses of air bubbles in amber, about one hundred millions years ago Earth's atmosphere had about 40% nitrogen, while its current percentage is about double that value. Other chemical analyses show that the increase of nitrogen in our atmosphere has been gradual.

In Santilli's view, these data suggest *the apparent existence in our atmosphere of a process causing the natural synthesis of nitrogen from lighter elements*. Since nature is notoriously friendly toward the environment, such a process is expected to synthesize nitrogen without the release of of harmful massive radiation such as neutrons, protons and alpha radiations, from, which ICNF Law VI was derived.

Among all possible origins of a nitrogen synthesis in our atmosphere, the most probable one is given by *lighting*, because a serious scientific (that is, quantitative) explanation of *thunder* cannot be achieved with conventional physical and chemical reactions, thus requiring nuclear syntheses. In fact, a numerical explanation of thunder requires energy equivalent to hundreds of tons of explosives that simply cannot be explained via conventional processes due to the very small cylindrical volume of air affected by lightning plus its extremely short duration of the order of nanoseconds.

The nitrogen syntheses by lighting provides indeed a numerical explanation of thunder as well as the slow rate of nitrogen increase in our atmosphere. Among all possible syntheses, the most probable one results to be the *synthesis of nitrogen from carbon and deuterium*. However, the deuterium presence in our atmosphere is excessively small to permit a numerical explanation of thunder. It is at this point where the synthesis of neutrons by lighting from protons and electrons enters rather forcefully into the arena of nuclear syntheses.

In fact, the neutron synthesis is expected to be a necessary pre-requisite for the synthesis of deuterium in atmosphere that, in turn, allow nitrogen syntheses with values sufficient to reach a numerical explanation of thunder. At any rate, Santilli succeeded in synthesizing neutrons from protons and electrons precisely via the use of an electric discharge in a hydrogen gas (Chapter 6). Needless to say, numerous additional fusions are also possible under lighting and some of them will be indicated below.

Hadronic reactors have been conceived to reproduce lighting processes within a gas as close as technically possible at the moment. In the authors view, the biggest unknown at this writing is not given by the identification of possible nuclear syntheses triggered by lighting, but by our insufficient knowledge of lighting itself due to departures from quantum mechanics while studies via the covering hadronic mechanics are not yet completed at this writing.

The successful achievement of ICNF with industrial relevance crucially depends on the proper selection of the *hadronic fuel*. In this section, we study a few examples of hadronic fuels selected under the conditions that:

- 1) *The original and final nuclides are light, natural, and stable isotope;*
- 2) *The nuclear syntheses cause no emission of harmful radiations, such as n , p , α , etc.; and*
- 3) *The energy produced ΔE is much bigger than the total energy used by the equipment for its production.*

Note the difference between the conventional *nuclear fission*, where the emphasis is in the use of *large, often unstable isotopes*, and the proposed novel hadronic energy, where the emphasis is in the opposite selection of *isotopes as light and stable as possible*. As indicated earlier, the latter emphasis is necessary to achieve a basically novel *nuclear energy without harmful radiations and without harmful waste*. Santilli has shown that these main objectives are indeed realistic, not via the use of quantum theories, but via the use of the covering hadronic mechanics and its laws for.

By using standard nuclear terminologies and symbols with: A , Z , J^p , u denoting the atomic number, the nuclear charge, the nuclear angular momentum, the parity, and the nuclear energy in amu units, respectively, the ICNF proposed by Santilli are of the generic type

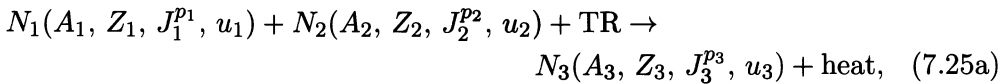

$$A_1 + A_2 = A_3, \quad Z_1 + Z_2 = Z_3, \quad J_1 + J_2 = J_3, \quad p_1 + p_2 = p_3, \quad (7.25b)$$

$$\Delta E = E_3 - (E_1 + E_2) > 0, \quad (7.25c)$$

where E is measured in units “u”, TR denotes the “trigger” and the heat is essentially produced by the release of excited states of the synthesized nucleus N_3 under energies insufficient to produce massive radiations.

It should be stressed that a number of alternatives to the above synthesis are possible, particularly those based on intermediates processes such as Electron Capture (EC), or emission of electrons that is not considered harmful since electrons can be stopped with a thin metal shield. Needless to say, in the latter cases, the conservation of the charge is different than that in Eq. (7.25).

The following unit conversions may be helpful:

$$1 \text{ u} = 931.494 \text{ MeV};$$

$$1 \text{ MeV} = 1.602 \times 10^{-13} \text{ J} = 4.45 \times 10^{-17} \text{ Wh} = 1.511 \times 10^{-16} \text{ BTU}; \quad (7.26a)$$

$$1 \text{ Wh} = 3.397 \text{ BTU}; \quad 1 \text{ C} = 6.241 \times 10^{18} \text{ e}; \quad 1 \text{ A} = \frac{1 \text{ C}}{1 \text{ s}}, \quad (7.26b)$$

where “ e ” is the elementary charge of the electron. The energy used by a 50 Kwh hadronic reactor is given by

$$50 \text{ Kwh} \approx 1.69 \times 10^5 \text{ BTU.} \quad (7.27)$$

Hence, to be industrially relevant, hadronic reactors must produce energy at an hourly rate much bigger than that used for their operations.

Santilli then first studies the synthesis of nitrogen as expected in lighting. The simplest reaction with related energy output is given by:

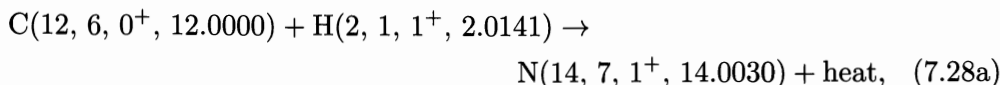

$$\Delta E = (E_C + E_H) - E_O = 0.0111 \text{ u} = 10.339 \text{ MeV} \approx 1.5 \times 10^{-15} \text{ BTU}, \quad (7.28b)$$

where very light elements, such as hydrogen and helium, are expected to be completely ionized at the intermediate energies needed for the ICNF, namely, $\text{H}(1, 1, 1/2^+, 1.0078) = p$, $\text{H}(2, 1, 1^+, 2.0141) = \alpha$, etc., an assumption tacitly implemented hereon. Note that the preceding reaction verifies conventional nuclear conservation laws and can be engineered to verify all additional CNF laws.

The above synthesis is indeed of expected industrial relevance because the hourly rate of 10^{30} ICNF, a rather reasonable expectation due to the volume of available gas, would overcome the used energy and yield the hourly production of about 10^{10} BTU, namely, a rather significant new clean energy patterned along natural lighting.

Fusion (7.28) is more deeply interpreted as originating from the following two-steps process

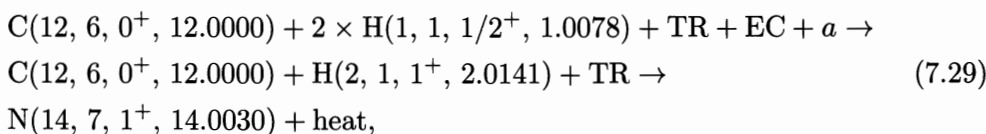

namely:

1) The electric arc first polarizes the carbon and hydrogen atoms by forming the magneucle $\text{C} \times \text{H} \times \text{H}$, including the necessary triplet axial coupling of spins.

2) Under a suitable trigger, the magneucle $\text{C} \times \text{H} \times \text{H}$ can only yield a nucleus with $A = 14$, $Z = 8$, $J^P = 1^+$ that is known not to exist (since $\text{O}(14, 8)$ has spin $J = 0$). The sole electron capture (EC) would also yield a nucleus known not to exist.

3) The explanation adopted by Santilli is that nature synthesizes the neutron from protons, electrons and etherinos according to the sequence:

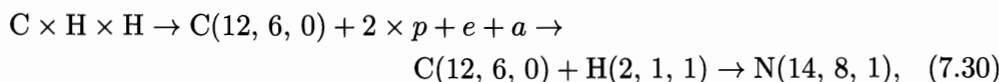

where we assume the correct spin couplings requested for ICNF. Another ICNF also suggested by lighting is given by

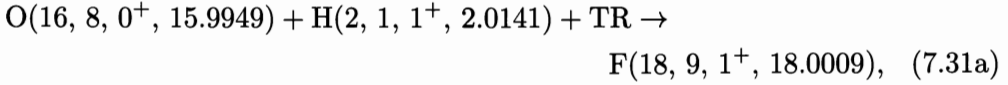

$$\Delta E = 0.0081 \text{ u} = 7.545 \text{ MeV}, \quad (7.31b)$$

and secondary process due to the instability of $\text{F}(18, 9, 1^+, 18.0009)$:

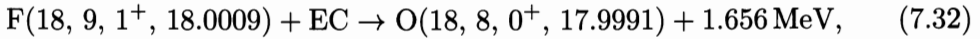

resulting in the following total energy output per synthesis

$$\Delta E = 9.201 \text{ MeV} \approx 1.30 \times 10^{-15} \text{ BTU}, \quad (7.33)$$

in which case, again, 10^{30} syntheses per hour would yield a rather substantial new clean energy.

An additional selection of hadronic fuel is a 50-50 mixture of deuteron and helium gases according to the following ICNF

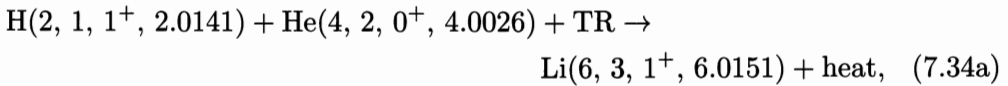

$$\Delta E = 0.0016 \text{ u} \approx 2.5 \times 10^{-16} \text{ BTU}, \quad (7.34b)$$

that verifies all CNF laws. Hence, one can see that a hadronic reactor with the above hadronic fuels becomes industrially relevant under the achievement of about 10^{30} CNF per hour, that would yield the hourly production rate of about 10^9 BTU.

Note the need, again, of deuterium for ICNF (7.31) and (7.34) and the need that deuterium be synthesized following the prior synthesis by lighting of the neutron. In turn, as the reader with serious interest in new knowledge will see, these aspects have a crucial relevance for the achievement of ICNF with industrially valuable energy output.

Another ICNF based on lithium is given by

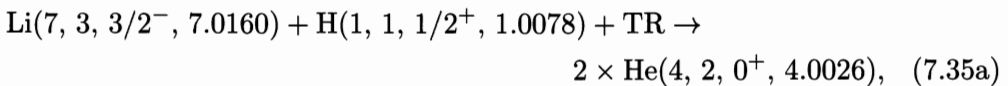

$$\Delta E = 2.887 \times 10^{-12} \text{ J}, \quad (7.35b)$$

where one should be aware of the opposing nuclear polarizations needed to verify the law on the conservation of the angular momentum, a feature of crucial

relevance for the engineering realization to have any hope of achieving industrial relevance.

The energy output of reactions (7.35) is significant. By using one mole of lithium that has 20^{23} nuclei; by assuming an efficiency of 10^{16} per minute; and by using energy units in Joules, we have the energy output

$$\Delta E = 2.8 \times 10^4 \text{ J/min} = 1.7 \times 10^6 \text{ J/h} \quad (7.36)$$

that is indeed industrially relevant.

At this point it is important to identify the rather dramatic differences, with negative environmental implications, between a number of studies via the "cold fusion" and the proposed ICNF. A typical reaction believed to be *necessary* for the "cold fusion" of two deuterium nuclei, is that into the tritium plus the emission of a neutron,

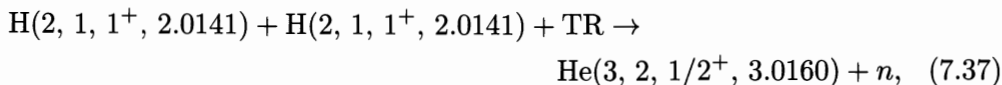

from which one can see the judgment on the existence of "cold fusion" of two deuterium nuclei on whether neutrons are emitted or not.

It is essential for the protection of the environment to show that the above criterion to appraise "cold fusions" is a pure theology if used as a basis to deny their existence. In fact, the belief is based on the need to conserve the total angular momentum that normally would yield the value $J = 2$ for the l.h.s of reaction (7.37). However, hadronic mechanics does indeed admit the synthesis of He-4 from two deuterium nuclei without any emission of massive radiation, yet via the appropriate use of deuterium nuclei with opposing polarizations according to the law

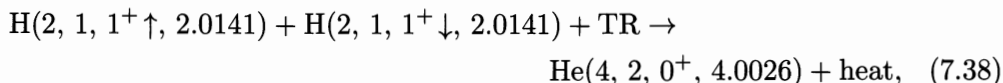

where one should keep in mind, again, the necessary spin couplings for the reaction to occur. The engineering realization of the latter reaction is studied in the next section.

At this stage we limit ourselves to indicate that *the denial* of nuclear syntheses based on the lack of neutron emissions is purely political and without serious scientific foundation, particularly when proffered by experts, because the latter are expected to know possibility (7.38) to qualify as such. It is at this point where problems of scientific ethics also emerge forcefully as a prerequisite for the solution of our serious environmental problems.

The difference between pre-existing studies on "cold fusion" and the proposed ICNF is also illustrated by the well known setting in which the reactor is filled

up with hydrogen, and the electrodes are made up of palladium 106. In these cases we should have fusions *inside the palladium cathode* of the type

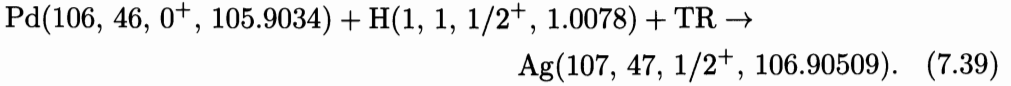

The above reactions do verify *conventional* nuclear conservation laws. However, the engineering implementation of the new CNF laws inside the palladium electrodes is virtually impossible, thus explaining the reason for the lack of consideration in the industrial research herein reported. The above occurrences also illustrates the viewpoint expressed from Section 1 to the effect that the author believes that nuclear fusions do indeed occur in setting of the type (7.39). However, they can at best be at random, thus precluding a serious hope to achieve the controlled energy output necessary for industrial relevance.

7.3.K *Engineering conception of hadronic reactors*

By using all the preceding advances, Santilli proposed specific and concrete engineering realizations of hadronic reactors first presented by in the 1999 monograph, then revised in the 2001 monograph and finalized in the 2008 memoir. We begin with a generic embodiment suitable for a variety of hadronic fuels, and then pass to more specific reactors with specific hadronic fuels.

Figure 7.13 presents a conceptual outline of a simple hadronic reactor in which the primary differences with the hadronic refineries of the preceding section are: refineries use a liquid feedstock, while reactors generally used a gaseous feedstock; refineries operate at generally low pressures of the order of 30 psi, while reactors need to operate at high pressures of the order of 3,000 psi or more to achieve industrial relevance due to the decrease of density of about 1,000 in the transition of the feedstock from a liquid to a gas; and reactors need heat exchangers much more efficient than refineries due to the decrease in heat propagation from liquids to gases.

In more engineering details with respect to Figure 7.14, from one of Santilli's we recall that the proposed hadronic reactor comprises: a metal vessel 232 with hemispherical heads 233, fasteners 252 and bases 234 capable of withstanding a pressure of at least 10,000 psi (666 bars); a stationary, negatively charged, anode 235 hat protrudes outside the hemispherical head 233 for connection via cable 299 to the negative polarity of a steady or pulsing AC-DC converter with at least 50 Kw power (not shown in the figure), said protrusion occurring through insulating pressure resistant bushing 236 in phenolic G10 or equivalent material; an internally movable, positively charged cathode 237 connected via cable 300 and insulating bushing 301 to the positive polarity of said outside power source; said cathode 237 being connected via insulating phenolic G10 block 238 to a metal rod equipped with rake 239 that is internally fastened to vessel 232 via

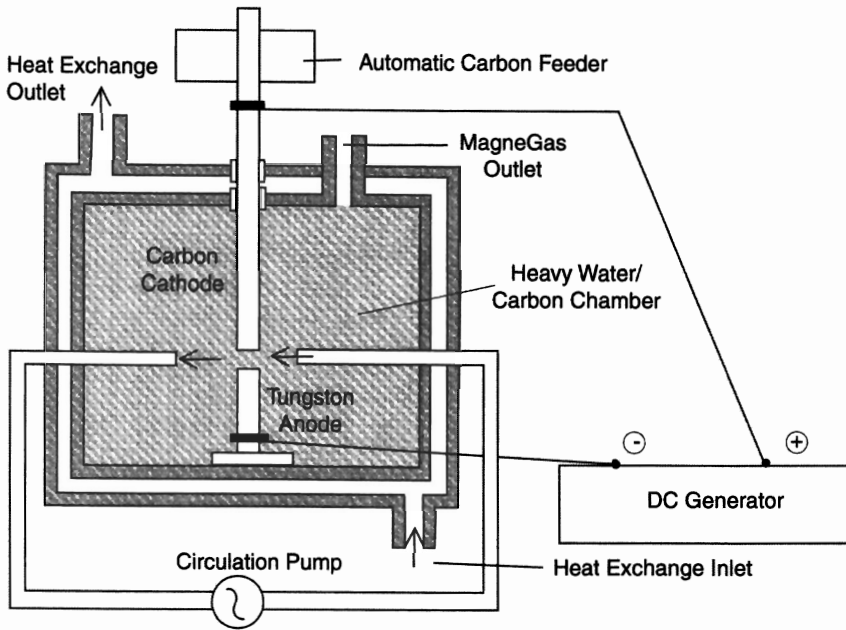

Figure 7.13. A schematic view of the Hadronic Reactor, essentially based on an engineering upgrade of the Hadronic Refineries of the preceding figures, showing the shift of emphasis, from the production and use of a magnequar fuel in the latter, to the production and use of heat in the former.

brackets 240; said rake 239 being operated by a pignon 240 that is controlled by an outside servomotor 242 through insulating pressure resistant thrust bearing 302; vessel 232 being filled up with a gaseous or liquid feedstock 251 that is recirculated through the electric arc 250 via pump 252 through pipe 253; the feedstock is then forced via pipe 244 for passage through heat exchanger 245 for continuous recirculation through the arc 250 via pump 252 and pipe 253; the heat acquired by heat exchanger 245 being utilized via an external fluid via inlet 246 and outlet 247; the proposed hadronic reactor being completed by pipe 248 for burst of pressure of the gaseous feedstock inside vessel 232 to realize the hadronic trigger, said burst of pressure being realized by outlet 260 and impact blower 261, check valves 262 protecting the primary pump 252 and the heat exchanger 245.

The operation of the proposed hadronic reactor is the following. Firstly, a vacuum inside vessel 232 is secured via valve 263. Subsequently, valve 263 is closed and the vessel is filled up with feedstock 251 via valve 264 up to the preset pressure of at least 5,000 psi (333 bars) for gases and up to 2/3 of the interior volume for liquids. Upon completion of the filling operation, the automatic controls activate the AC-DC converter and the primary pump 252 with the con-

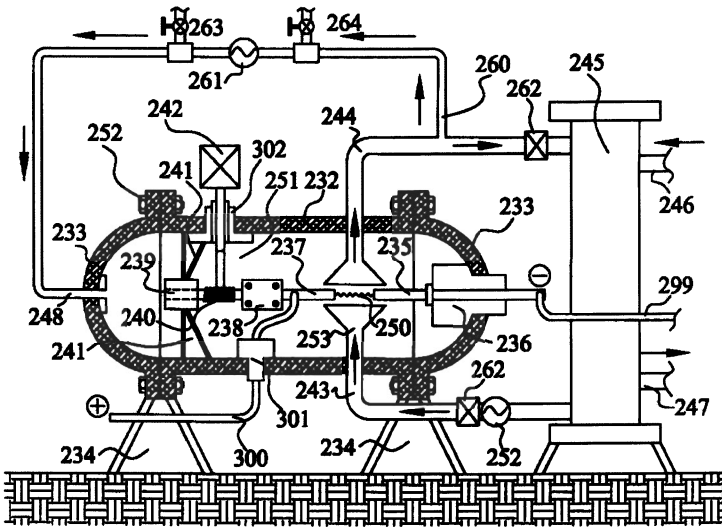

Figure 7.14. A more detailed view of a preferred embodiment for the industrial realization of hadronic reactors proposed for the industrial realization of ICNF.

tinuous recirculation of the feedstock through the arc. When the electrodes are at such a distance not allowing an arc for the pre-selected feedstock and for the pre-selected pressure (open arc), the automatic controls activate servomotor 242 acting on pignon 240 that activates rake 239 solidly connected to cathode 237 via insulating bushing 238, to move said cathode 237 toward the stationary anode 235 until such a distance at which an electric arc of high current (e.g., 1,000 A) within said feedstock is initiated. This first phase serves to create magnecules. The automatic controls then increase the gap between the electrodes to such a value for which the variation of the voltage is within preset values (one of the twenty adjustable parameters of the automatic controls of the Magnegas Technology www.magnegas.com), so as to maximize the voltage, or the gap between the electrodes, or the travel of the arc within the feedstock. Following a preset duration of such high current arc, the automatic control activate the high voltage impulse current as a partial realization of the trigger. According to a pre-set frequency, the automatic control also activate the impulse pump 261 to create burst of very high pressure inside vessel 232. This provides an engineering realization of the trigger via a combination of the following three means: 1) Impulse high voltage arcs; 2) Impulse high pressures; and 3) the enhancement of both preceding contributions by the arc geometry (Figure 7.8). It would be naive to assume that the above description is exhaustive, since numerous other features are needed to render the above hadronic reactor industrially viable. The author

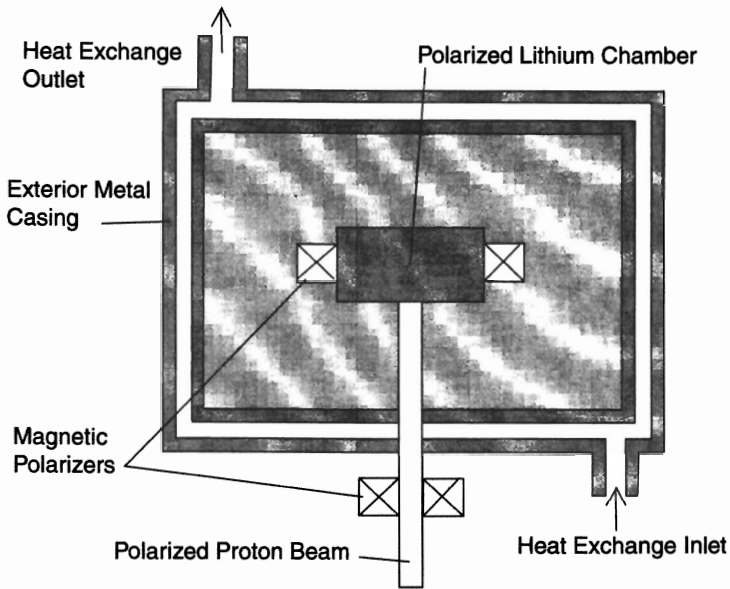

Figure 7.15. A schematic view of one of the simplest hadronic reactor, that for the synthesis of the lithium as per Eqs. (7.34).

regrets not to have received the necessary authorization by the investors for their disclosure at this writing.

1. Hadronic nitrogen reactor: The engineering realization of ICNF for reaction (7.28) is conceptually simple. It is given by a reactor with general lines depicted in Figure 7.13 and engineering realization studied in the next section. The metal vessel is filled up with deuterium gas at 3,000 psi pressure that is recirculated through graphite electrodes. The trigger is realized by pulse DC with 100,000 V and 5 mA and other means we are not authorized to disclose at this time. The heat is dissipated by the external heat exchanger.

2. Hadronic oxygen reactor: The engineering realization of ICNF (7.31) is, conceptually, one of the simplest because the reaction does not require spin polarizations for the conservation of the angular momentum. Hence, it is sufficient to use the embodiment conceptually outlined in Figure 7.13. The metal vessel is filled up with a 50-50 mixture of oxygen 16 and helium at 3,000 psi, which mixture is recirculated through a 50 Kw electric arc between carbon electrodes, thus creating magnecules of the type $O \times He$. The trigger can be given by DC pulses with 100,000 V and 5 mA, or by impulse pressures and other mechanisms. The heat produced is absorbed by the external all encompassing vessel and utilized via heat exchangers.

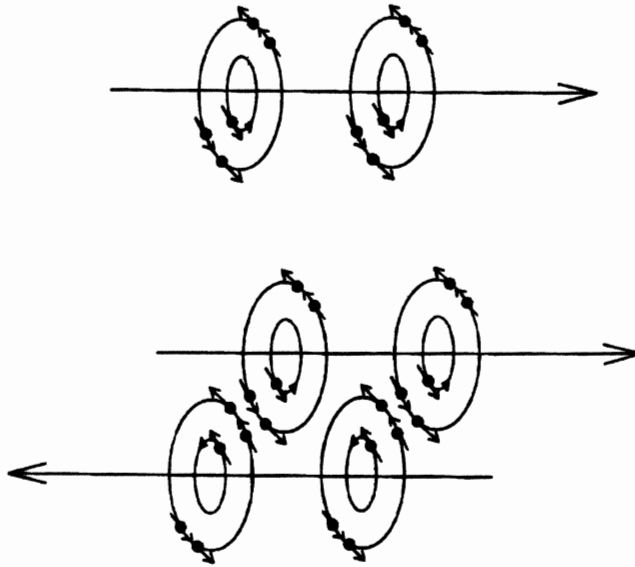

Figure 7.16. A schematic view of the singlet (antiparallel) spin coupling necessary to synthesize the helium from deuterium according to nuclear synthesis (7.38) which is of evident very difficult engineering realization for controlled systematic fusions.

3. First hadronic lithium reactor: The engineering realization of the first lithium reaction, Eq. (7.34), is essentially the same as that for the oxygen reactor, the only difference being that the vessel is filled up with a 50-50 mixture of hydrogen and helium gases also at 3,000 psi. The mixture is also recirculated through a 50 Kw electric arc that creates magnecules $H \times He$. The trigger can also be given by a high voltage pulse DC current or impulse pressure or other mechanism.

4. Second hadronic lithium reactor: The engineering realization of the second lithium reaction, Eq. (7.35), is more complex than the preceding one because of the need of lithium nuclei and a beam of protons with opposite polarization as a necessary condition to avoid a random reactions as occurring in "cold fusions". Current technology allows a variety of engineering realization of the needed polarization represented in Figure 7.16 where a proton beam with down polarization enters a chamber of lithium with up polarization, both polarizations being realized via magnetic fields. The efficiency of the hadronic reactor is then dependent on the geometry of both the proton beam and the lithium chamber plus an adequate trigger the author has not been authorized to disclose here at this time.

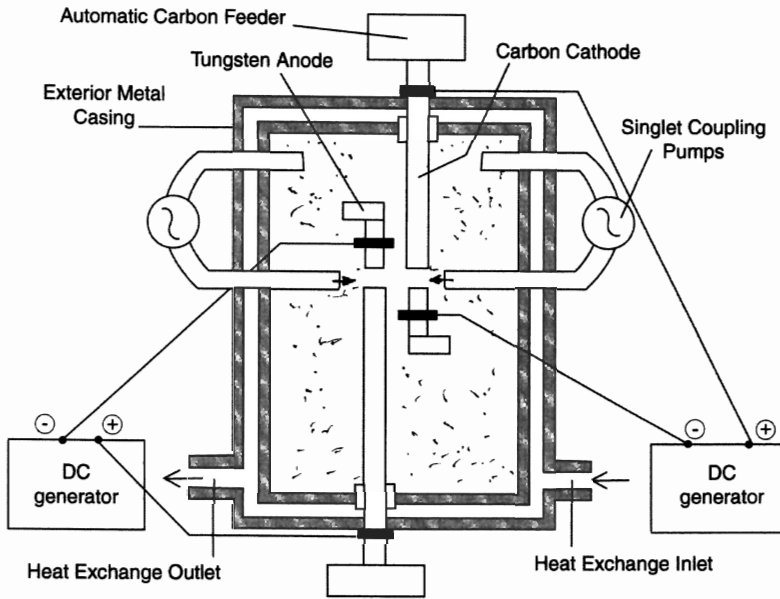

Figure 7.17. A schematic view of one of the most difficult hadronic reactors, that for the synthesis of the helium from two deuterium atoms with opposing polarization.

5. Hadronic helium reactor: The engineering realization of reaction (7.38) is one of the most difficult because it requires the application of a trigger to two beams of deuterium gas with opposite spin polarizations. The main idea expressed in the embodiment of Figure 7.17 is that of a metal vessel as in the preceding reactors that houses two parallel but separate electric arcs with opposing polarities so as to produce opposite polarizations of said deuterium gas. The flow of the gas through said arcs from opposite directions then creates the superposition of said beams in the area located between said arcs with spin couplings depicted in Figure 7.17. In this case the trigger may be given by impulse pressure or other means.

7.3.L *Experimental verification of nitrogen synthesis without harmful radiations or waste*

7.3.L.A **Experimental set up**

In this section, we review Santilli's 2010 paper presenting one of the most important experimental verifications of the entire mathematical, physical and chemical research studied in this volume, verification conducted in early 2010 at the laboratory of the *The Institute for Basic Research (IBR)* in Tarpon Springs,

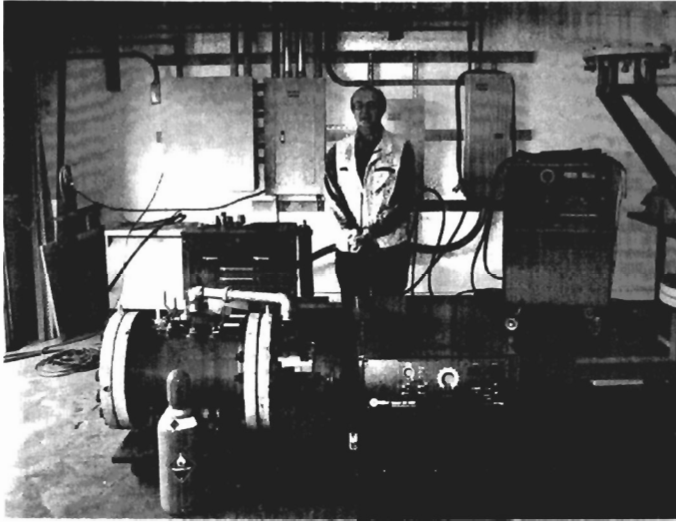

Figure 7.18. A view of Prof. Santilli with the equipment used for the synthesis of nitrogen from carbon and deuterium showing from the r.h.s.: the Miller Dimension 1000 AC-DC converter; the pressure bottle of 99.99 pure deuterium; and the 12" × 24" schedule 80 hadronic reactor.

Florida, and consisting of the apparently first achievement, per our knowledge, of *the nuclear synthesis of nitrogen from carbon and deuterium without any release of harmful radiation or radioactive waste, according to reactions (7.28).*

With reference to Figure 7.18, Santilli constructed in early 2009 a hadronic reactor consisting of a 12" diameter and 24" long Schedule 80 carbon steel pipe with related flanges, tested at 300 psi so as to safely operate at 150 psi pressure, equipped with internal electrodes composed of commercial grade graphite, the anode being stationary and the position of the cathode being controllable from the outside via a suitable insulated knob allowing the initiation and disconnection of the arc, said reactor being completed by inlet and outlet gaseous ports, pressure and other gauges.

Radiation counts during the test were done via the following detectors placed next to the hadronic reactor:

- 1) A photon-neutron detector model PM1703GN manufactured by *Polimaster, Inc.*, with sonic and vibration alarms as well as memory for printouts, with the photon channel activated by CsI and the neutron channel activated by LiI;
- 2) A photon-neutron detector SAM 935 sold by *Berkeley Nucleonics, Inc.*, with the photon channel activated by NaI and the neutron channel activated by He-3 also equipped with sonic alarm and memory for printouts of all counts;
- 3) A BF^3 activated neutron detector model 12-4 manufactured by *Ludlum Measurements, Inc.*, without counts memory for printouts but with both visual and sonic means;

- 4) An alpha, beta, gamma and X-ray detector model 907-palmRAD sold by *Berkeley Nucleonics, Inc.*; and
- 5) Various material suitable for nuclear transmutations.

7.3.L.B Conduction of the tests

On January 7 2010, a vacuum was first pulled out of said reactor by IBR technicians Gene West and Michael Rodriguez who subsequently filled up the reactor up to 100 psi with deuterium gas 99.99% pure as certified and supplied by *Advanced Special Gases* of Reno, Nevada. The original deuterium tank was then disconnected. A two-valves laboratory bottle market HT1 was then filled up for chemical analysis with the gas in the interior of the reactor, thus including the original deuterium plus internal impurities. Commercially available digital sensors were used for the recording of temperatures, pressures, times and other data.

No PlasmaArcFlow of the deuterium gas through the arc was activated because the first reactor here referred to did not have a cooling system and, in its absence, operations had to be stopped in one or two minutes due to excessive production of heat. Also, the experiment was intended solely to establish the *existence* of nuclear synthesis (7.28) with the absence of harmful radiation or waste, since the achievement of a large scale production of energy requires basically different approaches and vast development funds in due time.

Still, with reference to Figure 7.18, the electrode terminals of the reactor were connected to a commercially available Miller Electric Dimension 1000 AC-DC converter set to operate at 40 Kwh. Gene West and Michael Rodriguez activated the DC electric arc in the interior of the reactor for two minutes, after which time the arc had to be disconnected because the reactor, originally at about 20°C and 100 psi, had reached well over 150°C and 200 psi, with the external paint showing signs of scorching.

A second two-valves laboratory bottle was marked HT2 and filled up with the gas in the interior of the reactor following the activation of the arc due flushing. Under the trail of custody by the IBR technician Jim Alban, the two laboratory bottles so obtained were shipped to *ORS Oneida Research Services* of Whiteboard, New York, for analyses.

7.3.L.C Experimental results

The first and perhaps most important feature reported in the 2010 paper, under the eye witnessing of Gene West, Michael Rodriguez and Jim Alban, is the absence of any massive radiations in the outside of of the hadronic reactor, with particular reference to the absence of any detection of neutrons that, in case produced, are predicted to be detectable in the outside.

Repeated tests of the interior of the reactor following the tests showed complete absence of any radioactive waste. Internally produced charged particles are easily absorbed by the thick Schedule 80 metal walls of the reactor and cannot be detected in the outside. In any case, no production of neutrons, protons or alpha particles is possible due to insufficient energies for the fission of light stable nuclei.

The analyses on samples HT1 and HT2 were conducted by ORS Oneida Research Services, via an Internal Vapor Analyzer, model 110-s which is the latest version of the system. The analyses were performed per ORS SOP MEL-1070, Gas Analysis of Sealing Chamber Atmosphere. The main results are shown in Figure 7.19.

The most significant measurements (see Figure 7.19) are the *decrease* of the deuterium gas in two minutes of operation from 93.3% to 91.8% and the *increase* of nitrogen has from 4.90% to 6.11%, thus providing experimental confirmation of the nitrogen synthesis (7.28) as predicted in the 2008 memoir.

Heat measurements were done as follows. The reactor essentially consisted of a schedule 80 pipe 1 ft diameter and 2 ft long, with two hollow flanges welded at its ends. According to tabulated data (verified with approximate but actual measurements), the weight of this assembly is of 325 lbs plus the weight of the steel in the four (two external and two internal) weldings. To be conservative, Santilli assume that the weight of this assembly, hereon referred to as the “cylindrical component,” is of 300 lbs.

Additionally, the reactor comprises two plain flanges each having a tabulated (and approximately but actually verified) weight of 189 lbs. However, these flanges are thermally isolated from the cylindrical component to a great extent due to the gaskets between the plain flanges and the cylindrical component. In fact, systematic heat measurements showed that the cylindrical component would acquire heat much faster and in much greater amount than the terminal flanges.

Consequently, the heat measurements were solely referred to the cylindrical component. The measurements on the terminal flanges were deferred to future independent verifications since, as indicated above, the primary objective of the 2010 paper is to ascertain the existence of ICNF, and not their industrial output.

As also indicated earlier, the tests on deuterium gas at 100 psi with a 40 kW arc between carbon electrodes operated for two minutes showed a systematic increase in temperature, from the ambient temperature in the range of 20°C to generally over 150°C with a conservative average increase of about 127°C. The use of the known expressions

$$\frac{449 \text{ J/kg C} \times 136.077 \text{ kg} \times 127 \text{ C}}{1055.06 \text{ J/BTU}}$$

yields the heat acquired by the cylindrical component (cc)

$$\Delta E_{cc} = 7404 \text{ BTU}, \quad (7.40)$$

TEST REPORT | INTERNAL VAPOR ANALYSIS

Page 1 of 1
 ORS LOT NO 184443-001
 DATE TESTED 1/18/2010
 QUANTITY TESTED 2
 PACKAGE TYPE CYLINDER
 MFG CODE Date filled: 01/14/10
 Filled by: R.S.
 PO: XXXX-XXXX-XXXX-7641
 Rel. No:
 RUGGERO SANTILLO
 INSTITUTE FOR BASIC RESEARCH

720 WESLEY AVE
 SUITE #1
 TARPON SPRINGS, FL 34689
 UNITED STATES

SAMPLE ID		HT1	HT2
INLET PRESSURE	torr	219	333
NITROGEN	ppmv	49042	61085
OXYGEN	ppmv	13254	3211
ARGON	ppmv	542	592
CO2	ppmv	ND	497
MOISTURE	ppmv	402	10705
HYDROGEN	ppmv	3321	3937
METHANE	ppmv	ND	ND
AMMONIA	ppmv	ND	ND
DEUTERIUM	ppmv	933379	917980
FLUOROCARBONS	ppmv	ND	ND π
BENZENE	ppmv	60	ND
UNKNOWN*	ppmv	ND	1993

COMMENTS:

Tested per ORS SOP MEL-1070: Gas Analysis of Sealing Chamber Atmosphere.
 Mass 3 was not quantitated but is shown in the spectra report.

APPROVED BY: Daniel J. Rossiter

Figure 7.19. A view of the the results of the analysis of samples HT1 and HT2 by ORS Oneida Research Services showing a clean increase of nitrogen counts combined with a clean decrease of deuterium counts.

By recalling the known value 1 Kwh = 3400 BTU, the use of 40 Kwh for two minutes yields

$$\Delta E_{\text{arc}} = 4533 \text{ BTU.} \quad (7.41)$$

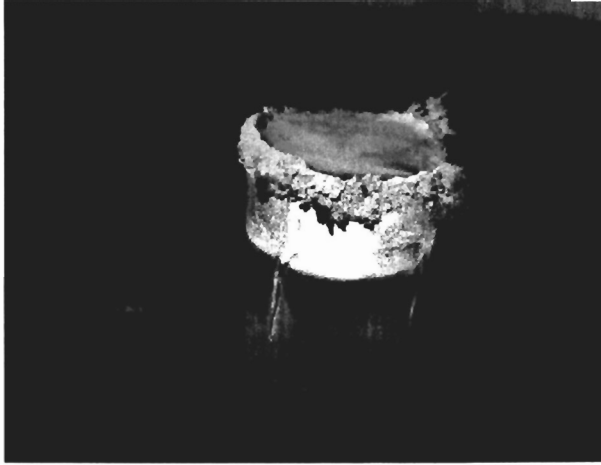

Figure 7.20. A view of the carbon electrodes following one of the tests reported below, whose whitish scorching is visual evidence of nuclear fusions since the tests dealt with a pure deuterium gas without oxygen, thus without any combustion at all, and the scorching cannot possibly have done by the arc alone.

Consequently, the nuclear syntheses in the interior of the reactor yielded in two minutes the excess heat of

$$\Delta E_{\text{out}} = 2871 \text{ BTU}, \quad (7.42)$$

by keeping in mind that Santilli did not considered the heat acquitted by the isolated side flanges. Consequently, the actual value of the excess heat is bigger than the above, thus confirming the existence of a significant internal source of energy beyond that of the AC-DC converter.

Recall that a vacuum was pulled out of the reactor, that was then filled with 99.99% pure deuterium gas which, prior to the test, measured 93.3%, the residual gases being noncombustible except for traces of oxygen. Consequently, *the excess energy release cannot possibly be attributed to internal combustion since the deuterium gas is not combustible when alone. Hence, the sole credible interpretation is that the excess energy is due to nuclear fusions.*

Additionally, the reactor was opened after each tests and observation showed systematic scorching of the electrodes to such a degree that cannot possibly be explained via the sole heat produced by the electric arc due to the above indicated absence of combustion (see Figure 7.20).

7.3.L.D Tests with deuterium and tungsten electrodes

In order to confirm whether or not the excess heat is specific for the combination of deuterium gas traversed by a DC arc between carbon electrodes, the author conducted systematic measurements by replacing the carbon electrodes

with electrodes fabricated from commercially available tungsten and the use of a number of different gases.

It is important to report that, *under the same conditions of pressure, power, duration, etc., as those of the preceding tests, the operation of the hadronic reactor with gases composed by commercially available hydrogen and air traversed by a 40 kW DC arc between tungsten electrodes produced no appreciable energy excess.*

7.3.L.E Tests with air and tungsten electrodes

For comparative purposes, Santilli then conducted tests with the same equipment as above but with the reactor filled up with air and operating with tungsten electrodes. In this case Santilli measured the transition in two minutes in the cylindrical component of the reactor, from the ambient temperature of about 20°C to about 60°C, thus showing a temperature increase of about 40°C compared to the average temperature increase of the tests of the preceding section of about 127°C.

This result is, perhaps, the most important confirmation of the preceding nitrogen synthesis, because it illustrates the crucial role of carbon for the ICNF here reported.

7.3.L.F Tests with hydrogen and carbon electrodes

Santilli also conducted systematic tests to achieve ICNF via the use of the same equipment as per preceding tests, but filled up with hydrogen instead of deuterium gas and use of carbon electrodes.

Among a number of tests conducted by Santilli from January 2009 to February 2010, we report a test done on February 9, 2010 in which a vacuum was pulled out of the hadronic reactor of Figure 7.18, that was filled up with commercial grade hydrogen at 100 psi pressure; a sample of the gaseous content of the reactor was taken and market HCN1 for analysis; the reactor was then operated for two minutes under 40 Kw DC; a new sample of the gas content was taken and market HCN2 for analysis; the two samples were then shipped via FedEx Next Day Air to Oneida Research Laboratories for analysis; and some of the results are presented in Figure 7.21.

The important result of this test is that *under the same conditions of pressure, power, electrodes, etc., the operation with hydrogen gas produced an energy excess bigger than that with deuterium gas, since in two minutes the temperature of the reactor increased of about 50% over the test with deuterium.*

The increased energy output was predicted in the 2008 memoir due to much broader possibilities of ICNF. In fact, the analysis of Figure 7.21 shows that nitrogen (at 28 amu has indeed increased from 24,684 to 30,171 counts. However, we additionally have: the species at 4 amu increased from ND to 76 counts; the species at 14 amu increased from 2,841 to 3,555 counts; the species at 15 amu



8282 HALSEY ROAD • WHITESBORO, NY 13492 • PHONE: (315) 736-5480

**SPECTRA REPORT
INTERNAL VAPOR ANALYSIS**

 RUGGERO SANTILLO
 INSTITUTE FOR BASIC RESEARCH
 150 RAINVILLE ROAD
 34689 TARPON SPRINGS FL
 UNITED STATES

 ORS JOB NO. : 184727-001
 DATE TESTED : 2/12/2010
 QUANTITY TESTED : 2
 PACKAGE TYPE : CYLINDERS
 MFG. CODE : Date filled: 2/10/10

PO: HTI-10-44-83654

Filled by: Gene West

Rel. No:

SAMPLE ID	HCN1	HCN1						
AMU 2	16,075,402	18,550,801						
AMU 3	30,269	41,165						
AMU 4	-	76						
AMU 12	33	31						
AMU 14	2,841	3,555						
AMU 15	116	278						
AMU 16	1,205	3,010						
AMU 17	1,097	2,489						
AMU 18	2,718	2,949						
AMU 27	100	90						
AMU 28	24,684	30,171						
AMU 29	532	736						
AMU 30	66	81						
AMU 32	5,300	6,621						
AMU 40	272	366						
AMU 44	180	190						

COMMENTS:

Tested per ORS SOP MEL-1070: Gas Analysis of Sealing Chamber Atmosphere.
 Mass 3 was not quantitated but is shown in the spectra report.

Figure 7.21. A view of the the results of the analysis of samples HCN1 and HCN2 by ORS Oneida Research Services.

increased from 116 to 378 counts; the species at 16 amu increased from 1,205 to 2,948 counts; etc.

Consequently the measurements here reported provide experimental confirmation, not only of the synthesis of the nitrogen from hydrogen and carbon via the intermediate synthesis of the deuterium according to reactions (2.29), but also the synthesis of the oxygen, as well as other nuclear syntheses.

7.3.L.G Tests with magnegas and carbon electrodes

By still following Santilli 2010 paper, we here report that the repetition of the preceding tests via the use of the magnegas (MG) and carbon electrodes produced an energy output bigger than that of all the preceding cases.

The tests were done on November 28, 2009 by filling up the hadronic reactor of Figure 7.18 with magnegas after pulling out a vacuum and a sample bottle was taken market MG1 for analysis; the reactor was operated for one minute and a second sample bottle was taken market MG2 for analysis; the two bottles were then sent to ORS Oneida Research Laboratory for analysis via next day delivery, with results are partially reported in Figures 7.22.

On a comparative basis with preceding tests, the most significant result is that the reactor had to be stopped after only one minute of operation, rather than the two minutes of operation of the preceding tests, to avoid damage due to excess heat not being dissipated.

This result was also predicted in the 2008 memoir because the acquisition of a magnecular structure is necessary for the ICNF here considered since said structure is necessary for the exposure of nuclei and their proper spin alignment. In the preceding tests, the deuterium and hydrogen gases did not originally have any magnecular structure that, therefore, had to be created by the arc prior to possible nuclear fusions. It is then evident that the conduction of the same tests with a gas already possessing a magnecular structure must have a bigger efficiency and energy output.

The test was repeated in the same day with hydrogen, and two samples were taken market HC1 and HC2 for analyses, one before and the other after activation of the arc. The results of their analysis are combined with those for magnegas in Figures 7.22 for confirmation of the preceding results.

In Figure 7.23 we report analyses on the repetition of the hydrogen tests exactly as done previously, with the sole difference that the electrodes were given by tungsten, rather than carbon rods. The tests were repeated twice in succession, resulting in the two sets of two samples of Figure 7.23, the first and third columns presenting commercial grade hydrogen with the contaminants contained in the reactor due to preceding tests, while the second and fourth columns present the data on the preceding samples after activation of the arc for two minutes.

The important result is the definite increase of the species with 3 amu from 23,638 to 27,078 counts for the first set and from 58,537 to 66,427 counts for the second set of samples. Evidently, *these systematic increases confirm the laboratory synthesis of the neutron from a hydrogen gas studied in Chapter 6.* The neutron is then captured by the hydrogen molecule, by increasing in this way its weight to 3 amu apparently for a yet unexplored capability of electric arcs to attract polarized particles toward its symmetry axis. As indicated earlier,



8282 HALSEY ROAD • WHITESBORO, NY 13492 • PHONE: (315) 736-5480

**SPECTRA REPORT
INTERNAL VAPOR ANALYSIS**

 RUGGERO SANTILLO
 INSTITUTE FOR BASIC RESEARCH
 720 WESLEY AVE
 SUITE #1
 34689 TARPON SPRINGS FL
 UNITED STATES

 ORS JOB NO. : 183831-001
 DATE TESTED : 11/12/2009
 QUANTITY TESTED : 4
 PACKAGE TYPE : CYLINDERS
 MFG. CODE : Date filled: 1-1-09

 PO: XXXX-XXXX-XXXX-7641
 Rel. No:

Filled by: Gene West

SAMPLE ID	EQ09016	EQ09016	EQ09018	EQ09018				
AMU 2	10,710,660	11,454,640	11,579,230	11,934,680				
AMU 3	23,628	27,078	58,537	66,427				
AMU 12	37	38	86	87				
AMU 13	-	-	18	18				
AMU 14	3,075	3,376	2,673	2,812				
AMU 15	92	183	369	413				
AMU 16	1,375	2,337	1,425	1,772				
AMU 17	5,668	7,648	12,305	12,866				
AMU 18	19,338	20,219	46,144	45,938				
AMU 19	56	55	290	324				
AMU 20	66	-	72	90				
AMU 27	-	-	84	55				
AMU 28	26,085	27,706	18,213	18,386				
AMU 29	646	713	926	1,038				
AMU 30	221	200	114	101				
AMU 32	5,250	5,580	-	-				
AMU 40	316	360	220	240				
AMU 44	257	295	361	326				
AMU 78	-	-	164	189				

COMMENTS:

 Tested per ORS SOP MEL-1070: Gas Analysis of Sealing Chamber Atmosphere.
 UNKNOWN*: Unidentified organic compound(s).
 UNKNOWN spectra may be Benzene.

Figure 7.22. A view of the the results of the analysis of two sets of two identical samples obtained before and after the activation of the DC arc on tungsten (rather than carbon) electrodes.

this synthesis is crucial for subsequent ICNF in a way similar to what is the case in the Stars.

7.3.L.H Experimental confirmation of Santilli magnecules

Experts in quantum chemistry, but without a technical knowledge of the covering hadronic chemistry [18], may be confused by the inspection of the analytic measurements due to the presence of anomalous chemical species, i.e., species



8282 HALSEY ROAD • WHITESBORO, NY 13492 • PHONE: (315) 736-5480

**SPECTRA REPORT
INTERNAL VAPOR ANALYSIS**

RUGGERO SANTILLO
INSTITUTE FOR BASIC RESEARCH
720 WESLEY AVE
SUITE #1
34689 TARPON SPRINGS FL
UNITED STATES

ORS JOB NO. : 184033-001
DATE TESTED : 12/3/2009
QUANTITY TESTED : 4
PACKAGE TYPE : CYLINDERS
MFG. CODE : Date filled: 12-2-09

PO: XXXX-XXXX-XXXX-7641
Rel. No:

SAMPLE ID	HC1	HC2	MG1	MG2				
AMU 2	19,247,560	17,401,980	5,856,860	6,199,590				
AMU 3	124,952	100,326	13,153	14,740				
AMU 4	74	68	3,515	3,708				
AMU 6	-	-	623	663				
AMU 11	-	-	157	131				
AMU 12	158	5,783	170,042	180,955				
AMU 13	43	12,223	95,753	102,621				
AMU 14	5,575	28,847	183,460	200,608				
AMU 15	439	148,998	932,097	1,025,447				
AMU 16	3,621	170,812	1,102,872	1,209,096				
AMU 17	9,146	12,454	25,515	26,046				
AMU 18	27,751	32,087	23,935	21,142				
AMU 19	252	269	742	738				
AMU 20	139	115	-	-				
AMU 22	-	-	1,379	1,440				
AMU 24	-	1,147	23,544	23,635				
AMU 25	-	4,381	84,937	84,755				
AMU 26	250	24,314	439,169	438,430				
AMU 27	497	18,353	219,214	232,044				
AMU 28	42,692	94,667	2,620,060	2,752,030				
AMU 29	3,362	8,868	92,706	99,472				
AMU 30	111	6,102	38,497	41,798				
AMU 31	62	195	2,323	2,564				
AMU 32	13,766	6,778	4,150	1,582				
AMU 33	123	-	114	113				
AMU 36	-	-	1,360	1,368				
AMU 37	-	-	7,727	8,150				
AMU 38	-	92	10,563	10,967				
AMU 39	170	335	39,221	41,043				
AMU 40	690	543	13,582	13,199				
AMU 41	300	241	24,509	24,867				
AMU 42	-	-	11,591	11,871				
AMU 43	-	-	2,546	2,585				
AMU 44	642	1,272	140,842	146,039				
AMU 45	-	-	3,027	3,142				

COMMENTS:

tested per ORS SOP MEL-1070: Gas Analysis of Sealing Chamber Atmosphere.

Figure 7.23. A view of the the results of the analysis of samples HC1-HC2 and MG1-MG2 by ORS Oneida Research Services.

that are generally unknown, such as the species at 6 amu, the species at 19 amu (called by Santilli H₃O with structure

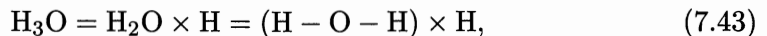



**SPECTRA REPORT
INTERNAL VAPOR ANALYSIS**

8282 HALSEY ROAD • WHITESBORO, NY 13492 • PHONE: (315) 736-5480

RUGGERO SANTILLO
INSTITUTE FOR BASIC RESEARCH
720 WESLEY AVE
SUITE #1
34689 TARPON SPRINGS FL
UNITED STATES

ORS JOB NO. : 184033-001
DATE TESTED : 12/3/2009
QUANTITY TESTED : 4
PACKAGE TYPE : CYLINDERS
MFG. CODE : Date filled: 12-2-09

PO: XXXX-XXXX-XXXX-7641
Rel. No:

SAMPLE ID	HC1	HC2	MG1	MG2				
AMU 46	-	-	653	703				
AMU 48	-	-	607	602				
AMU 49	-	-	3,812	3,806				
AMU 50	-	196	16,967	17,718				
AMU 51	-	201	16,262	17,135				
AMU 52	-	169	15,373	16,131				
AMU 53	-	-	5,503	5,673				
AMU 54	-	-	5,723	5,802				
AMU 55	-	-	2,538	2,658				
AMU 56	-	-	2,753	2,812				
AMU 57	-	-	226	239				
AMU 58	-	-	250	248				
AMU 59	-	-	145	-				
AMU 60	-	-	382	395				
AMU 61	-	-	679	763				
AMU 62	-	-	905	1,018				
AMU 63	-	-	2,647	2,953				
AMU 64	-	-	262	310				
AMU 65	-	-	2,660	2,848				
AMU 66	-	-	3,474	3,766				
AMU 67	-	-	1,846	1,853				
AMU 68	-	-	684	670				
AMU 69	-	-	208	185				
AMU 70	-	-	327	348				
AMU 72	-	-	84	88				
AMU 73	-	-	934	1,008				
AMU 74	-	-	2,707	2,925				
AMU 75	-	-	977	1,065				
AMU 76	-	156	2,558	2,825				
AMU 77	-	153	12,308	13,170				
AMU 78	131	697	50,466	55,332				
AMU 79	-	-	4,426	4,766				
AMU 80	-	-	568	606				
AMU 81	-	-	135	135				
AMU 82	-	-	117	130				

COMMENTS:

Tested per ORS SOP MEL-1070: Gas Analysis of Sealing Chamber Atmosphere.
Mass 3 was not quantitated but is shown in the Soectra Report.

Figure 7.23 (continued).

and numerous others (see Chapter 4).



**SPECTRA REPORT
INTERNAL VAPOR ANALYSIS**

8282 HALSEY ROAD • WHITESBORO, NY 13492 • PHONE: (315) 736-5480

RUGGERO SANTILLO
INSTITUTE FOR BASIC RESEARCH
720 WESLEY AVE
SUITE #1
34689 TARPON SPRINGS FL
UNITED STATES

ORS JOB NO. : 184033-001
DATE TESTED : 12/3/2009
QUANTITY TESTED : 4
PACKAGE TYPE : CYLINDERS
MFG. CODE : Date filled: 12-2-09

PO: XXXX-XXXX-XXXX-7641
Rel. No:

SAMPLE ID	HC1	HC2	MG1	MG2				
AMU 84	-	-	177	191				
AMU 89	-	-	145	168				
AMU 91	-	-	2,912	3,168				
AMU 92	-	-	1,523	1,703				
AMU 93	-	-	130	150				
AMU 102	-	-	79	89				
AMU 103	-	-	201	236				
AMU 104	-	-	426	445				
AMU 105	-	-	90	97				
AMU 106	-	-	115	108				
AMU 115	-	-	82	141				
AMU 116	-	-	-	117				
AMU 128	-	-	-	77				

COMMENTS:

tested per ORS SOP MEL-1070: Gas Analysis of Sealing Chamber Atmosphere.
mass 3 was not quantitated but is shown in the Spectra Report.

Figure 7.23 (continued).

Anomalous species of the above type are generally interpreted in the orthodox chemical literature as being “fragments” of heavier molecules, thus maintaining the dominance of the valence bonds in the interpretation of analytic results.

However, such a conventional interpretation cannot be credibly applied to the analytic results presented by Santilli in his 2010 paper for the very simple reason that the original gas was very light, such as hydrogen, and then merely subjected

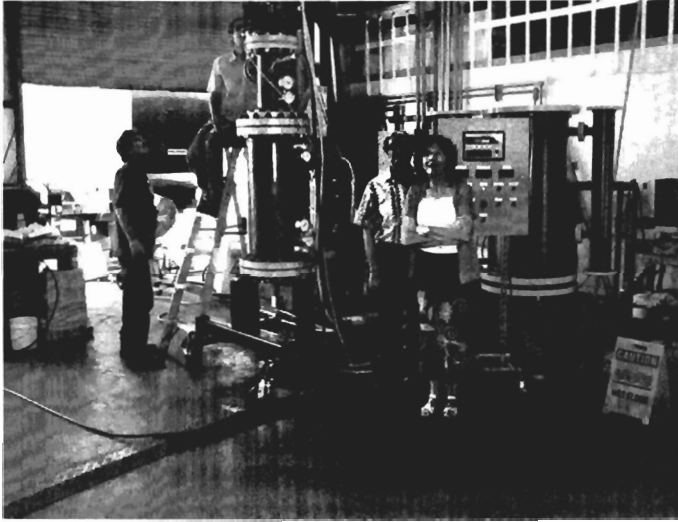

Figure 7.24. A view of Prof. and Mrs. Santilli while supervising the construction of a larger hadronic reactor for the initiation of industrial research on the ICNF (Spring 2010).

to the DC arc. In fact, the latter is known not to be able to create conventional molecular species, thus leaving as the sole most plausible interpretation of the anomalous species as being composed by Santilli magnecules.

7.3.L.I Dismissal of hydrogen as hadronic fuel

Being an environmental scientist, Santilli has spent years of research in hydrogen technologies. He does indeed supports the use of hydrogen as automotive fuel, but provided that hydrogen is produced with electrolytic processes via the use of clean renewable electric energy (such as that of solar or wind origin), and the produced oxygen is released in the atmosphere, for recombination with hydrogen at the type of combustion as a condition to maintain the current oxygen balance in our atmosphere.

However, Santilli has repeatedly expressed in his writing cautions against the widespread use of hydrogen as automotive fuel in its current form of production (via the use of non-renewable electric energy and the use of the separated oxygen) because of serious environmental problems, such as:

- 1) The *oxygen depletion*, referred to the permanent removal of breathable oxygen from our atmosphere and its conversion into H_2O whose separation to restore the original oxygen balance in our atmosphere is too costly. By comparison, gasoline produces CO_2 which is recycled by plants into O_2 . Additionally, CO_2 is still contained in our atmosphere in a rather small percentage (less than 1%), while our atmosphere contains water in large amounts (e.g., up to 90% in Florida), thus

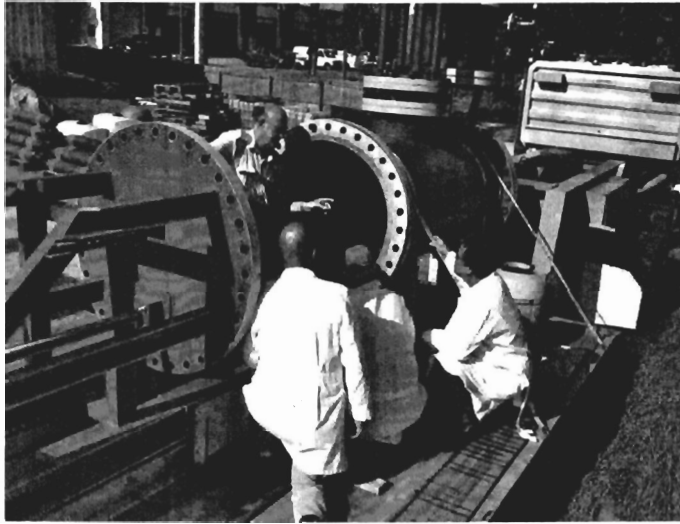
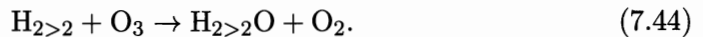

Figure 7.25. A view of Prof. Santilli and IBR technicians while discussing the construction of a large industrial hadronic reactor (Summer 2010).

preventing any appreciable recycling of water into oxygen by plants. These are the reason mankind has survived the ongoing disproportionate use of fossil fuels. By comparison, it has been shown that, in the event the industrial revolution had occurred via the use of hydrogen as automotive fuel, humanity would have been extinct because of excessive depletion of breathable oxygen below the level necessary to sustain human life.

2) The *ozone depletion*, referred to the permanent loss of ozone due to hydrogen seepage and its rapid raising to the ozone layer with resulting very rapid reaction



3) The need of liquefy hydrogen and maintain it as such,, which is necessary for hydrogen to have any appreciable automotive range, with serious risks in the event of a malfunction of the cooling system;

4) The pollution created by the current means for hydrogen production, such as in the reformation of fossil fuel such as methane $\text{CH}_{2>4}$; releasing vast amounts of green house gases $\text{CO}_{2>2}$;

5) The well known problem called *embrittlement* that render steel pressure bottle prone to explosion, and other problems.

Additionally, Santilli strongly discourages the use of hydrogen as hadronic fuel, that is, as fuels for his ICNF for the evident reason that its use implies the necessary synthesis of neutrons as studied in detail in the preceding section.

In conclusions, Santilli recommends in his 2010 paper the selection of any desired hadronic fuel under the indicated priority of not releasing harmful radiations

and/or radioactive wastes. These conditions inevitably focus the attention on the hadronic fuels selected by Santilli, namely, the ICNF of light, natural and stable elements into light, natural and stable element.

7.3.M Independent verification of Santilli's nitrogen synthesis without harmful radiation or waste

7.3.M.A Foreword

We now review the paper [200] by R. Brenna, T. Kuliczowski and L. Ying. The above identified experimentalists under the leadership of Leong Ying spent one week in mid March 2010 at the laboratory of *The Institute for Basic Research* in Tarpon Springs, Florida, for the specific purpose of independently confirming or denying Santilli's measurements presented in the preceding section.

For this purpose, said experimentalists had to use exactly the same experimental set up as used by Santilli so as to avoid the risk of running the same experiments. Santilli did not participate to the measurements, but the IBR technicians G. West, M. Rodriguez, J. Alban and others assisted L. Ying and his associates in the exact repetition of the synthesis of nitrogen from a deuterium gas and carbon electrodes as outlined in Section 7.3L.

Following expensive and repeated measurements, the experimentalists confirm both the experimental detection of magneuclear clusters as well as the nitrogen synthesis by reaching the following conclusion:

The results taken from the experimental runs conducted on the hadronic reactor indicates some form of exothermal reaction taking place that produced clusters of higher mass components. Since chemical reactions and combustion cannot have occurred in a pure deuterium environment, the conclusion leads to an indication of the process described as Intermediate Controlled Nuclear Fusion without harmful radiations.

7.3.M.B Deuterium-carbon fusion

The above important verification can be summarized as follows. The objective was the study of Santilli's ICNF of deuterium and carbon by the ICNF process to form nitrogen, which can be described using hadronic mechanics with the following reaction in the symbols identified above

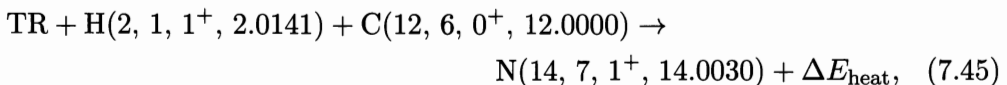

$$\Delta E_{\text{heat}} = 0.0111 \text{ amu} = 10.339 \text{ MeV}.$$

The trigger (TR) mechanism to initiate the reaction process is the electric arc that polarizes the carbon and hydrogen atoms to form magneuclear clusters. On the atomic distances between the axially coupled atoms, the extremely strong

magnetic fields generated by the arc toroidally deform the atomic orbitals and thereby exposing the nuclei from their electronic clouds. The close proximity of the bare nuclei leads to the nuclear fusion with the generation of excess heat.

The hadronic reactor was pressurized with pure deuterium gas by first evacuating with a mechanical vacuum pump the chamber and then backfilling with the gas from a supply bottle. Gas samples were taken before and after each initiated reaction, and sent to an independent laboratory for spectra vapor analysis.

Each experimental run was started close to ambient temperature of nominally 25°C, with the electric arc powered for 2 minutes. The wattmeter measured an average power consumption of 1550 Wh, which equates to an energy input of 5.4 MJ. A total of 3 runs were performed at varying starting pressures of 100, 75 and 50 psi.

For the 100 psi tests, gas samples before (A) and after (B) was taken. The reactor chamber was then purged and refilled with pure deuterium, and a gas sample (C) was taken at a starting pressure of 75 psi. After the reaction process at 75 psi, a gas sample (D) was extracted. The reactor was then allowed to cool back to ambient and the pressure reduced to 50 psi for another reaction, and a final gas sample (E) taken.

7.3.M.C Gas spectra analysis

Deuterium is non-combustible, and there were also negligible amount of oxygen contained in the hadronic reactor for any other combustion processes to have occurred. Hence if there were no hadronic chemistry or fusion processes taking place then we would expect to observe similar vapor spectra for the samples taken before and after initiation by the electric arc. The analyzed mass spectra for the 5 gas samples, the reported values in parts-per-million (ppm) by volume were accurately reported in the table below.

The spectral analysis indicates a reduction in the amount of deuterium following each reaction. At 100 psi (A → B) the decrease was approximately 2.5%, and at 75 psi (C → D) it was 3%. The decrease in the amount of nitrogen in the 100 psi data can be misleading, since the evolved nitrogen can be trapped in clustered magneules as indicated by the existence of higher mass entities in the spectral data following all the reactions. These previously unknown higher mass magneules are further evidence of the hadronic chemistry taking place.

7.3.M.D Elemental microanalysis

Samples of deposits on the surface of the graphite electrodes were removed for material characterization in a Scanning Electron Microscope (SEM) using an Energy Dispersive Spectroscopy (EDS) X-ray detector. The detector is a liquid-nitrogen cooled lithium-drifted silicon crystal biased to operate as a semiconductor junction. X-rays liberate electron-hole pairs in the junction, and the

amu	A	B	C	D	E
2 (H ₂)	288,163	185,549	141,308	158,837	201,992
3	49,815	438,891	64,969	461,037	1,031,783
4 (D ₂)	12,648,080	12,342,540	11,357,960	11,013,180	10,311,080
5	332	933	223	840	1,771
6	13,260	12,020	10,532	9,793	9,018
7	-	-	190	186	161
8	-	-	-	-	-
11	-	-	-	-	40
12	4,850	9,025	620	19,668	32,411
13	449	400	60	454	1,089
14	57,902	11,191	104,309	118,343	125,036
15	1,875	1,578	653	1,644	3,369
16	24,627	16,952	34,481	26,993	54,958
17	2,269	12,165	4,479	23,534	155,606
18 (Ar, H ₂ O)	10,248	104,140	18,576	186,414	679,276
19	3,242	8,594	2,823	13,890	174,468
20	8,302	71,458	9,302	114,013	182,857
21	-	729	-	1,216	2,315
22	222	159	-	197	222
23	-	-	-	-	-
24	182	218	-	161	1,025
25	633	240	-	61	323
26	2,838	1,408	245	1,103	4,415
27	873	878	-	-	3,145
28 (N ₂)	536,530	125,200	884,507	1,148,545	1,301,279
29	4,334	2,548	6,463	10,666	14,491
30	3,618	5,306	5,526	10,963	22,688
31	178	1,601	343	2,034	7,569
32 (O ₂)	111,498	13,475	205,287	17,979	42,656
33	139	483	201	622	3,539
34	577	1,449	1,134	2,197	3,429
35	-	225	-	236	933
36	-	1,848	142	2,840	4,621
37	-	79	-	-	207
38	-	119	-	100	161

Figure 7.26. A view of the the data collected by L. Yiung and associates on the five samples of tested gases.

amount of charge collected is proportional to the X-ray energies. The electron beam striking the samples generates electronic excitation, and it is the decay of these electronic shells that emits the characteristic X-ray energies unique to each element.

The EDS detector is a PGT's model LS10133 mounted to an ISI Super IIIA SEM. The samples were epoxied to a holder placed directly in line with the electron beam. The long vacuum insulated endcap housing the Si(Li) crystal is inserted into the SEM chamber in close proximity to the sample. Fluorescence X-rays scattering off the target sample and entering the endcap through a thin-walled polymer window are identified by the EDS detector system.

The elemental microanalysis spectra taken on the surface deposits of the graphite electrodes show a prominent X-ray peak at 277 eV (carbon K_α). There is a small

39	308	433	104	161	328
40	5,857	563	10,687	11,468	11,465
41	209	328	80	183	436
42	197	317	102	246	654
43	113	295	-	188	732
44 (CO ₂)	14,262	13,828	1,848	14,241	13,508
45	199	265	-	212	282
46	98	159	-	121	308
47	-	-	-	-	-
48	-	-	-	-	99
50	111	208	-	101	317
51	107	218	-	61	2,740
52	109	295	-	207	459
53	-	107	-	-	102
54	-	176	-	101	223
55	-	185	-	-	141
56	-	208	-	128	306
57	-	-	-	-	40
58	-	-	-	-	140
60	-	-	-	81	121
67	-	-	-	-	-
69	-	-	-	-	391
71	-	-	-	-	-
77	-	137	-	65	-
78	306	464	100	238	243
79	-	115	-	-	-
81	-	60	-	-	-
82	-	132	-	81	130
83	-	60	-	40	131
84	-	472	-	396	734
91	-	162	-	-	-
101	-	-	-	-	711

Figure 7.26 (continued).

adjacent peak at 392 eV, which is the nitrogen K_{α} X-ray that is noticeable above the general background level. Since the SEM chamber is under vacuum, then the detected nitrogen must exist in some non-gaseous form, possibly within clustered magneucles.

7.3.M.E Thermal analysis

Platinum resistive temperature sensors were securely fastened to the surfaces of the steel chamber's central tube and one of the endplates. Temperature readings were noted down each minute after the electric arc was powered up to produce a thermal profile of the hadronic reactor. A thermal Finite Element Analysis (FEA) was simulated for the reactor to estimate the expected temperature rise if the only source of heat came from the electric arc. Comparison curves of the measured thermal profiles against the FEA computed values at 5 MJ, 5.5 MJ and 6 MJ energy inputs are shown below.

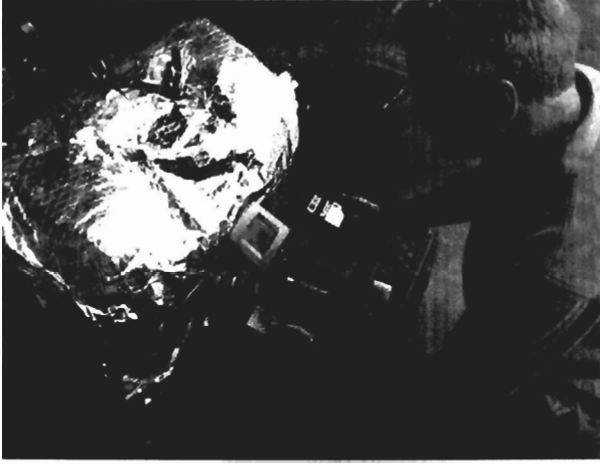

Figure 7.27. A view of T. Kuliczkowski from PGTI during one of the several measurements of lack of any harmful radiation with three different detectors.

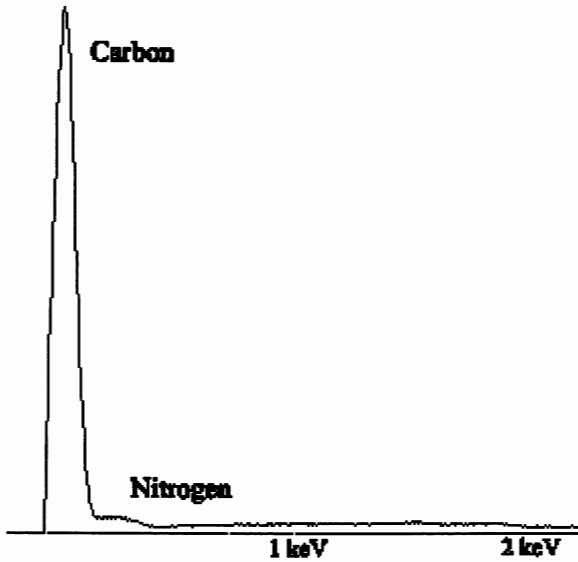

Figure 7.28. Elemental spectra of deposits on graphite electrode.

The data indicates the generated excess heat ΔE_{heat} of approximately 0.5 MJ above the total injected energy input of 5.4 MJ from the electric arc. From Eq. (7.45) we note that each reaction releases around 10 MeV of fusion energy, hence if we assume all the excess heat is through the ICNF process, then this is equivalent to the generation of roughly 10^{18} or a micro-mole of fusion products.

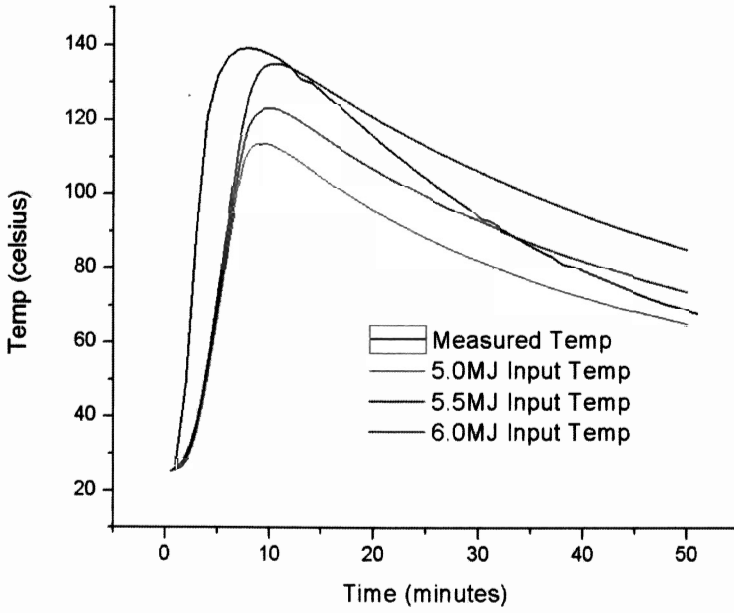

Figure 7.29. Thermal profiles of tube.

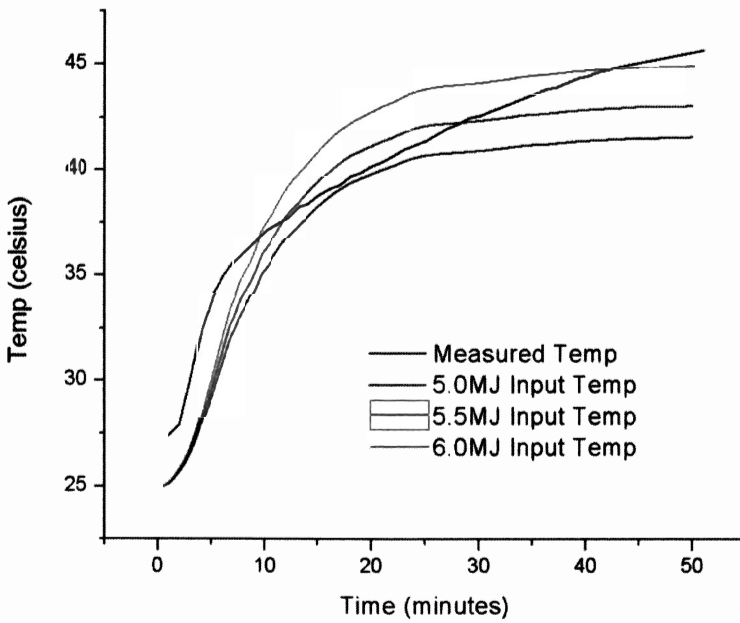

Figure 7.30. Thermal profiles of endplate.

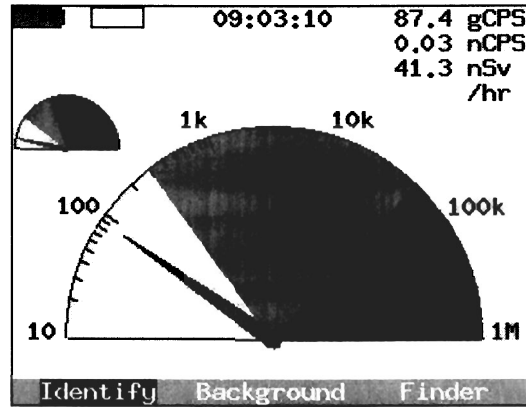

Figure 7.31. SAM940 Gamma and neutron detection.

7.3.M.F Radiation Analysis

The SAM940 sodium iodide scintillator detector is self-calibrating at the potassium (^{40}K) energy of 1.461 MeV. The helium (^3He) proportional counter was factory calibrated against a californium (^{252}Cf) neutron source. For safety and security reasons the source is embedded in wax and locked inside a steel vault. Opening the vault door and placing the SAM940 instrument approximately a meter from the source, we were able to detect average neutron levels of 0.8 counts per second (cps). With the vault door closed and the instrument removed from the vicinity, the background levels fell to less than 0.03 cps.

Compared to normal background levels there were no emitted gamma-rays or neutrons detected emanating from the hadronic reactor during the fusion process occurring within the chamber.

7.3.M.G Conclusions

In conclusion, the 2010 paper by L. Ying and his collaborators confirms all discoveries presented by Santilli in his 2010 paper, namely:

- 1) Due to the lack of any possible combustion in a metal chamber filled up with pure deuterium gas traversed by a DC arc between carbon electrodes, the excess energy detected by the experimentalists over the energy of the DC arc is necessarily due to nuclear fusions. Inspection of chemical analyses before and after the tests as well as examination of the case, reveal that the sole possible fusion is that first achieved by Santilli from deuterium and carbon.

- 2) Systematic measurements conducted with various detectors have confirmed that no harmful radiation of any type was detected in any of the tests outside the hadronic reactor, thus confirming that said nitrogen synthesis occurs without the emission of neutron or other harmful radiation. Additional inspections of



Figure 7.32. A view of the participants in the verification of the nitrogen synthesis from carbon and deuterium, showing from the left: G. West (IBR), R. M. Santilli (IBR), R. Brenna (PGTI), L. Ying (PGTI), M. Rodriguez (IBR), T. Kuliczowski (PGTI), and C. Lynch (IBR). The picture also shows the used equipment consisting from the left: the hadronic reactor of Figure 7.18 with proper thermal insulation; the Miller Dimension 1000 AC-DC converter with accurate wattmeters in its top; the vacuum pump; various deuterium pressure bottles; and a number of radiation detectors, temperature sensors and other instruments.

the interior of the hadronic reactor following the tests confirmed Santilli's finding that said nitrogen synthesis is achieved without any release of harmful waste. In any case, a study of the case establishes the lack of energy necessary for the fission of the carbon and/or deuterium nuclei as a pre-requisite for the emission of harmful radiation, as a result of which either the deuterium and carbon nuclei fuse into the nitrogen nucleus, or they do not, without any possibility of releasing harmful radiation or waste.

3) Examination of chemical analyses of the deuterium gas before and after being traversed by a DC arc establishes the creation in the latter case of new heavy chemical species detectable all the way to 400 amu, a number of which detected in macroscopic percentages, which new species cannot possibly exist in a pure deuterium gas. This evidence disproves in a final way the widespread opinion that the new species are "fragments" of heavier molecules, since the latter did not exist in the original deuterium gas. The same evidence dismisses the possibility that the new species have a valence bond since DC arcs notoriously break down valence bonds and cannot possibly create any. Consequently, the independent evidence gathered by the three nuclear physicists from Princeton, NJ, provides

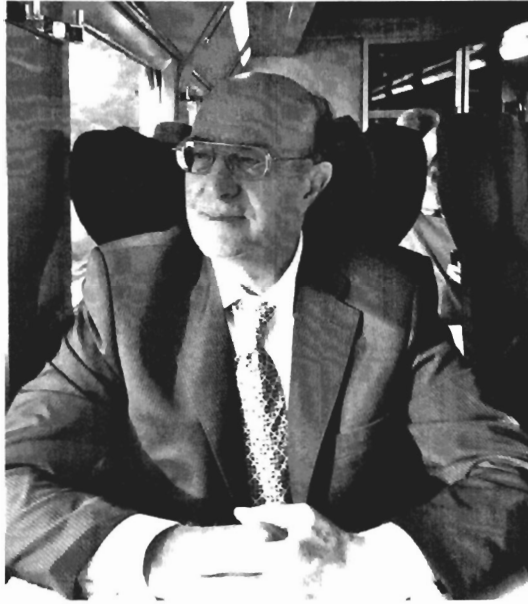

Figure 7.33. A picture of Prof. Santilli on September 25, 2010, at age 76, taken by his son Ermanno on a “Train de Grand Vitesse” in Europe while heading to deliver a lecture at the WETSUS Institute in The Netherlands (a world leader for studies on water) on the need to verify experimentally the inapplicability of special relativity within physical media such as water (see Chapter 5), due to very large scientific, social and environmental implications, including the capability to predict, basically new, much needed new clean energies studied in this chapter.

experimental confirmation of the existence of the new chemical species of Santilli magneucles.

7.4 New Hadronic Energies of Particle Type

7.4.A Introduction

In this section we introduce a third class of new hadronic energies, those of particle type in the sense that they originate in the structure of *individual* composite particles, rather than in their collection. The new energy was called hadronic because essentially dependent for its prediction and quantitative treatment of hadronic mathematics, mechanics and chemistry.

This third class of new energies was introduced for the first time in the paper [87] that initiated the content of this chapter, hereinafter referred as the 1994 paper, which remains to this day the most comprehensive and authoritative treatment in the field. Santilli’s last study of the new hadronic energy of particle type can be found in the 1999 monograph [17]. In this section, we shall follow almost *ad litteram* the excellent review [197] by Jerdsay Kadeisvili of 2008.

7.4.B The stimulated decay of the neutron

Santilli has repeatedly stressed in his writings that *the neutron is an unlimited possible source of energy because it can decay via the release of a highly energetic electron easily trapped with a metal shield*, plus the innocuous neutrino, if it exists.

Following his research on the *synthesis of the neutron* outlined in the preceding chapter, Santilli conducted comprehensive studies on the *stimulated decay of the neutron* because of the possibility of producing a new form of clean energy he called hadronic energy from the methods of its conception and treatment.

Whether successful or not, these studies are the very first and only studies known to the author on possible practical applications of hadron physics. In fact, the theory of electromagnetic interactions produced historical, well known applications while, by comparison, prior to Santilli's 1994 paper the theory of strong interactions had produced no practical application whatsoever, not even remote or conceivable.

As it is well known, the neutron is *naturally* unstable with a meanlife when isolated of about 15 m and with a variable meanlife ranging from a few seconds, when member of certain nuclei, all the way to full stability, when member of other nuclei. Hence, it is quite plausible to expect that the neutron admits one or more *triggers* (TR) under which we have the stimulated decay



where β^- is conventionally interpreted, e.g., as having spin zero for the conservation law of the angular momentum when the trigger has also spin zero (the case with spin 1 will be indicated when needed). In particular, β^- can be interpreted either as an electron and a neutrino or as an electron and an antietherino with opposing spin 1/2. This difference is irrelevant for the stimulated decay of the neutron and, consequently, it will be ignored hereon.

Stimulated decay (7.46) is strictly prohibited by quantum mechanics at large and by the standard model in particular. Under the belief that quarks are the actual physical constituents of hadrons, there is no possibility to stimulate the decay of the neutron, and this illustrates the social, let alone scientific implications of the belief without serious scrutiny that quarks are physical particles in our spacetime.

However, possibility (7.46) is clearly predicted and quantitatively treated by the covering hadronic mechanics. In fact, hadronic mechanics predicts a variety of possible realizations of the trigger, including triggers acting in the interior of individual neutrons or of nuclei, nuclei, including the possible disruption of the *nonpotential* component of the nuclear force.

It should be indicated that, despite vast and widespread skepticism in academia still persisting at this writing (Fall 2010), the stimulated decay of the neutron has received significant research funds and support from the industry due to the well

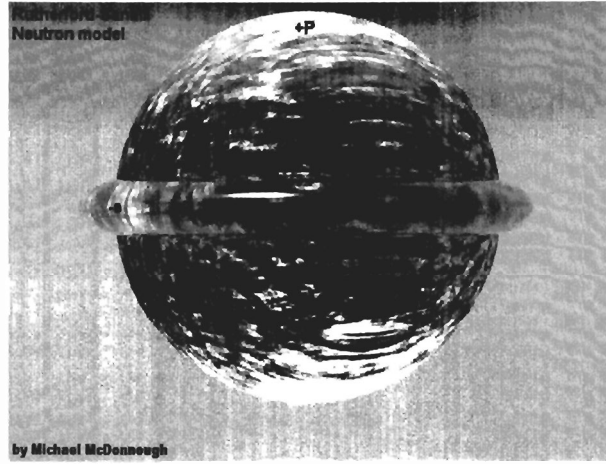

Figure 7.34. An illustration of the support by the industry of research on new clean energies requiring suitable coverings of 20th century doctrines, depicting the conception by Michael McDonnough, President of BetaVoltaic, Inc., of the “Rutherford-Santilli neutron” that is at the foundation of its possible stimulated decay and related new clean energies.

known need for new clean energies as the only way for containing increasingly alarming climactic events,

7.4.C Neutron stimulated decay via photons with resonating frequency

In Chapter 6, we have reviewed Santilli’s synthesis of the neutron from a proton and an electron in mutated isotopic forms. In particular, we have shown that the *isoelectron in the neutron structure is essentially free under MeV energy ranges*, because the binding force is not derivable from a potential, thus carrying no energy. We do have an attractive Coulomb bond derivable from a potential, thus having a negative binding energy, but its (absolute) value is small in MeV unit, thus belonging to refinements not considered here.

Additionally, we have shown that, in the transition from motion in empty space to motion within the hyperdense medium inside the proton, the electron experiences an alteration of its rest energy, called *isorenormalization*, of purely geometrical character due to the mutation of the Minkowskian spacetime caused by hyperdense media, geometric deviations also visible in the variation of the speed of light within physical media and numerous other events.

Therefore, in his 1994 paper Santilli proposed, apparently for the first time that *the neutron can be stimulated to decay via the use of a photon γ_r with a resonating energy (frequency) “r” that is an integer multiple or submultiple of the isorenormalized energy of the isoelectron*,

$$\gamma_r + n \rightarrow p^+ + \beta^-, \quad (7.47a)$$

$$\gamma_r = n \times 1.294 \text{ MeV, or } n \times 3.129 \times 10^{20} \text{ Hz,} \quad (7.47b)$$

$$n = 1, 2, 3, 4, \dots; \text{ or } n = 1/2, 1/3, 1/4, \dots, \quad (7.47c)$$

where the β carries 0.782 MeV of usable energy that is the main target for practical uses.

Jointly, Santilli suggests to consider the natural characteristic frequency of the electron in vacuum as a potential resonating photon, namely

$$\gamma_{r'} = n \times 0.511 \text{ MeV, or } n \times 1.236 \times 10^{20} \text{ Hz,} \quad (7.48a)$$

$$n = 1, 2, 3, \dots; n = 1/2, 1/3, 1/4, \dots \quad (7.48b)$$

Reactions (7.47) or (7.48) are not referred to an isolated neutron in vacuum, but to a neutron when member of a nuclear structure. Hence, in conventional nuclear symbols A, Z, J , amu, the reaction under consideration is written

$$\gamma_r(0, 0, 1) + N(A, Z, J) \rightarrow N(A, Z + 1, J + 1) + \beta^-(0, -1, 0), \quad (7.49)$$

under the verification of all nuclear laws and superselection rules, including the conservation of the energy, charge, angular momentum, parity, etc. Additionally, *the resonating frequency has to be adjusted for nuclear binding forces solely of proved potential origin.*

The mechanism for stimulated decay (7.49) is elementary. The resonating photon hitting a nucleus is expected to excite the isoelectron inside a neutron irrespective of whether the photon penetrates or not inside the neutron. Once excited, there is no possibility for the isoelectron other than that of leaving the neutron structure, thus causing its stimulated decay.

This is due to the fact that hadronic mechanics predicts one and only one energy level for the proton and the electron in conditions of total mutual immersion, the neutron. The range of hadronic mechanics is essentially given by the radius of the neutron (1 fm). Once excited, the isoelectron has no other possibility than that of exiting the proton and reassuming its conventional quantum features when moving in vacuum.

Numerous additional triggers are predicted by hadronic mechanics. Another one Santilli Santilli has been authorized to disclose by his investors is the use of photons with a wavelength equal to the neutron size. In this case, we have the excitation of the neutron as a whole, rather than the isoelectron in its interior, but the predicted result is always the stimulated decay.

As also shown in Chapter 6, see, once the neutron is established as being a bound state of a proton and a (mutated) electron, *nuclei result as being new bound states of protons and electrons, the old interpretation as bound states of protons and neutron being only a first approximation.* Under these new vistas, stimulated decay (7.49) is quite plausible because applicable, for instance, to the isoelectron during exchanges between protons.

Since in practical applications nuclei will not be hit by individual resonating photons, by their coherent beam, Santilli also proposed the study of multiple stimulated decays of peripheral neutrons in a nucleus

$$n\gamma_r(0, 0, 1) + N(A, Z, J) \rightarrow N(A, Z + n, J + m) + n\beta^-(0, -n, 0), \quad (7.50)$$

where $n = 1, 2, 3, \dots$ and the value of m depends on possible polarizations.

Specific examples were proposed in the 1994 paper, among which we recall the use of the isotopes Li(6, 3, -1), Zn(70, 30, 0), S(32, 16, 0) and others (see, for details, the 1999 monograph).

7.4.D Hadronic energy of particle type

Nowadays, there are various forms of hadronic energies under study by the industry. The form that has been disclosed at this writing is based on double beta decays of the type

$$\gamma_r(0, 0, 1) + N(A, Z, J) \rightarrow N(A, Z + 1, J + 1) + \beta^-(0, -1, 0), \quad (7.51a)$$

$$N(A, Z + 1, J + 1) \rightarrow N(A, Z + 2, J + 1) + \beta^-(0, -1, 0), \quad (7.51b)$$

where the first reaction is stimulated and the second is spontaneous.

The original isotope is selected in such a way to meet the following conditions:

1) Admits the stimulated decay of at least one of its peripheral neutrons via one photon with a resonating frequency verifying all conservation laws of the energy, angular momentum, etc.;

2) The new nucleus admits a spontaneous beta decay so that with one resonating photon we have the production of two electrons whose kinetic energy is trapped with a metal shield to produce heat;

3) The original isotope is metallic so that, following the emission of two electrons, it acquires an electric charge suitable for the production of a DC current between metallic the isotope and the metallic shield;

4) The energy balance is positive; and, last but not least

5) The initial and final isotopes are light, natural and stable elements so as to have a new energy that is *clean* in the sense of producing no harmful radiations (since the electrons can be easily trapped with a thin metal shield), and leave no radioactive waste.

When the original isotope meets the above requirements, it is called *hadronic fuel*, and the equipment used for its production is called *hadronic reactor*. It should be stressed that the word "hadronic" here is not intended to strong interactions, but to the use of hadronic mechanics.

7.4.E Hadronic energies via double beta decays

As a result of comprehensive studies, Santilli has indicated that most nuclei do not admit stimulated double decays. However, there exists indeed a class of

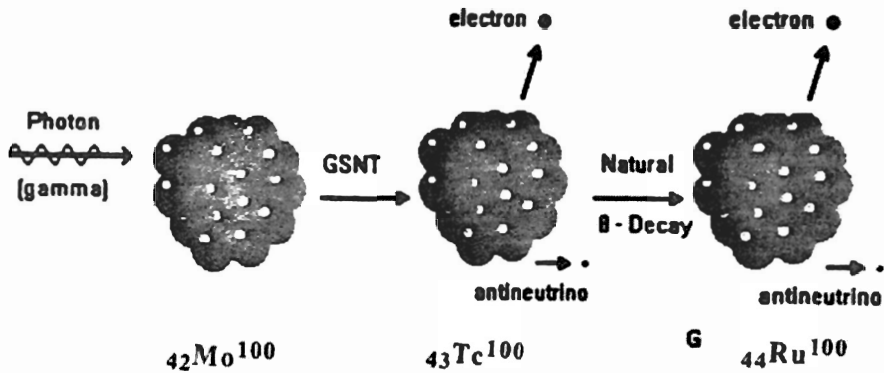

Figure 7.35. A schematic view of the example of hadronic fuel proposed by Santilli in his 1994 paper, the isotope of molybdenum Mo(100, 42, 0). Note that all other Molybdenum isotopes were proved not to admit a stimulated beta decay. Note also that quantum mechanics does predict the double beta decay, but with very small amplitude, thus being of no practical value. Stimulated double decay in appreciable percentage are solely predicted by hadronic mechanics and specifically when using photons with a specific resonating frequency never studied via quantum mechanics.

nuclei admitting indeed the double beta decay, as it is the case for Mo(100, 42, 0). However, as studied, for instance, in the experimental paper [166], the rate of double decay is very small, thus having no practical value.

Santilli has shown that the above studies are based on the *conventional* assumption that neutrons are the final constituents of nuclei (jointly with protons). When neutrons are assumed as a bound state of a proton and an isoelectron, hadronic mechanics does indeed predicts an industrially meaningful rate of double beta decay of the Mo(100, 42, 0).

Additionally, Santilli points out that the peak in the rate of double beta decay occurs, specifically, at the resonating frequency that has never been tested under quantum mechanics. In different words, the calculations the double beta decays made via quantum and hadronic mechanics coincide everywhere except for a peak at the resonating amplitude solely admitted by hadronic mechanics that deserves serious study due to the environmental, let alone scientific implications.

Under the above clarifications, Santilli studied double beta decay as described by hadronic mechanics

$$\gamma_r(0, 0, 1) + \text{Mo}(100, 42, 0) \rightarrow \text{Tc}(100, 43, 1) + \beta^-(0, -1, 0), \quad (7.52a)$$

$$\text{Tc}(100, 43, 1) \rightarrow \text{Ru}(100, 44, 0) + \beta^-(0, -1, 1), \quad (7.52b)$$

where, by using the data from the Table of nuclides <http://atom.kaeri.re.kr>, we have:

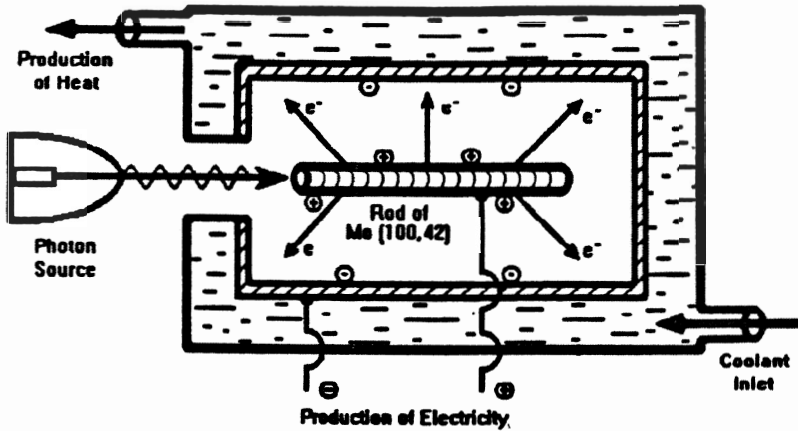

Figure 7.36. A schematic view of the hadronic reactor proposed in the 1994 paper consisting of: a coherent beam of resonating photons hits a bar of Mo(100, 42) with the stimulated transmutation into Tc(100, 43) with the emission of a first highly energetic electron, followed by the spontaneous decay of Tc(100, 43) into Ru(100, 44) with the emission of a second highly energetic electron. The electrons are captured by a metal shield that absorbs also the energy corresponding to the decrease in mass from Mo(100, 42) to Ru(100, 44). Additionally, the difference in potential between Mo(100, 42, 0) and the shield produces a DC current.

- Mo(100, 42, 0) is naturally stable with mass 99.9074771 amu;
- Tc(100, 43) has mass 99.9076576 amu and is naturally unstable with spontaneous decay into Ru(100, 44, 0) and half life of 15.8 s;
- Ru(100, 44) is naturally stable with mass 99.9042197 amu.

As one can see, the mass of Mo(100, 42, 0) is *smaller* than that of Tc(100, 43, 1). Yet, the conservation of the energy can be verified with a resonating frequency of 0.16803 MeV (obtained for $n = 1/7$).

But the mass of the original isotope is *bigger* than that of the final isotope for a value much bigger than that of the resonating photon. with usable hadronic energy (HE) power nuclear reaction

$$\begin{aligned} \text{HE} &= M(100, 42) - M(100, 44) - E(\gamma) - 2 \times E(e) = \\ &= 3.034 - 0.184 - 1.022 \text{ MeV} = 1.828 \text{ MeV}, \quad (7.53) \end{aligned}$$

where Santilli subtracts the conventional rest energy of the two electrons because not usable as a source of energy in this case.

The predicted hadronic energy in this case is *two-fold*, because we first have the production of *heat* acquired by the shield capturing the electrons and, jointly, we have the production of a DC *electric current* between the metal isotope Mo(100, 42, 0) acquiring a positive charge due to the loss of two electrons per

reaction, and the metal shield acquiring two negative charges, by keeping into account that each resonating photon produces two electrons.

To appraise the usable energy, let us recall again, for convenience, the following units and their conversions

$$\begin{aligned} 1 \text{ amu} &= 931.494 \text{ MeV}; \\ 1 \text{ MeV} &= 1.602 \times 10^{-13} \text{ J} = 4.45 \times 10^{-17} \text{ Wh} = 1.511 \times 10^{-16} \text{ BTU}; \\ 1 \text{ Wh} &= 3.397 \text{ BTU}; \quad 1 \text{ C} = 6.241 \times 10^{18} e; \quad 1 \text{ A} = 1 \text{ C}/1 \text{ s}, \end{aligned} \quad (7.54)$$

where “ e ” is the elementary charge of the electron.

Under the assumptions of using a coherent beam with resonating photons (today produced from synchrotrons of a few meters in diameter) hitting a sufficient mass of Mo(100, 42, 0) suitable to produce 10^{20} stimulated nuclear transmutations (102) per our, we have the following:

Hadronic production of heat: $2 \times 10^{20} \text{ MeV}/\text{h} = 3 \times 10^4 \text{ BTU}/\text{h}$,

Hadronic production of electricity: $2 \times 10^{20} e/\text{h} = 200 \text{ C}/\text{h} = 55 \text{ mA}$.

Needless to say, the above is merely an illustrative example, with numerous possibilities for improvements, such as the production of much bigger heat via the selection of a heavier hadronic fuel, the increase of the efficiency by adding triggers, etc.

7.4.F *Tsagas experiment on the Stimulated Neutron Decay*

The experimental verification of stimulated nuclear transmutation (7.53) was initiated by N. Tsagas and his group at the Nuclear Engineering Department of the University of Thrace, Xanthi, Greece, with preliminary, yet positive results presented in the paper [174].

The test was conducted quite simply by using a disk of the radioactive isotope Eu(152, 63, 3) as the source of resonating photons placed next to a disk of *natural* Molybdenum as target while measuring: the background: without any source; the emission with the Europa source alone; and the emission with the joint disks of Europa and natural Molybdenum.

Electrons originating from the Compton scattering of photons with peripheral atomic electrons can at most have 1 MeV energy, as well known. Therefore, the detection of electrons with energy over 2 MeV or more establishes their nuclear origin.

Since the Europa source does not emit electrons, and the Molybdenum is stable, the only possible origin of emitted electrons is due to the stimulated decay of neutrons inside the Molybdenum disk. As recalled earlier, the first reaction (7.51a) emits electrons with minimal energy of 2.8 MeV, while the second reaction emits electrons with energy ranging from 2.22 MeV to 3.38 MeV.

It should be indicated that Tsagas’s test has the following limitations:

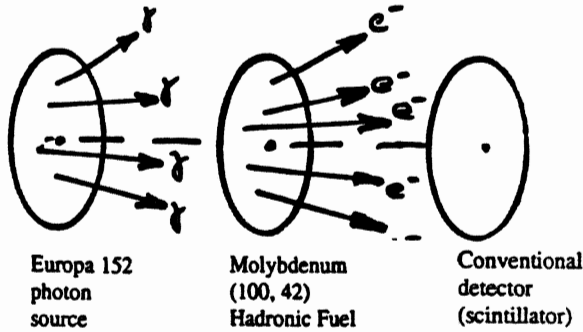

Figure 7.37. The set up of Tsagas experiment [174] on Santilli's stimulated decay of the neutron [87].

A) The tests used ordinary Molybdenum, that contains the isotope Mo(100, 42, 0) only in 0.6%, while all the remaining isotopes of the Molybdenum cannot admit the stimulated decay here considered for various reasons.

B) The primary frequency emitted by the Europa isotope, 1.874 MeV, is not the resonating frequency that should instead be 1.294 MeV less the correction due to the nuclear binding energy, although Eu(152, 63, 3) does emit a number of additional photons, one of which has the energy of 0.148 MeV close to the subharmonic of the resonating energy.

C) The tests solely used detectors of the energy of the emitted particle, without additional detectors for the identification of their nature.

Under these conditions, the possibilities of achieving reaction (7.51) are rather limited. Yet Tsagas did indeed report the detection of emissions in the sole Eu-Mo coupling in excess of 1 MeV, as shown in the figure below.

In summary, far from being final, Tsagas tests remain the first experiment on Santilli's hadronic energy and, despite their limitations, they were indeed positive. It is regrettable, and in actuality hard to believe, that the nuclear physics community has ignored the finalization of Tsagas experiment for its confirmation or dismissal, despite its very moderate cost, while preferring much more expensive experiments that, however, are fully aligned with 20th century sciences.

7.4.G Recycling of radioactive nuclear waste via their stimulated decay

One of the most important implications of Santilli's studies on the structure, synthesis and stimulated decay of the neutron is their application to the recycling of highly radioactive nuclear waste via its stimulated decay as presented in the paper [97]. A scholar presentation is available in the book [190]. A review of the

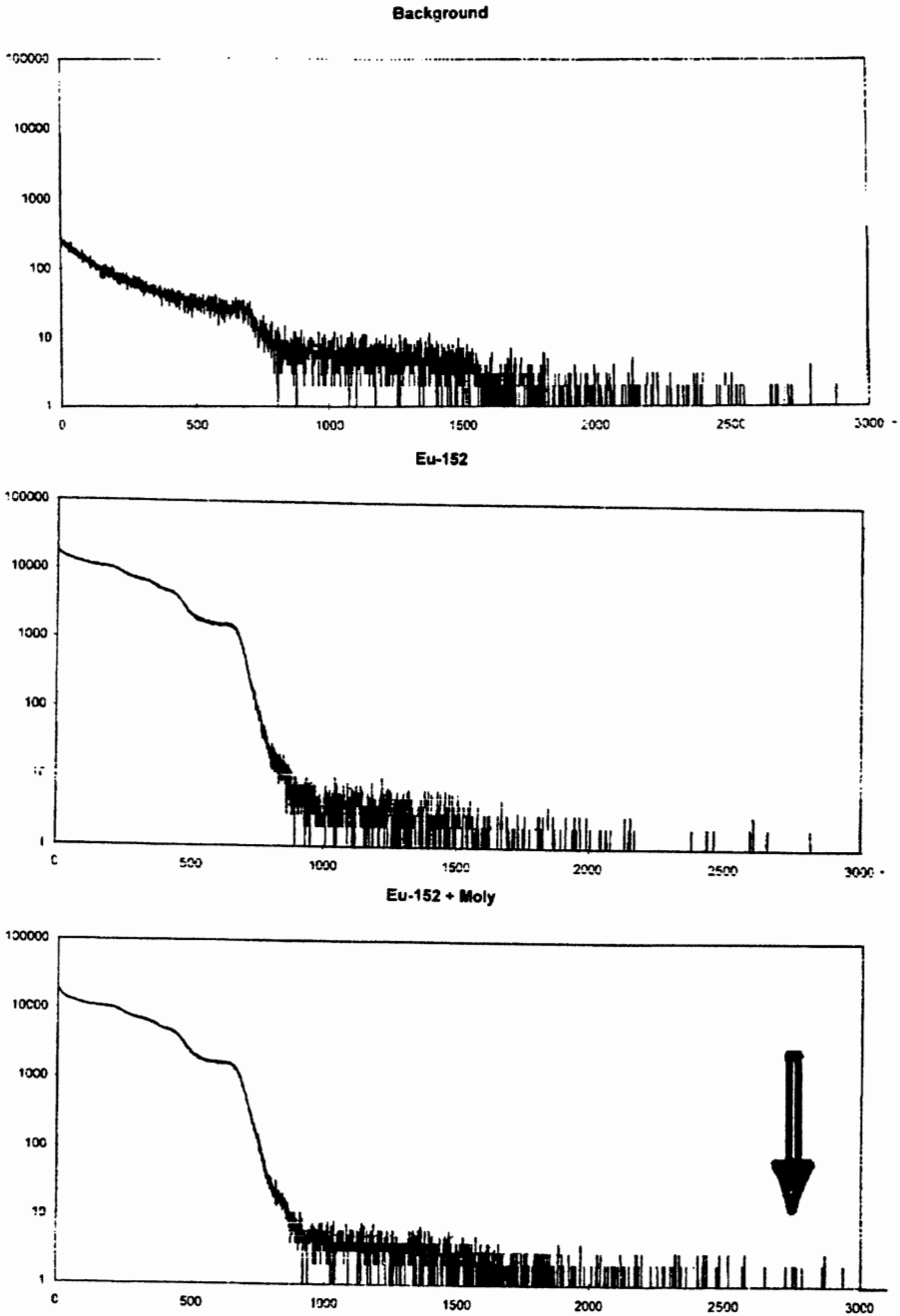

Figure 7.38. A view of the detection by Tsagas for the background, the Europa isotope alone, and the Europa-Molybdenum paid (below) showing the detection of emission over 1 MeV that can solely be of nuclear origin, thus confirming, although in a preliminary way, Santilli prediction [87].

studies including and indication of the obstructions against their realization can be found in the website [205].

Needless to say, the expected solution is expected from a combination of methods, including Santilli's stimulated decay, but also including other approaches some of which have been patented. Most importantly, the equipment expected from these efforts is sufficiently small to be usable by the nuclear power plants themselves, thus avoiding the very dangerous and extremely expensive transportation of the waste to depositories for our descendants to recycle.

The implications are here far reaching because, on one side conventional nuclear power plants can become environmentally more acceptable while, on the other side, we can have the birth of a new multi-billion dollar industry.

Regrettably, the obstructions against the recycling of nuclear waste via its stimulated decay are beyond the imagination by most scientists. On one side, such as recycling would signal the termination of the dominance of quantum mechanics in nuclear physics. On the other side it would imply the termination of the ongoing one trillion dollars expenditures for the storage of the radioactive nuclear waste in the Yucca mountains. As a result, Santilli was forced to halt all his research in the field, and pledge never to resume it (as stated in his 2008 monographs) because of apparent life treats reported in the above quoted website.

The unreassuring information known to the authors is that, to our best knowledge at this writing (Fall 2010) no additional theoretical or experimental study in the recycling of radioactive waste via its stimulated decay has occurred since 1997.

7.5 Epilogue

It is hoped this monograph has illustrated the main guiding principles adopted by Santilli during his 50 years old journey of scientific discoveries, namely:

PRINCIPLE I: There cannot be truly new clean energies and fuels without truly new physical and chemical theories;

PRINCIPLE II: There cannot be truly new physical and chemical theories without truly new mathematics; and

PRINCIPLE III: There cannot be truly new mathematics without new numbers.



Bibliography

All works in pdf format listed in this bibliography can be freely downloaded from the website <http://www.santilli-foundation.org/references>.

- [1] R. M. Santilli, *Foundations of Theoretical Mechanics, I: The Inverse Problem in Newtonian Mechanics*, Springer-Verlag (1978), <http://www.santilli-foundation.org/docs/Santilli-209.pdf>.
- [2] R. M. Santilli, *Foundations of Theoretical Mechanics, II: Birkhoffian Generalization of hamiltonian Mechanics*, Springer-Verlag (1983), <http://www.santilli-foundation.org/docs/santilli-69.pdf>.
- [3] R. M. Santilli, *Lie-Admissible Approach to the Hadronic Structure, I: Non-applicability of the Galilei and Einstein Relativities?* Hadronic Press (1978), <http://www.santilli-foundation.org/docs/santilli-71.pdf>.
- [4] R. M. Santilli, *Lie-Admissible Approach to the Hadronic Structure, II: Coverings of the Galilei and Einstein Relativities?* Hadronic Press (1982), <http://www.santilli-foundation.org/docs/santilli-72.pdf>.
- [5] R. M. Santilli, *Ethical Probe of Einstein's Followers in the USA: An Insider's View*, Alpha Publishing (1984), <http://www.scientificethics.org/ilgrandegriddoedfig.pdf>.
- [6] R. M. Santilli, *Documentation of the Ethical Probe: Vol. I*, Alpha Publishing (1984), <http://www.scientificethics.org/Volume1.pdf>.
- [7] R. M. Santilli, *Documentation of the Ethical Probe: Vol. II*, Alpha Publishing (1984), <http://www.scientificethics.org/Volume2.pdf>.
- [8] R. M. Santilli, *Documentation of the Ethical Probe: Vol. III*, Alpha Publishing (1985), <http://www.scientificethics.org/Volume3.pdf>.
- [9] R. M. Santilli, *Isotopic Generalizations of Galilei's and Einstein's Relativities, Vol. I: Mathematical Foundations*, Hadronic Press (1991), <http://www.santilli-foundation.org/docs/Santilli-01.pdf>.
- [10] R. M. Santilli, *Isotopies of Galilei and Einstein Relativities, Vol. II: Classical Foundations*, Hadronic Press (1991), <http://www.santilli-foundation.org/docs/Santilli-35.pdf>.
- [11] R. M. Santilli *Elements of Hadronic Mechanics, Vol. I: Mathematical Foundations*, Ukrainian Academy of Sciences (1993), <http://www.santilli-foundation.org/docs/Santilli-63.pdf>.

- [12] R. M. Santilli *Elements of Hadronic Mechanics, Vol. I: Mathematical Foundations*, 2nd edition, Ukrainian Academy of Sciences (1995), <http://www.santilli-foundation.org/docs/Santilli-300.pdf>.
- [13] R. M. Santilli, *Elements of Hadronic Mechanics. Vol. II: Theoretical Foundations*, Ukrainian Academy of Sciences (1994), <http://www.santilli-foundation.org/docs/Santilli-02.pdf>.
- [14] R. M. Santilli, *Elements of Hadronic Mechanics. Vol. II: Theoretical Foundations*, 2nd edition, Ukrainian Academy of Sciences (1995), <http://www.santilli-foundation.org/docs/Santilli-301.pdf>.
- [15] C. R. Illert and R. M. Santilli, *Foundation of Theoretical Conchology*, Hadronic Press (1995), <http://www.santilli-foundation.org/docs/Santilli-109.pdf>.
- [16] R. M. Santilli, *Isotopic, Genotopic and Hyperstructural Methods in Theoretical Biology*, Ukrainian Academy of Sciences (1997), <http://www.santilli-foundation.org/docs/santilli-67.pdf>.
- [17] R. M. Santilli, *The Physics of New Clean Energies and Fuels According to Hadronic Mechanics*, published in a special issue of the Journal of New Energy, Vol. 4, pages 1-314 (1999), <http://www.santilli-foundation.org/docs/Santilli-114.pdf>.
- [18] R. M. Santilli, *Foundations of Hadronic Chemistry, with Applications to New Clean Energies and Fuels*, Kluwer Academic Publishers (2001), <http://www.santilli-foundation.org/docs/Santilli-113.pdf>.
- [19] R. M. Santilli, *Isodual Theory of Antimatter, with Applications to Antigravity, Grand Unification and Cosmology*, Springer (2006), <http://www.santilli-foundation.org/docs/santilli-79.pdf>.
- [20] R. M. Santilli, *Hadronic Mathematics, Mechanics and Chemistry, Volume I: Limitations of Einstein's Special and General Relativities, Quantum Mechanics and Quantum Chemistry*, International Academic Press (2008), <http://www.i-b-r.org/docs/HMMC-1-02-26-08.pdf>.
- [21] R. M. Santilli, *Hadronic Mathematics, Mechanics and Chemistry, Volume II: Isodual Theory of Antimatter, Antigravity and Spacetime Machines*, International Academic Press (2008), <http://www.i-b-r.org/docs/HMMC-II-01-19-08.pdf>.
- [22] R. M. Santilli, *Hadronic Mathematics, Mechanics and Chemistry, Volume III: Iso-, Geno-, Hyper-Formulations for Matter and Their Isoduals for Antimatter*, International Academic Press (2008), <http://www.i-b-r.org/docs/HMMC-III-02-26-08.pdf>.

- [23] R. M. Santilli, *Hadronic Mathematics, Mechanics and Chemistry, Volume IV: International Academic Press* (2008), <http://www.i-b-r.org/docs/HMMC-12-15-08.pdf>.
- [24] R. M. Santilli, *Hadronic Mathematics, Mechanics and Chemistry, Volume V: Experimental Verifications, Theoretical Advances and Industrial Applications in Chemistry, International Academic Press* (2008), <http://www.i-b-r.org/docs/HMMC-V-01-26-08.pdf>.
- [25] R. M. Santilli, *The New Fuels with Magnecular Structure, International Academic Press* (2005), <http://www.i-b-r.org/docs/Fuels-Magnecular-StructureF.pdf>; Italian translation "I Nuovi Carburanti con Struttura Magnecolare" by Giovanna Bonfanti and Michele Sacerdoti, published by Editori Riuniti, Roma, Italy, and available at <http://www.i-b-r.org/docs/Carb-Strutt-Magnecolare.doc>.
- [26] *Albert Einstein*, Seminar delivered by R. M. Santilli in 1952 at the High School in Agnone (Isernia), Italy, <http://www.santilli-foundation.org/docs/santilli-75.pdf>.
- [27] R. M. Santilli, *Principi su una Teoria Unificata sulla Fisica Atomica (Principles for a Unified Theory in Atomic Physics)*, Naples (1955), <http://www.santilli-foundation.org/docs/Santilli-76.pdf>.
- [28] R. M. Santilli, *Eliminazione della massa nella fisica atomica (Elimination of mass in atomic physics)*, Phoenix, Vol. 1, 222-227 (1955), <http://www.santilli-foundation.org/docs/santilli-77.pdf>.
- [29] R. M. Santilli, *Perche' lo spazio e' rigido (Why space is rigid)*, Il Pungolo verde, Campobasso, Italy, (1956), <http://www.santilli-foundation.org/docs/Santilli-49.pdf>.
- [30] R. M. Santilli, *Fondamenti per una teoria unificata sulla struttura dell'elettrone (Foundations for a unified theory on the structure of the electron)*, Department of Nuclear Physics, University of Naples (1959), <http://www.santilli-foundation.org/docs/santilli-78.pdf>.
- [31] R. M. Santilli, *Principi per una Teoria Unitaria sulla Struttura dell'Elettrone, del Positrone e dei Campi ad Essi associati* (1963).
- [32] R. M. Santilli, *Imbedding of Lie-algebras in nonassociative structures*, Nuovo Cimento, Vol. 51, 570-576 (1967), <http://www.santilli-foundation.org/docs/Santilli-54.pdf>.
- [33] R. M. Santilli, *An introduction to Lie-admissible algebras*, Supplemento al Nuovo Cimento, Vol. 6, 1225-1249 (1968), <http://www.santilli-foundation.org/docs/Santilli-101.pdf>.

- [34] R. M. Santilli, *Dissipativity and Lie-admissible algebras*, Meccanica, Vol. 4, 3–11 (1969), <http://www.santilli-foundation.org/docs/Santilli-105.pdf>.
- [35] J. Aghassi, P. Roman and R. M. Santilli, *A new dynamical group for the relativistic quantum mechanics of elementary particles*, Phys. Rev. D, Vol. 1, 2753–2765 (1970), <http://www.santilli-foundation.org/docs/Santilli-55.pdf>.
- [36] J. J. Aghassi, P. Roman and R. M. Santilli, *Representation theory of a new relativistic dynamical group*, Nuovo Cimento, Vol. 5, 551–590 (1971), <http://www.santilli-foundation.org/docs/Santilli-103.pdf>.
- [37] R. M. Santilli and C. N. Ktorides, *Generalization of the PCT theorem to all discrete spacetime symmetries in quantum field theory*, Phys. Rev. D, Vol. 10, 3396–3406 (1974), <http://www.santilli-foundation.org/docs/santilli-80.pdf>.
- [38] R. M. Santilli and C. N. Ktorides, *Can the generalized Haag theorem be further generalized?* Phys. Rev. D, Vol. 7, 2447–2456 (1973), <http://www.santilli-foundation.org/docs/Santilli-57.pdf>.
- [39] R. M. Santilli, *Partons and gravitation: some puzzling questions*, (MIT) Annals of Physics, Vol. 83, 108–157 (1974), <http://www.santilli-foundation.org/docs/Santilli-14.pdf>.
- [40] R. M. Santilli, *Necessary and sufficient conditions for the existence of a Lagrangian in field theory, I: Variational approach to selfadjointness for tensorial field equations*, (MIT) Ann. Phys., Vol. 103, 354–408 (1977), <http://www.santilli-foundation.org/docs/Santilli-45.pdf>.
- [41] R. M. Santilli, *Necessary and sufficient conditions for the existence of a Lagrangian in field theory, II: Direct analytic representation of tensorial field equations*, (MIT) Ann. Phys., Vol. 103, 409–468 (1977), <http://www.santilli-foundation.org/docs/Santilli-46.pdf>.
- [42] R. M. Santilli, *Necessary and sufficient conditions for the existence of a Lagrangian in field theory, III: Generalized analytic representations of tensorial field equations*, (MIT) Ann. Phys., Vol. 105, 227–258 (1978), <http://www.santilli-foundation.org/docs/Santilli-47.pdf>.
- [43] R. M. Santilli, *On a possible Lie-admissible covering of Galilei's relativity in Newtonian mechanics for nonconservative and Galilei form-noninvariant systems*, Hadronic J., Vol. 1, 223–423 (1978), <http://www.santilli-foundation.org/docs/Santilli-58.pdf>.

- [44] R. M. Santilli, *Need of subjecting to an experimental verification the validity within a hadron of Einstein's special relativity and Pauli's exclusion principle*, Hadronic J., Vol. 1, 574–901 (1978), <http://www.santilli-foundation.org/docs/santilli-73.pdf>.
- [45] C. N. Ktorides, H. C. Myung and R. M. Santilli, *Elaboration of the recently proposed test of Pauli's principle under strong interactions*, Phys. Rev. D, Vol. 22, 892–907 (1980) <http://www.santilli-foundation.org/docs/Santilli-16.pdf>.
- [46] R. M. Santilli, *A structure model of the elementary charge*, Hadronic J., Vol. 4, 770–784 (1981), <http://www.santilli-foundation.org/docs/Santilli-03.pdf>.
- [47] R. M. Santilli, *Experimental, theoretical and mathematical elements for a possible Lie-admissible generalization of the notion of particle under strong interactions*, the Institute for Basic Research Contributed paper to the 1980 Clausthal Conference on Differential Geometric Methods in Mathematical Physics, Hadronic J., Vol. 4, 1166–1257 (1981).
- [48] R. M. Santilli, *An intriguing legacy of Einstein, Fermi, Jordan, and others: The possible invalidation of quark conjectures*, Found. Phys., Vol. 11, 383–472 (1981), <http://www.santilli-foundation.org/docs/Santilli-36.pdf>.
- [49] *Proceedings of the Third Workshop on Lie-Admissible Formulations*, H. C. Myung and R. M. Santilli, Editors, Part A, Hadronic J., Vol. 4, no. 2, pp. 183–607 (1981).
- [50] *Proceedings of the Third Workshop on Lie-Admissible Formulations*, H. C. Myung and R. M. Santilli, Editors, Part B, Hadronic J., Vol. 4, no. 3, pp. 608–1165 (1981).
- [51] *Proceedings of the Third Workshop on Lie-Admissible Formulations*, H. C. Myung and R. M. Santilli, Editors, Part C, Hadronic J., Vol. 4, no. 4, pp. 1166–1625 (1981).
- [52] H. C. Myung and R. M. Santilli, *Foundations of the hadronic generalization of the atomic mechanics, II: modular-isotopic Hilbert space formulation of the exterior strong problem*, Hadronic Journal, Vol. 5, 1277–1366 (1982), <http://www.santilli-foundation.org/docs/Santilli-201.pdf>.
- [53] R. M. Santilli, *Can strong interactions accelerate particles faster than the speed of light?* Lettere Nuovo Cimento, Vol. 33, 145–153 (1982), <http://www.santilli-foundation.org/docs/Santilli-102.pdf>.

- [54] R. M. Santilli, *A possible Lie-admissible time-asymmetric model of open nuclear reactions*, *Lettere Nuovo Cimento*, Vol. 37, 337–344 (1983), <http://www.santilli-foundation.org/docs/Santilli-53.pdf>.
- [55] E. Papp and R. M. Santilli, *A conceivable lattice structure of the Coulomb law*, *Lettere Nuovo Cimento*, Vol. 37, 505–508 (1983), <http://www.santilli-foundation.org/docs/Santilli-56.pdf>.
- [56] R. M. Santilli, *Lie-isotopic lifting of the special relativity for extended deformable particles*, *Lettere Nuovo Cimento*, Vol. 37, 545–555 (1983), <http://www.santilli-foundation.org/docs/Santilli-50.pdf>.
- [57] R. M. Santilli, *Lie-isotopic lifting of unitary symmetries and of Wigner's theorem for extended deformable particles*, *Lettere Nuovo Cimento*, Vol. 38, 509–521 (1983), <http://www.santilli-foundation.org/docs/Santilli-51.pdf>.
- [58] R. M. Santilli, *Lie-isotopic liftings of Lie symmetries, I: General considerations*, *Hadronic J.*, Vol. 8, 25–35 (1985), <http://www.santilli-foundation.org/docs/santilli-65.pdf>.
- [59] R. M. Santilli, *Lie-isotopic liftings of Lie symmetries, II: Lifting of rotations*, *Hadronic J.*, Vol. 8, 36–51 (1985), <http://www.santilli-foundation.org/docs/santilli-66.pdf>.
- [60] R. M. Santilli, *Hadronic J. Suppl.*, Vol. 4A, issues 1, 2, 3, 4 (1988).
- [61] R. M. Santilli, *Operator Isospecial Relativities for Interior Problems in Particle Physics*, *Hadronic J. Suppl.*, Vol. 4B, no. 3 (1989).
- [62] R. M. Santilli, *Apparent consistency of Rutherford's hypothesis on the neutron as a compressed hydrogen atom*, *Hadronic J.*, Vol. 13, 513–531 (1990), <http://www.santilli-foundation.org/docs/Santilli-21.pdf>.
- [63] A. O. E. Animalu and R. M. Santilli, *XXXXXXXXXX*, in “Hadronic Mechanics and Nonpotential Interactions,” M. Mijatovic, Editor, Nova Science, 19–26 (1990), <http://www.santilli-foundation.org/docs/Animalu-Santilli.pdf>.
- [64] R. M. Santilli, *Lie-isotopic generalization of the Poincaré symmetry: classical formulation*, ICTP preprint #IC/91/45 (1991) published in “Santilli's 1991 Papers at the ICTP”, International Academic Press (1992), <http://www.santilli-foundation.org/docs/Santilli-140.pdf>.
- [65] R. M. Santilli, *Theory of mutation of elementary particles and its application to Rauch's experiment on the spinorial symmetry*, ICTP preprint #IC/91/46 (1991) published in “Santilli's 1991 Papers at the ICTP”, In-

- ternational Academic Press (1992), <http://www.santilli-foundation.org/docs/Santilli-141.pdf>.
- [66] R. M. Santilli, *Apparent consistency of Rutherford's hypothesis on the neutron structure via the hadronic generalization of quantum mechanics - I: Nonrelativistic treatment*, ICTP preprint #IC/91/47 (1991) published in "Santilli's 1991 Papers at the ICTP", International Academic Press (1992), <http://www.santilli-foundation.org/docs/Santilli-150.pdf>.
- [67] R. M. Santilli, *Inequivalence of interior and exterior dynamical problems*, ICTP preprint #IC/91/258 (1991) published in "Santilli's 1991 Papers at the ICTP", International Academic Press (1992), <http://www.santilli-foundation.org/docs/Santilli-142.pdf>.
- [68] R. M. Santilli, *Closed systems with non-Hamiltonian internal forces*, ICTP preprint #IC/91/259 (1991) published in "Santilli's 1991 Papers at the ICTP", International Academic Press (1992), <http://www.santilli-foundation.org/docs/Santilli-143.pdf>.
- [69] R. M. Santilli, *Generalized two-body and three-bodies systems with non-Hamiltonian internal forces*, ICTP preprint #IC/91/260 (1991) published in "Santilli's 1991 Papers at the ICTP", International Academic Press (1992), <http://www.santilli-foundation.org/docs/Santilli-139.pdf>.
- [70] R. M. Santilli, *Rotational-isotopic symmetries*, ICTP preprint #IC/91/261 (1991) published in "Santilli's 1991 Papers at the ICTP", International Academic Press (1992), <http://www.santilli-foundation.org/docs/Santilli-148.pdf>.
- [71] R. M. Santilli, *Galilei-isotopic symmetries*, ICTP preprint #IC/91/263 (1991) published in "Santilli's 1991 Papers at the ICTP", International Academic Press (1992), <http://www.santilli-foundation.org/docs/Santilli-147.pdf>.
- [72] R. M. Santilli, *Galilei-isotopic relativities*, ICTP preprint #IC/91/264 published in "Santilli's 1991 Papers at the ICTP", International Academic Press (1992), <http://www.santilli-foundation.org/docs/Santilli-146.pdf>.
- [73] R. M. Santilli, *The notion of nonrelativistic isoparticle*, ICTP preprint #IC/91/265 published in "Santilli's 1991 Papers at the ICTP", International Academic Press (1992), <http://www.santilli-foundation.org/docs/Santilli-145.pdf>.

- [74] F. Cardone, R. Mignani and R. M. Santilli, *On a possible energy-dependence of the K^0/s lifetime*, J. Phys. G: Part. Phys., Vol. 18, L61–L65 (1992).
- [75] F. Cardone, R. Mignani and R. M. Santilli, *On a possible energy-dependence of the K^0/s lifetime*, J. Phys. G: Part. Phys., Vol. 18, L141–L144 (1992).
- [76] R. M. Santilli, *Nonlocal formulation of the Bose-Einstein correlation within the context of hadronic mechanics*, Hadronic J. Vol. 15, 1–134 (1992).
- [77] A. Jannussis, R. Mignani and R. M. Santilli, *Problematic aspects of Weinberg's nonlinear theory*, Ann. Fond. L. de Broglie, Vol. 18, 371–389 (1993), <http://www.santilli-foundation.org/docs/Santilli-123.pdf>.
- [78] R. M. Santilli, *Nonlinear, nonlocal and noncanonical isotopies of the Poincaré symmetry*, J. Moscow Phys. Soc., Vol. 3, 255–280 (1993), <http://www.santilli-foundation.org/docs/Santilli-40.pdf>.
- [79] R. M. Santilli, *Isonumbers and genonumbers of dimension 1, 2, 4, 8, their isoduals, and pseudoduals, and "hidden numbers" of dimension 3, 5, 6, 7*, Algebras, Groups and Geometries, Vol. 10, 273–322 (1993), <http://www.santilli-foundation.org/docs/Santilli-34.pdf>.
- [80] R. M. Santilli, *Isotopic lifting of $SU(2)$ -symmetry with applications to nuclear physics*, JINR Rapid Comm., Vol. 6, 24–38 (1993), <http://www.santilli-foundation.org/docs/Santilli-19.pdf>.
- [81] R. M. Santilli, Communication of the Joint Institute for Nuclear Research, Dubna, Russia, No. E4-93-252 (1993)
- [82] R. M. Santilli, *Recent theoretical and experimental evidence on the apparent synthesis of neutron from protons and electrons*, Communication of the JINR, Dubna, Russia, number JINR-E4-93-352 (1993).
- [83] R. M. Santilli, *A quantitative isotopic representation of the deuteron magnetic moment*, in "Proceedings of the International Symposium 'Dubna Deuteron-93'", Joint Institute for Nuclear Research, Dubna, Russia (1994), <http://www.santilli-foundation.org/docs/Santilli-134.pdf>.
- [84] R. M. Santilli, *Representation of antiparticles via isodual numbers, spaces and geometries*, Comm. Theor. Phys., Vol. 3, 153–181 (1994), <http://www.santilli-foundation.org/docs/Santilli-12.pdf>.
- [85] R. M. Santilli, *Antigravity*, Hadronic J., Vol. 17, 257–284 (1994), <http://www.santilli-foundation.org/docs/Santilli-113.pdf>.
- [86] R. M. Santilli, *Space-time machine*, Hadronic J., Vol. 17, 285–310 (1994), <http://www.santilli-foundation.org/docs/Santilli-10.pdf>.

- [87] R. M. Santilli, *Hadronic energy*, Hadronic J., Vol. 17, 311–348 (1994), <http://www.santilli-foundation.org/docs/Santilli-23.pdf>.
- [88] R. M. Santilli, *Isotopic quantization of gravity and its universal isopoincaré symmetry*, In the Proceedings of “The Seventh Marcel Grossmann Meeting”, R. T. Jantzen, G. M. Keiser and R. Ruffini, Editors, World Scientific Publishers, 500–505 (1994), <http://www.santilli-foundation.org/docs/Santilli-120.pdf>.
- [89] R. M. Santilli, Contributed paper in *Frontiers of Fundamental Physics*, F. Selleri and M. Barone, Editors, Plenum, New York (1994).
- [90] R. M. Santilli, *Recent theoretical and experimental evidence on the apparent synthesis of neutron from protons and electrons*, Chinese J. Systems Engineering and Electronics, Vol. 6, 177–199 (1995), <http://www.santilli-foundation.org/docs/Santilli-18.pdf>.
- [91] R. M. Santilli, *Quantum isogravity*, Communication in Theor. Phys., Vol. 4, no. 2, 1–14 (1995), <http://www.santilli-foundation.org/docs/Santilli-124.pdf>.
- [92] A. O. E. Animalu and R. M. Santilli, *Nonlocal isotopic representation of the Cooper pair in superconductivity*, Intern. J. Quantum Chemistry, Vol. 29, 175–187 (1995), <http://www.santilli-foundation.org/docs/Santilli-26.pdf>.
- [93] R. M. Santilli, *Nonlocal-integral isotopies of differential calculus, mechanics and geometries*, Rendiconti Circolo Matematico Palermo Suppl., Vol. 42, 7–82 (1996), <http://www.santilli-foundation.org/docs/Santilli-37.pdf>.
- [94] R. M. Santilli, *Isotopic unification of gravitation and relativistic quantum mechanics and its universal isopoincaré symmetry*, in “Gravity, Particles and Spacetime,” P. Pronin and G. Sardanashvily, Editors, World Scientific, 369–383 (1996), <http://www.santilli-foundation.org/docs/Santilli-122.pdf>.
- [95] R. M. Santilli and Th. Vougouklis, *Isotopies, Genotopies and Hyperstructures and their applications*, contributed memoir in “New Frontiers in Hyperstructures,” Hadronic Press, 1–48 (1996), <http://www.santilli-foundation.org/docs/San-Vou.pdf>.
- [96] R. M. Santilli, *Isominkowskian formulation of gravitation and cosmology*, in the proceedings of “Modern Modified Theories of Gravitation and Cosmology,” Israel, 1996, E. I. Guendelman, Editor, Hadronic Press, 113–165 (1998).

- [97] R. M. Santilli, *Possible implications of nonlocal-integral effects for new methods of recycling nuclear waste*, in the proceedings of "Large Scale Collective Motion of Atomic Nuclei", G. Giardina, G. Fazio and M. Lattuada, Editors, World Scientific, 549–556 (1996), <http://www.santilli-foundation.org/docs/Santilli-132.pdf>.
- [98] R. M. Santilli, *Does antimatter emit a new light?* *Hyperfine Interactions*, Vol. 109, 63–81 (1997), <http://www.santilli-foundation.org/docs/Santilli-28.pdf>.
- [99] R. M. Santilli, *Relativistic hadronic mechanics: nonunitary, axiom-preserving completion of relativistic quantum mechanics*, *Found. Phys.*, Vol. 27, 625–729 (1997), <http://www.santilli-foundation.org/docs/Santilli-15.pdf>.
- [100] R. M. Santilli, *Invariant Lie-admissible formulation of quantum deformations*, *Found. Phys.*, Vol. 27, 1159–1177 (1997), <http://www.santilli-foundation.org/docs/Santilli-06.pdf>.
- [101] R. M. Santilli, *Isotopic grand unification with the inclusion of gravity*, *Found. Phys. Letters*, Vol. 10, 307–327 (1997), <http://www.santilli-foundation.org/docs/Santilli-04.pdf>.
- [102] R. M. Santilli, *Apparent confirmation of Don Borghi's experiment toward the synthesis of neutron from protons and electrons*, *Hadronic Journal*, Vol. 30, 709 (1997), <http://www.neutronstructure.org/neutron-synthesis.htm>.
- [103] R. M. Santilli, *The synthesis of the neutron according to hadronic mechanics*, website (1997), <http://www.neutronstructure.org/neutron-synthesis.htm>.
- [104] R. M. Santilli, *Isominkowskian geometry for the gravitational treatment of matter and its isodual for antimatter*, *Intern. J. Modern Phys. D*, Vol. 7, 351–407 (1998), <http://www.santilli-foundation.org/docs/Santilli-35.pdf>.
- [105] Yu. Arestov, R. M. Santilli and V. Solovianov, *Experimental evidence on the iso-Minkowskian character of the hadronic structure*, *Found. Phys. Letters*, Vol. 11, 483–493 (1998).
- [106] R. M. Santilli, *Origin, problematic aspects and invariant formulation of q -, k - and other quantum deformations*, *Modern Phys. Lett. A*, Vol. 13, 327–335 (1998), <http://www.santilli-foundation.org/docs/Santilli-48.pdf>.

- [107] R. M. Santilli, *Isorepresentations of the Lie-isotopic $SU(2)$ algebra with applications to nuclear physics and to local realism*, *Acta Applicandae Mathematicae*, Vol. 50, 177–190 (1998), <http://www.santilli-foundation.org/docs/Santilli-27.pdf>.
- [108] R. M. Santilli, *Theoretical prediction and experimental verifications of the new chemical species of magneucules*, *Hadronic J.*, Vol. 21, 789–894 (1998), <http://www.santilli-foundation.org/docs/Santilli-43.pdf>.
- [109] R. M. Santilli, *Nuclear realization of hadronic mechanics and the exact representation of nuclear magnetic moments*, *Intern. J. Phys.*, Vol. 4, 1–70 (1998), <http://www.santilli-foundation.org/docs/Santilli-07.pdf>.
- [110] R. M. Santilli, *Unification of gravitation and electroweak interactions*, In the proceedings of “The Eighth Marcel Grossmann meeting”, Israel 1997, T. Piran and R. Ruffini, Editors, World Scientific, 473–475 (1999), <http://www.santilli-foundation.org/docs/Santilli-137.pdf>.
- [111] R. M. Santilli, *A classical isodual theory of antimatter and its prediction of antigravity*, *Intern. J. Modern Phys. A*, Vol. 14, 2205–2238 (1999), <http://www.santilli-foundation.org/docs/Santilli-09.pdf>.
- [112] R. M. Santilli, *Origin, problematic aspects and invariant formulation of classical and operator deformations*, *Intern. J. Modern Phys.*, Vol. 14, 3157–3206 (1999), <http://www.santilli-foundation.org/docs/Santilli-104.pdf>.
- [113] R. M. Santilli and D. D. Shillady, *A new iso-chemical model of the hydrogen molecule*, *Intern. J. Hydrogen Energy*, Vol. 24, 943–956 (1999), <http://www.santilli-foundation.org/docs/Santilli-135.pdf>.
- [114] R. M. Santilli and D. D. Shillady, *A new isochemical model of the water molecule*, *Intern. J. Hydrogen Energy*, Vol. 25, 173–183 (2000), <http://www.santilli-foundation.org/docs/Santilli-39.pdf>.
- [115] R. M. Santilli, *Direct universality of the isospecial relativity for photons with arbitrary speeds*, in “Photon: Old problems in Light of New Ideas,” V. V. Dvoeglazov, Editor, Nova Science, 421–442 (2000) <http://www.santilli-foundation.org/docs/Santilli-24.pdf>.
- [116] R. M. Santilli, *New problematic aspects of current string theories and their invariant resolution*, *Found. Phys.*, Vol. 32, 1111–1140 (2002), <http://www.santilli-foundation.org/docs/Santilli-42.pdf>.
- [117] R. M. Santilli, *Iso-, geno-, hyper-mechanics for matter, their isoduals for antimatter, and their novel applications in physics, chemistry and*

- biology*, Journal of Dynamical Systems and Geometric Theories, Vol. 1, no. 2, 121–193 (2003), <http://www.santilli-foundation.org/docs/Santilli-115.pdf>.
- [118] R. M. Santilli, *The novel magneuclear species of hydrogen and oxygen with increased specific weight and energy content*, Intern. J. Hydrogen Energy, Vol. 28, 177–196 (2003), <http://www.santilli-foundation.org/docs/Santilli-38.pdf>.
- [119] R. M. Santilli, *Nine theorems of inconsistency in GRT with resolutions via isogravitation*, Galilean Electrodynamics, Summer 2006, 43–52 (2006), <http://www.i-b-r.org/Incons.GravFinalGED-I.pdf>.
- [120] R. M. Santilli, *Lie-admissible invariant treatment of irreversibility for matter and antimatter at the classical and operator levels*, Nuovo Cimento B, Vol. 121, 443–586 (2006), <http://www.i-b-r.org/Lie-admiss-NCB-I.pdf>.
- [121] R. M. Santilli, *A new gaseous and combustible form of water*, Intern. J. Hydrogen Energy, Vol. 31, 1113–1128 (2006), <http://www.santilli-foundation.org/docs/Santilli-138.pdf>.
- [122] R. M. Santilli, *The structure of the neutron as predicted by hadronic mechanics*, website (2006), <http://www.neutronstructure.org>.
- [123] R. M. Santilli, *The etherino and/or the neutrino hypothesis*, Foundation of Physics, Vol. 37, 670 (2007), <http://www.santilli-foundation.org/docs/EtherinoFoundPhys.pdf>.
- [124] R. M. Santilli, *Absence of universe expansion, dark matter and dark energy in the new isocosmology with a universal isosymmetry*, in the Proceedings of the 2007 ICDS, C. Ozel and V. Cay, Editors, International Academic Press (2008), <http://www.santilli-foundation.org/docs/Isocosmology.pdf>.
- [125] R. M. Santilli, *The novel “Controlled Intermediate Nuclear Fusion” and a report on its industrial realization as predicted by hadronic mechanics*, Hadronic J., Vol. 31, 115–200 (2008), <http://www.i-b-r.org/CNF-printed.pdf>.
- [126] R. M. Santilli, A. O. E. Animalu et al., *Isoscattering theory of hadronic mechanics, I: Lie-isotopic formalism without divergencies*, Hadronic J., Vol. 31, 317–350 (2008), <http://www.santilli-foundation.org/docs/SantilliAnimalu.pdf>.
- [127] A. O. E. Animalu and R. M. Santilli, *Nonunitary-isounitary scattering theory, I: Basic Formulation without divergencies for low energy re-*

- versible scattering*, to appear, Contributed paper to the 2008 IARD Conference, Thessaloniki, Greece, submitted for publication, <http://www.santilli-foundation.org/docs/IsoscattPlusIsoFeynman.pdf>.
- [128] A. K. Aringazin and R. M. Santilli, *Rudiments of molecular and magneuclear combustions*, Preprint of the Eurasian University (2009), to be published, <http://www.santilli-foundation.org/docs/Aringazin-Santilli.pdf>.
- [129] <http://www.santilli-foundation.org/docs/Moscow-2009.ppt>.
- [130] R. M. Santilli, *Experimental verification of isoredshift with possible absence of universe expansion, big bang, dark matter and dark energy*, The Open Astronomy Journal, Vol. 3, 126–144 (2010), <http://www.santilli-foundation.org/docs/Santilli-isoredshift.pdf>.
- [131] R. M. Santilli, *Experimental confirmation of the novel “Intermediate Controlled Nuclear Fusion” without harmful radiations*, in press at New Advances in Physics (2010), <http://www.santilli-foundation.org/docs/ICNF.pdf>.
- [132] R. M. Santilli, *Non unitary Lie-isotopic scattering theory of hadronic mechanics, I: Conceptual and mathematical foundations*, in press at New Advances in Physics (2011), <http://www.santilli-foundation.org/docs/Isoscattering-I.pdf>.
- [133] R. M. Santilli, *Non unitary Lie-isotopic scattering theory of hadronic mechanics, II: Deformation-isotopies of Lie’s theory, special relativity and mechanics*, in press at New Advances in Physics (2011), <http://www.santilli-foundation.org/docs/Isoscattering-II.pdf>.
- [134] A. O. E. Animalu and R. M. Santilli, *Non unitary Lie-isotopic scattering theory of hadronic mechanics, III: Formulation of the lie-isotopic scattering theory without divergences*, in press at New Advances in Physics (2011), <http://www.santilli-foundation.org/docs/Isoscattering-III-A.pdf>.
- [135] A. O. E. Animalu and R. M. Santilli, *Non unitary Lie-isotopic scattering theory of hadronic mechanics, IV: Reversible electron-proton and electron-positron scattering*, in press at New Advances in Physics (2011), <http://www.santilli-foundation.org/docs/Isoscattering-IV.pdf>.
- [136] D. I. Blokhintsev, Phys. Lett., Vol. 12, 272 (1964).
- [137] L. B. Redei, Phys. Rev., Vol. 145, 999 (1966).

- [138] C. Borghi, C. Giori C. and A. Dall'Olio, Communications of CENUFPE, Number 8 (1969) and 25 (1971).
- [139] H. Rauch et al., Phys. Lett. A, Vol. 54, 425 (1975).
- [140] G. Badurek et al., Phys. Rev. D, Vol. 14, 1177 (1976).
- [141] H. Rauch et al., Z. Physik B, Vol. 29, 281 (1978).
- [142] D. Y. Kim, Hadronic J., Vol. 1, 1343 (1978).
- [143] H. Kaiser et al., Z. Physik A, Vol. 291, 231 (1979).
- [144] H. Rauch et al., Hadronic J., Vol. 4, 1280 (1981).
- [145] G. Eder, Hadronic J., Vol. 4, 312 (1981).
- [146] G. Eder, Hadronic J., Vol. 5, 750 (1982).
- [147] H. C. Myung, *Lie Algebras and Flexible Lie-Admissible Algebras*, Hadronic Press (1982), <http://www.santilli-foundation.org/docs/Santilli-107.pdf>.
- [148] H. B. Nielsen and I. Picek, Nucl. Phys. B, Vol. 211, 269 (1983).
- [149] S. H. Aronson et al., Phys. Rev. D, Vol. 28, 495 (1983).
- [150] M. Nishioka, *Extension of the Dirac-Myung-Santilli Delta function to field theory*, Lettere Nuovo Cimento, Vol. 39, 369–372 (1984), <http://www.santilli-foundation.org/docs/Santilli-202.pdf>.
- [151] M. Nishioka, *Some realizations of hadronic mechanics*, Hadronic J., Vol. 7, 1636–1679 (1984), <http://www.santilli-foundation.org/docs/Santilli-203.pdf>.
- [152] *Irreversibility and Nonpotentiality in Statistical Mechanics*, A. Schober (Editor), Hadronic Press (1984).
- [153] H. C. Myung, *Malcev-Admissible Algebras*, Birkhauser (1986), <http://www.santilli-foundation.org/docs/Santilli-111-A.pdf>.
- [154] N. Grossman et al., Phys. Rev. Lett., Vol. 59, 18 (1987).
- [155] J. W. Sulentic, Astrophys. J., Vol. 343, 54 (1989).
- [156] A. K. Aringazin, Hadronic J., Vol. 12, 71 (1989).
- [157] A. K. Aringazin, A. Jannussis, D. F. Lopez, M. Nishioka, and B. Veljanosky, *Santilli's Lie-Isotopic Generalization of Galilei's and Einstein's Relativities*, Kostakaris Publishers, Athens, Greece (1991), <http://www.santilli-foundation.org/docs/Santilli-108.pdf>.

- [158] R. Mignani, *Quasar redshift in iso-Minkowski space*, Physics Essays, Vol. 5, 531–535 (1992), <http://www.santilli-foundation.org/docs/Santilli-31.pdf>.
- [159] J. V. Kadeisvili, *Elements of functional isonalysis*, Algebras, Groups and Geometries, Vol. 9, 283–318 (1992), <http://www.santilli-foundation.org/docs/Santilli-126.pdf>.
- [160] J. V. Kadeisvili, *Elements of Fourier-Santilli isotransforms*, Algebras, Groups and Geometries, Vol. 9, 319–342 (1992), <http://www.santilli-foundation.org/docs/Santilli-125.pdf>.
- [161] A. Enders and G. Nimtz, J. Phys. France, Vol. 2, 1693 (1992).
- [162] C. Borghi, C. Giori C. and A. Dall'Olio, (Russian) Phys. Atomic Nuclei, Vol. 56, 205 (1993).
- [163] A. Jannussis and D. Skaltsas, *Algebraic inconsistencies of a class of equations for the description of open systems and their resolution via Lie-admissible formulation*, Ann. Fond. L. de Broglie Vol. 18, 137–154 (1993), <http://www.santilli-foundation.org/docs/Santilli-129.pdf>.
- [164] D. F. Lopez, *Problematic aspects of q-deformations and their isotopic resolution*, Hadronic Journal, Vol. 16, 429–457 (1993), <http://www.santilli-foundation.org/docs/Santilli-127.pdf>.
- [165] D. S. Sourlas and G. T. Tsagas, *Mathematical Foundations of the Lie-Santilli Theory*, Ukrainian Academy of Sciences, Naukova Dumka, Kiev (1993), <http://www.santilli-foundation.org/docs/santilli-70.pdf>.
- [166] A. Garcia et al., Phys. Rev. C, Vol. 47, 2910 (1993).
- [167] A. O. E. Animalu, Hadronic J., Vol. 16, 411 (1993).
- [168] A. O. E. Animalu, Hadronic J., Vol. 17, 349 (1994).
- [169] D. F. Lopez, *Origin and axiomatization of q-deformations*, In “Symmetry Methods in Physics”, Vol. 1, Joint Institute for Nuclear Research, Dubna, Russia, 300–311 (1994), <http://www.santilli-foundation.org/docs/Santilli-121.pdf>.
- [170] A. Elduque and H. C. Myung, *Mutations of Alternative Algebras*, Kluwer Academic Publisher (1994), <http://www.santilli-foundation.org/docs/Santilli-106-A.pdf>.
- [171] A. K. Aringazin, K. M. Aringazin, *Universality of Santilli's iso-Minkowskian geometry*, in “Frontiers of Fundamental Physics,” M.

- Barone and F. Selleri, Editors, Plenum, 153–161 (1995), <http://www.santilli-foundation.org/docs/Santilli-29.pdf>.
- [172] G. T. Tsagas and D. S. Surlas, *Isomanifolds*, Algebras, Groups and Geometries, Vol. 12, pp. 1–65 (1995).
- [173] A. P. Mills, *Possibilities for measuring the passive gravitational mass of electrons and positrons in free horizontal flight*, Hadronic J., Vol. 19, 77–96 (1996), <http://www.santilli-foundation.org/docs/Santilli-11.pdf>.
- [174] N. F. Tsagas, A. Mystakidis, G. Bakos, and L. Seftelis, Hadronic J. 19, 87 (1996).
- [175] G. Tsagas, *Studies on the classification of Lie-Santilli algebras*, Algebras, Groups and Geometries, Vol. 13, 129–148 (1996), <http://www.santilli-foundation.org/docs/Tsagas.pdf>.
- [176] J. V. Kadeisvili, *An introduction to the Lie-Santilli isotopic theory*, Mathematical Methods in Applied Sciences, Vol. 19, 1349–1395 (1996), <http://www.santilli-foundation.org/docs/Santilli-30.pdf>.
- [177] J. V. Kadeisvili, *Foundations of the Lie-Santilli isotherory*, Rendiconti Circolo Matematico Palermo Suppl., Vol. 42, 83–135 (1996), <http://www.santilli-foundation.org/docs/Santilli-37.pdf>.
- [178] F. Cardone and R. Mignani, *Metric description of hadronic interactions from Bose-Einstein correlation*, JETP, Vol. 83, 10434448 (1996).
- [179] J. V. Kadeisvili, *Santilli's Isotopies of Contemporary Algebras Geometries and Relativities*, Ukrainian Academy of Sciences, Second Edition (1997), <http://www.santilli-foundation.org/docs/Santilli-60.pdf>.
- [180] G. Nimtz and W. Heitmann, Progr. Quantum Electr., Vol. 21, 81 (1997).
- [181] M. G. Kucherenko and A. K. Aringazin, *Estimate of the polarized magnetic moment of the isoelectronium in the hydrogen molecule*, Hadronic J., Vol. 21, 895–902 (1998), <http://www.santilli-foundation.org/docs/estimate.pdf>.
- [182] J. V. Kadeisvili, *Direct universality of Lorentz-Poincaré-Santilli isosymmetry for extended-deformable particles, arbitrary speeds of light and all possible spacetimes*, in “Photons: Old Problems in Light of New Ideas,” V. V. Dvoeglazov, Editor, Nova Science, 443–474 (2000), <http://www.santilli-foundation.org/docs/Santilli-25.pdf>.
- [183] A. K. Aringazin and M. G. Kucherenko, *Exact variational solution of the restricted three-body Santilli-Shillady model of the hydrogen molecule*, Had-

- ronic J., Vol. 23, 1–56 (2000), physics/0001056, <http://www.i-b-r.org/docs/3body.pdf>.
- [184] A. K. Aringazin, *On a variational solution of the four-body Santilli-Shillady model of the hydrogen molecule*, Hadronic J., Vol. 23, 57–113 (2000), physics/0001057, <http://www.santilli-foundation.org/docs/4body.pdf>.
- [185] A. K. Aringazin and M. B. Semenov, *Isoelectronium correlations as a non-linear two-dimensional two-particles tunnel effect*, Hadronic Journal, Vol. 23, 25–53 (2000), <http://www.santilli-foundation.org/docs/tunnel.pdf>.
- [186] Raul M. Falcon Ganfornina and Juan Nunez Valdes, *Fundamentos de la Isoteoria de Lie-Santilli*, International Academic Press (2001), <http://www.i-b-r.org/docs/spanish.pdf>.
- [187] Chun-Xuan Jiang, *Foundations of Santilli's Isonumber Theory with Applications to New Cryptograms, Fermat's Theorem, and Goldbach's Conjecture* International Academic Press (2002), <http://www.i-b-r.org/docs/jiang.pdf>.
- [188] R. M. Falcón and J. Núñez, *Studies on the Tsagas-Sourlas-Santilli isotopology*, Algebras, Groups and Geometries, Vol. 20, 1–23 (2003), <http://www.santilli-foundation.org/docs/Isotopology-.pdf>.
- [189] A. A. Logunov, *Henri Poincaré and Relativity Theory*, Nauka, Moscow (2005), <http://www.santilli-foundation.org/docs/Logunov.pdf>.
- [190] J. Dunning-Davies, *Exploding a Myth*, Horwood Publishing, England (2007), <http://www.santilli-foundation.org/docs/Dunning-DaviesBook.pdf>.
- [191] R. Perez-Enriquez, J. L. Marin and R. Riera, *Exact solution of the three-body Santilli-Shillady model of the hydrogen molecule*, Progress in Physics, Vol. 2, 34–41 (2007), physics/0001056, <http://www.santilli-foundation.org/docs/3body2.pdf>.
- [192] M. O. Cloonan, *A new electronic theory of pericyclic chemistry and aromaticity is proposed: The Cplex-isoelectronic theory consistent with Santilli's hadronic chemistry*, Int. J. Hydrogen Energy, Vol. 32, 159–171 (2007), <http://www.santilli-foundation.org/docs/Cloonan-Paper1.pdf>.
- [193] M. O. Cloonan, *Application of the Cplex-isoelectronic theory to electrocyclicisations, sigmatropic rearrangements, cheletropic reactions and antiaromaticity: consistent with Santilli's hadronic chemistry*, Int. J. Hydrogen Energy, Vol. 32, 3026–3039 (2007), <http://www.santilli-foundation.org/docs/Cloonan-Paper2.pdf>.

- [194] B. Davvaz, *Hyperings Theory and Applications*, International Academic Press (2007), available as free download from <http://www.santilli-foundation.org/docs/Davvaz.pdf>.
- [195] H. E. Wilhelm, *Galilei invariant electrodynamics and quantum mechanics relative to the cosmic aether frame*, Hadronic J., Vol. 31 (2008), in press, <http://www.santilli-foundation.org/docs/Wilhelm.pdf>.
- [196] J. R. Fanchi, *Tutorial on parameterized relativistic dynamics*, Hadronic J., Vol. 31, 351–450 (2008), <http://www.santilli-foundation.org/docs/Fanchi.pdf>.
- [197] J. V. Kadeisvili, *The Rutherford-Santilli neutron*, Hadronic J., Vol. 31, 1–114 (2008), <http://www.i-b-r.org/Rutherford-Santilli-II.pdf>.
- [198] A. K. Aringazin, *Toroidal configuration of the orbit of the electron of the hydrogen atom under strong external magnetic fields*, to appear in Hadronic J., <http://www.santilli-foundation.org/docs/landau.pdf>.
- [199] J. Dunning-Davies, *Isodual thermodynamics for antimatter*, to be completed and uploaded <http://www.santilli-foundation.org/docs/Dunning-Davies.pdf>.
- [200] R. Brenna, T. Kuliczkowski and L. Ying, *Verification of Santilli's intermediate nuclear fusions without harmful radiation and the production of magnecular clusters*, Princeton Gamma-Tech Instruments, Princeton, New Jersey, in press at New Advances in Physics, <http://www.santilli-foundation.org/docs/Confirm-ICNF.pdf>.
- [201] R. Anderson, *Outline of the novel intermediate controlled nuclear fusions*, English version <http://www.santilli-foundation.org/docs/Intermediate-Nuclear-Fusions.doc>, Russian version <http://www.santilli-foundation.org/docs/Intermediate-Nuclear-Fusions.doc>, Italian version <http://www.santilli-foundation.org/docs/Intermediate-Nuclear-Fusions-ita.doc>, Turkish version <http://www.santilli-foundation.org/docs/Turkish.pdf>, French version http://fr.wikipedia.org/wiki/Chimie_hadronique.
- [202] M. Sacerdoti, *I nuovi numeri santilliani, Parte I: I nuovi numeri isotopici e loro applicazioni*, to appear, http://www.i-b-r.org/Isonumeri_Santilliani-I.pdf.
- [203] M. Sacerdoti, *I nuovi numeri santilliani, Parte II: I nuovi numeri genotopici ed iperstrutturali e loro applicazioni*, to appear, http://www.i-b-r.org/Isonumeri_Santilliani-II.pdf.

- [204] M. Sacerdoti, *I nuovi numeri santilliani, Parte III: I nuovi numeri isoduali e loro applicazioni*, to appear, http://www.i-b-r.org/Isonumeri_Santilliani-III.pdf.
- [205] W. Pound, *Recycling of nuclear waste*, <http://www.nuclearwasterecycling.com>.
- [206] *General Bibliography on Prof. R. M. Santilli Scientific Discoveries* <http://www.santilli-foundation.org/docs/Santilli-64.pdf>.
- [207] *Curriculum Vitae of Prof. Ruggero Maria Santilli* <http://www.i-b-r.org/Ruggero-Maria-Santilli.htm>.



Index

Santilli, 7





The R.M. Santilli Foundation

150 Rainville Rd, Tarpon Springs, FL 34689, USA

board@santilli-foundation.org, www.santilli-foundation.org